

TABLE OF CONTENTS

1.0	INTRODUCTION	1
1.1	SYSTEM COVERAGE	1
1.2	SIX-STEP TROUBLESHOOTING PROCEDURE	1
2.0	IDENTIFICATION OF SYSTEM	1
3.0	SYSTEM DESCRIPTION AND FUNCTIONAL OPERATION	1
3.1	AIRBAG SYSTEM	1
3.1.1	DRIVER AIRBAG	2
3.1.2	CLOCKSPRING	3
3.1.3	PASSENGER AIRBAG	3
3.1.4	SEAT BELT TENSIONERS	3
3.1.5	SPECIAL TOOLS	3
3.1.6	DIAGNOSTIC TROUBLE CODES	4
3.1.6.1	ACTIVE CODES	4
3.1.6.2	STORED CODES	4
3.2	COMMUNICATION	4
3.2.1	COMMUNICATION K-LINES	4
3.2.2	CAN BUS	5
3.3	HEATING & A/C SYSTEM	5
3.3.1	AUTOMATIC TEMPERATURE CONTROL (ATC)	5
3.3.1.1	SYSTEM CONTROLS	5
3.3.1.2	SYSTEM DIAGNOSTICS	5
3.3.2	CABIN HEATER MODULE (CHM) & HEATER BOOSTER MODULE (HBM)	7
3.3.2.1	SYSTEM DESCRIPTION	7
3.3.2.2	VENTING THE HEATER'S EXHAUST	8
3.3.2.3	SYSTEM DIAGNOSTICS	8
3.4	INSTRUMENT CLUSTER	9
3.5	POWER DOOR LOCKS/RKE	9
3.5.1	CENTRAL LOCKING	9
3.5.2	REMOTE KEYLESS ENTRY (RKE)	9
3.5.3	AUTO DOOR LOCKS	10
3.5.4	ACCIDENT RESPONSE	10
3.6	VEHICLE THEFT SECURITY SYSTEM (VTSS)	10
3.7	USING THE DRBIII®	11
3.8	DRBIII® ERROR MESSAGES	11
3.9	DRBIII® DOES NOT POWER UP (BLANK SCREEN)	11
3.10	DISPLAY IS NOT VISIBLE	11
4.0	DISCLAIMERS, SAFETY, WARNINGS	11
4.1	DISCLAIMERS	11
4.2	SAFETY	11
4.2.1	TECHNICIAN SAFETY INFORMATION	11
4.2.2	VEHICLE PREPARATION FOR TESTING	12
4.2.3	SERVICING SUB-ASSEMBLIES	12
4.2.4	DRBIII® SAFETY INFORMATION	12
4.3	WARNINGS	12
4.3.1	VEHICLE DAMAGE WARNINGS	12
4.3.2	ROAD TESTING A COMPLAINT VEHICLE	12

TABLE OF CONTENTS - Continued

5.0	REQUIRED TOOLS AND EQUIPMENT	13
6.0	GLOSSARY OF TERMS	13
7.0	DIAGNOSTIC INFORMATION AND PROCEDURES	15
	AIRBAG	
	AIRBAG WARNING INDICATOR - DRIVER HIGH	16
	AIRBAG WARNING INDICATOR - DRIVER LOW	19
	DRIVER SEAT BELT TENSIONER - INCORRECT FEEDBACK	22
	DRIVER SQUIB 1 - INCORRECT FEEDBACK	22
	INTERNAL 1	22
	INTERNAL 2	22
	INTERNAL 3	22
	PASSENGER SEAT BELT TENSIONER - INCORRECT FEEDBACK	22
	PASSENGER SQUIB 1 - INCORRECT FEEDBACK	22
	STORED ENERGY FIRING 1	22
	STORED ENERGY FIRING 2	22
	DRIVER SEAT BELT TENSIONER CIRCUIT OPEN	24
	DRIVER SEAT BELT TENSIONER CIRCUIT SHORT	26
	DRIVER SEAT BELT TENSIONER SHORT TO BATTERY	28
	DRIVER SEAT BELT TENSIONER SHORT TO GROUND	31
	DRIVER SQUIB 1 CIRCUIT OPEN	33
	DRIVER SQUIB 1 CIRCUIT SHORT	36
	DRIVER SQUIB 1 SHORT TO BATTERY	39
	DRIVER SQUIB 1 SHORT TO GROUND	42
	LOSS OF IGNITION RUN - START	45
	PASSENGER SEAT BELT TENSIONER CIRCUIT OPEN	47
	PASSENGER SEAT BELT TENSIONER CIRCUIT SHORT	49
	PASSENGER SEAT BELT TENSIONER SHORT TO BATTERY	51
	PASSENGER SEAT BELT TENSIONER SHORT TO GROUND	54
	PASSENGER SQUIB 1 CIRCUIT OPEN	56
	PASSENGER SQUIB 1 CIRCUIT SHORT	59
	PASSENGER SQUIB 1 SHORT TO BATTERY	62
	PASSENGER SQUIB 1 SHORT TO GROUND	65
	*AIRBAG WARNING INDICATOR FLASHING	68
	CABIN HEATER	
	A. HEATER PRE-TEST	69
	CIRC PUMP CONTROL OPEN	72
	CIRC PUMP CONTROL SHORTED	74
	COMBUST FAN SHORTED	76
	COMBUST FAN SPEED INCORRECT	76
	COMBUSTION FAN OPEN	76
	CONTROL UNIT FAULTY	77
	DOSING PUMP OPEN	78
	DOSING PUMP SHORTED	81
	FAN STAGE 1 RELAY CONTROL OPEN	83
	FAN STAGE 1 RELAY CONTROL SHORTED	85
	FLAME DETECT PRIOR TO COMBUST	87
	FLAME OUT	88
	NO START	88
	FLAME SENSOR OPEN	91

TABLE OF CONTENTS - Continued

FLAME SENSOR SHORTED	91
GLOW PIN OPEN	91
GLOW PIN SHORTED	91
HEATER IN LOCKOUT MODE	93
HEATER OVERHEATED	93
SUCCESSIVE OVERHEATING	93
OVER VOLTAGE	96
OVERHEATING SENSOR OPEN	97
OVERHEATING SENSOR SHORTED	97
TEMP SENSOR OPEN	98
TEMP SENSOR SHORTED	98
UNDER VOLTAGE	99

COMMUNICATION

*NO RESPONSE FROM AIRBAG CONTROL MODULE	102
*NO RESPONSE FROM AUTOMATIC TEMPERATURE CONTROL	104
*NO RESPONSE FROM CABIN HEATER MODULE	106
*NO RESPONSE FROM CENTRAL TIMER MODULE	108
*NO RESPONSE FROM CONTROLLER ANTILOCK BRAKE	110
*NO RESPONSE FROM ENGINE CONTROL MODULE	112
*NO RESPONSE FROM HEATER BOOSTER MODULE	114
*NO RESPONSE FROM INSTRUMENT CLUSTER	116
*NO RESPONSE FROM SECURITY SYSTEM MODULE	118
*NO RESPONSE FROM SENTRY KEY REMOTE ENTRY MODULE	120
*NO RESPONSE FROM SHIFTER ASSEMBLY	122
*NO RESPONSE FROM TRANSMISSION CONTROL MODULE	124

HEATING & A/C

A/C COMPRESSOR CONTROL HIGH OR OPEN (ACTIVE)	126
A/C COMPRESSOR CONTROL HIGH OR OPEN (STORED)	128
A/C COMPRESSOR CONTROL SHORTED LOW (STORED)	128
AIR OUTLET TEMP SENSOR HIGH OR OPEN (STORED)	128
AIR OUTLET TEMP SENSOR SHORTED LOW (STORED)	128
AUX FAN RELAY CONTROL HIGH OR OPEN (STORED)	128
AUX FAN RELAY CONTROL SHORTED LOW (STORED)	128
BLOWER STAGE 1 HIGH OR OPEN (STORED)	128
BLOWER STAGE 1 SHORTED LOW (STORED)	128
CABIN HEATER CONTROL HIGH OR OPEN (STORED)	128
CABIN HEATER CONTROL SHORTED LOW (STORED)	128
CIRC PUMP CONTROL HIGH OR OPEN (STORED)	128
CIRC PUMP CONTROL SHORTED LOW (STORED)	128
EVAP TEMP SENSOR HIGH OR OPEN (STORED)	128
EVAP TEMP SENSOR SHORTED LOW (STORED)	128
NO COMMUNICATION BUS (STORED)	128
NO COMMUNICATION WITH ECM (STORED)	128
NO COMMUNICATION WITH IC (STORED)	128
RECIRC AIR SOLENOID CONTROL HIGH OR OPEN (STORED)	128
RECIRC AIR SOLENOID CONTROL SHORTED LOW (STORED)	128
REFRIG PRESS SENSOR HIGH OR OPEN (STORED)	128
REFRIG PRESS SENSOR SHORTED LOW (STORED)	128
WATER CYCLE VALVE CONTROL HIGH OR OPEN (STORED)	128
WATER CYCLE VALVE CONTROL SHORTED LOW (STORED)	128
A/C COMPRESSOR CONTROL SHORTED LOW (ACTIVE)	130

TABLE OF CONTENTS - Continued

AIR OUTLET TEMP SENSOR HIGH OR OPEN (ACTIVE)	132
AIR OUTLET TEMP SENSOR SHORTED LOW (ACTIVE)	134
ATC FUNCTION TEST COOL FAILURE	136
ATC FUNCTION TEST FAILURE	136
ATC FUNCTION TEST HEAT FAILURE	136
AUX FAN RELAY CONTROL HIGH OR OPEN (ACTIVE)	138
AUX FAN RELAY CONTROL SHORTED LOW (ACTIVE)	140
BLOWER STAGE 1 HIGH OR OPEN (ACTIVE)	142
BLOWER STAGE 1 SHORTED LOW (ACTIVE)	144
CABIN HEATER CONTROL HIGH OR OPEN (ACTIVE)	146
CABIN HEATER CONTROL SHORTED LOW (ACTIVE)	148
CIRC PUMP CONTROL HIGH OR OPEN (ACTIVE)	150
CIRC PUMP CONTROL SHORTED LOW (ACTIVE)	152
EVAP TEMP SENSOR HIGH OR OPEN (ACTIVE)	154
EVAP TEMP SENSOR SHORTED LOW (ACTIVE)	156
NO COMMUNICATION BUS (ACTIVE)	158
NO COMMUNICATION WITH ECM (ACTIVE)	161
NO COMMUNICATION WITH IC (ACTIVE)	163
RECIRC AIR SOLENOID CONTROL HIGH OR OPEN (ACTIVE)	165
RECIRC AIR SOLENOID CONTROL SHORTED LOW (ACTIVE)	167
REFRIG PRESS SENSOR HIGH OR OPEN (ACTIVE)	169
REFRIG PRESS SENSOR SHORTED LOW (ACTIVE)	171
WATER CYCLE VALVE CONTROL HIGH OR OPEN (ACTIVE)	173
WATER CYCLE VALVE CONTROL SHORTED LOW (ACTIVE)	175

INSTRUMENT CLUSTER

AMBIENT TEMP SENSOR OPEN/SHORT TO BATTERY	177
AMBIENT TEMP SENSOR SHORT TO GROUND	179
FUEL LEVEL SENSOR OPEN/SHORT TO BATTERY	180
FUEL LEVEL SENSOR SHORT TO GROUND	182
INSTRUMENT CLUSTER INTERNAL FAILURE B1043	183
INSTRUMENT CLUSTER INTERNAL FAILURE B1053	184
INSTRUMENT CLUSTER OVERVOLTAGE	185
NO CAN COMMUNICATION WITH ABS	186
NO CAN COMMUNICATION WITH ECM	188
NO CAN COMMUNICATION WITH TCM	190
PREGLOW INDICATOR LAMP FAILURE	192
SRS INDICATOR LAMP FAILURE	193

POWER DOOR LOCKS/RKE

DRIVER DOOR AJAR INDICATOR DRIVER CIRCUIT SHORT TO GROUND	194
PASSENGER DOOR AJAR INDICATOR DRIVER CIRCUIT SHORT TO GROUND	196
REPLACE CONTROL MODULE	198
RKE INTERFACE CIRCUIT SHORT TO GROUND - CTM	199
RKE INTERFACE CIRCUIT SHORT TO GROUND - SKREEM	201
RKE INTERFACE CIRCUIT SHORT TO VOLTAGE - CTM	203
RKE INTERFACE CIRCUIT SHORT TO VOLTAGE - SKREEM	204
THE ACM HAS UNLOCKED THE DOORS	206
UNKNOWN TROUBLE CODE UNKNOWN DTC TYPE 2	207
*RKE INOPERATIVE	208
*RKE POOR RANGE	209

TABLE OF CONTENTS - Continued

VEHICLE THEFT/SECURITY	
DRIVER CYLINDER LOCK SWITCH CIRCUIT SHORT TO GROUND210
DRIVER CYLINDER UNLOCK SWITCH CIRCUIT SHORT TO GROUND212
FRONT DOOR JAMB SWITCH CIRCUIT SHORT TO GROUND214
INTERNAL ERROR - SSM216
TOWING INCLINATION SENSOR BEYOND LIMITS216
TOWING INCLINATION SENSOR VALUE IS INVALID216
TOWING INCLINATION SENSOR VALUE IS MISSING216
INTRUSION SENSOR 1 CIRCUIT OPEN/SHORT TO GROUND218
INTRUSION SENSOR 1 GROUND CIRCUIT OPEN220
INTRUSION SENSOR 2 CIRCUIT OPEN/SHORT TO GROUND221
INTRUSION SENSOR 2 GROUND CIRCUIT OPEN223
INTRUSION SENSOR 3 CIRCUIT OPEN/SHORT TO GROUND224
INTRUSION SENSOR 3 GROUND CIRCUIT OPEN226
REAR OR SLIDING DOOR JAMB SWITCH CIRCUIT SHORT TO GROUND227
RKE INTERFACE CIRCUIT FAILURE - SSM229
SECURITY SYSTEM INTERFACE FAILURE - SSM231
SIREN CIRCUIT OPEN/SHORTED TO GROUND233
SIREN INTERNAL FAILURE235
SIREN SIGNAL CONTROL CIRCUIT SHORT TO GROUND236
VERIFICATION TESTS	
VERIFICATION TESTS237
8.0 COMPONENT LOCATIONS241
8.1 AIRBAG SYSTEM241
8.2 AIRBAG CONTROL MODULE241
8.3 DRIVER AIRBAG SQUIB241
8.4 CLOCKSPRING242
8.5 SEAT BELT TENSIONER242
8.6 HEATING & A/C242
8.6.1 AUTOMATIC TEMPERATURE CONTROL (ATC) SYSTEM	
COMPONENTS242
8.6.2 CABIN HEATER & HEATER BOOSTER SYSTEM	
COMPONENTS243
8.6.3 AUTO TEMP CONTROL, CABIN HEATER, & HEATER BOOSTER	
FUSES & RELAYS243
8.6.4 EVAP TEMP SENSOR & AIR OUTLET TEMP SENSOR243
8.7 INSTRUMENT CLUSTER244
8.7.1 AMBIENT TEMPERATURE SENSOR244
8.8 POWER DOOR LOCKS/RKE244
8.8.1 CENTRAL TIMER MODULE244
8.8.2 SENTRY KEY REMOTE ENTRY MODULE245
8.8.3 DOOR LOCK MOTOR/AJAR SWITCH245
8.8.4 CONTACT PLATES245
8.8.5 DOOR LOCK MOTOR/AJAR SWITCH CONNECTORS246
8.9 VEHICLE THEFT SECURITY SYSTEM246
8.9.1 SECURITY SYSTEM MODULE246
8.9.2 INTRUSION SENSORS246
8.9.3 SWITCHES247
8.9.4 SIREN247

TABLE OF CONTENTS - Continued

9.0	CONNECTOR PINOUTS	.249
	AIR OUTLET TEMPERATURE SENSOR	.249
	AIRBAG CONTROL MODULE - YELLOW	.249
	AIRBAG SQUIB-DRIVER	.249
	AIRBAG SQUIB-PASSENGER - YELLOW	.249
	AMBIENT TEMPERATURE SENSOR	.250
	AUXILIARY HEATER SWITCH	.250
	BLOWER MOTOR RESISTOR BLOCK	.250
	BLOWER MOTOR-FRONT - BLACK	.250
	C200 - BLACK (DASH SIDE)	.251
	C200 - BLACK (MAIN BODY SIDE)	.251
	C205 - YELLOW (DASH SIDE)	.251
	C205 - YELLOW (MAIN BODY SIDE)	.252
	C219 - (MAIN BODY SIDE)	.252
	C219 - BLACK (CABIN SIDE)	.252
	CENTRAL TIMER MODULE C1 - PINK	.252
	CENTRAL TIMER MODULE C2 - LT.GREEN	.253
	CIRCULATION PUMP (CABIN HEATER MODULE)	.253
	CIRCULATION PUMP (REST SYSTEM)	.253
	CLOCKSPRING C2	.253
	CONTROLLER ANTILOCK BRAKE	.254
	CYLINDER LOCK SWITCH-DRIVER	.254
	DATA LINK CONNECTOR - BLACK	.254
	DOOR LOCK MOTOR/AJAR SWITCH ASSEMBLY-DRIVER C1	.254
	DOOR LOCK MOTOR/AJAR SWITCH ASSEMBLY-DRIVER C2	.255
	DOOR LOCK MOTOR/AJAR SWITCH ASSEMBLY-LEFT SLIDING C1	.255
	DOOR LOCK MOTOR/AJAR SWITCH ASSEMBLY-LEFT SLIDING C2	.255
	DOOR LOCK MOTOR/AJAR SWITCH ASSEMBLY-PASSENGER C1	.255
	DOOR LOCK MOTOR/AJAR SWITCH ASSEMBLY-PASSENGER C2	.255
	DOOR LOCK MOTOR/AJAR SWITCH ASSEMBLY-REAR C1	.256
	DOOR LOCK MOTOR/AJAR SWITCH ASSEMBLY-REAR C2	.256
	DOOR LOCK MOTOR/AJAR SWITCH ASSEMBLY-RIGHT SLIDING C1	.256
	DOOR LOCK MOTOR/AJAR SWITCH ASSEMBLY-RIGHT SLIDING C2	.256
	DOSING PUMP	.256
	ENGINE CONTROL MODULE C2 - BLACK	.257
	ENGINE CONTROL MODULE C3 - BLACK	.257
	EVAPORATOR TEMPERATURE SENSOR	.257
	FUEL LEVEL SENSOR	.258
	FUSE BLOCK NO. 1 C2	.258
	FUSES (FUSE BLOCK NO. 1)	.260
	FUSES (FUSE BLOCK NO. 2)	.260
	FUSES (FUSE BLOCK NO. 3)	.261
	FUSES (FUSE/RELAY BLOCK)	.261
	HOOD AJAR SWITCH - BLACK	.262
	INSTRUMENT CLUSTER C1	.262
	INSTRUMENT CLUSTER C2 - WHITE	.262
	INTRUSION SENSOR NO. 1 - BLACK	.263
	INTRUSION SENSOR NO. 2 - BLACK	.263
	INTRUSION SENSOR NO. 3 - BLACK	.263
	MASTER DOOR LOCK SWITCH	.263
	PANIC ALARM SWITCH - BLACK	.263
	RECIRCULATED AIR SOLENOID VALVE	.264

TABLE OF CONTENTS - Continued

REFRIGERANT PRESSURE SENSOR.....	264
A/C AUXILIARY FAN RELAY (IN RELAY BLOCK)	266
A/C AUXILIARY FAN.....	266
CIRCULATION PUMP RELAY (RELAY BLOCK).....	266
D(+) RELAY NO. 1 (RELAY BLOCK)	266
FAN STAGE 1 RELAY (RELAY BLOCK)	266
HORN RELAY - (RELAY BLOCK)	266
TURN SIGNAL/ANTI-THEFT ALARM RELAY-LEFT (RELAY BLOCK).....	266
TURN SIGNAL/ANTI-THEFT ALARM RELAY-RIGHT (RELAY BLOCK)	267
REMOTE KEYLESS ENTRY ANTENNA	268
SEAT BELT TENSIONER-DRIVER - YELLOW	268
SEAT BELT TENSIONER-PASSENGER - YELLOW.....	268
SECURITY SYSTEM MODULE C1 - BROWN	269
SECURITY SYSTEM MODULE C2 - LT.GREEN	269
SENTRY KEY REMOTE ENTRY MODULE (SKREEM)	269
SHIFTER ASSEMBLY - BLACK.....	270
SIREN - BLACK	270
TOWING/INTRUSION SENSOR ON/OFF SWITCH	270
TRANSMISSION CONTROL MODULE C1 - BLACK	270
TRANSMISSION CONTROL MODULE C2 - BLACK	271
WATER CYCLE VALVE.....	271
WINDOW DEFOGGER-LEFT REAR	271
WINDOW DEFOGGER-RIGHT REAR.....	271
10.0 SCHEMATIC DIAGRAMS.....	273
10.1 AIRBAG SYSTEM.....	273
10.2 COMMUNICATION	274
10.2.1 COMMUNICATION K-LINES	274
10.2.2 CAN BUS NETWORK.....	275
10.3 HEATING & A/C.....	276
10.3.1 AUTOMATIC TEMPERATURE CONTROL (ATC)	276
10.3.2 CABIN HEATER MODULE (CHM).....	277
10.3.3 HEATER BOOSTER MODULE (HBM).....	278
10.4 INSTRUMENT CLUSTER.....	279
10.5 POWER DOOR LOCKS/RKE.....	280
10.5.1 FRONT DOORS	280
10.5.2 SLIDING AND REAR DOORS	281
10.5.3 SWITCH AND MISCELLANEOUS CIRCUITS.....	282
10.6 VEHICLE THEFT SECURITY SYSTEM.....	283
11.0 CHARTS AND GRAPHS	285
11.1 EVAP TEMP SENSOR RESISTANCE TO TEMPERATURE SPECIFICATIONS.....	285
11.2 AIR OUTLET TEMP SENSOR RESISTANCE TO TEMPERATURE SPECIFICATIONS.....	285

NOTES

1.0 INTRODUCTION

The procedures contained in this manual include all the specifications, instructions and graphics needed to diagnose Sprinter body system problems. The diagnostics in this manual are based on the failure condition or symptom being present at the time of diagnosis.

Please follow the recommendations below when choosing your diagnostic path.

1. First make sure the DRBIII® is communicating with the appropriate modules; i.e., if the DRBIII® displays a “No Response” or a “Bus ± Signals Open” condition, you must diagnose that first.
2. Read DTC's (diagnostic trouble codes) with the DRBIII®.
3. If no DTC's are present, identify the customer complaint.
4. Once the DTC or customer complaint is identified, locate the matching test in the Table of Contents and begin to diagnose the symptom.

All component location views are in Section 8.0. All connector pinouts are in Section 9.0. All schematics are in Section 10.0. All Charts and Graphs are in Section 11.0.

An * placed before the symptom description indicates a customer complaint without a DTC.

When repairs are required, refer to the appropriate service information for the proper removal and repair procedure.

Diagnostic procedures change every year. New diagnostic systems may be added: carryover systems may be enhanced. **READ THIS MANUAL BEFORE TRYING TO DIAGNOSE A VEHICLE DIAGNOSTIC TROUBLE CODE.** It is recommended that you review the entire manual to become familiar with all the new and changed diagnostic procedures.

This book reflects many suggested changes from readers of past issues. After using this book, if you have any comments or suggestions, please fill out the form in the back of this book and mail it back to us.

1.1 SYSTEM COVERAGE

This diagnostic procedures manual covers all Sprinter vehicles.

1.2 SIX-STEP TROUBLESHOOTING PROCEDURE

Diagnosis of the body system is done in six basic steps:

- verification of complaint

- verification of any related symptoms
- symptom analysis
- problem isolation
- repair of isolated problem
- verification of proper operation

2.0 IDENTIFICATION OF SYSTEM

The vehicle systems that are part of the “body” system are:

- Airbag
- Automatic Temperature Control
- Communication
- Instrument Cluster
- Power Door Locks/RKE
- Vehicle Theft Security System (VTSS)

3.0 SYSTEM DESCRIPTION AND FUNCTIONAL OPERATION

The body system on the Sprinter consists of a combination of modules that communicate with each other using the CAN Bus (controller area network). Through the CAN Bus, information about the operation of vehicle components and circuits is relayed quickly to the appropriate modules. Since the CAN bus network is for intermodule communication only, the DRBIII® utilizes K-Lines to establish communications with each module. It is important to note the CAN bus circuits are by no means tied to the K-Lines. They are completely separate from each other. For additional information on the CAN bus and the K-Lines, refer to the Communication section of this general information.

3.1 AIRBAG SYSTEM

The Sprinter Airbag System contains the following components:

- Airbag Control Module (ACM)
- Airbag Warning Indicator (SRS)
- Driver Airbags
- Clockspring
- Passenger Airbag
- Driver Seat Belt Tensioners
- Passenger Seat Belt Tensioners

The Airbag Control Module (ACM) has five major functions: onboard diagnostics, determine the severity of impacts, squib deployment and Accident Response, K-Line communications. The ACM is secured to the floor under the Driver seat and

GENERAL INFORMATION

receives power from the Fuse Block No. 1. Whenever the ignition key is turned to the run or start position, the ACM performs a system test. The ACM cannot be repaired or adjusted.

The microprocessor in the ACM monitors the internal and external airbag system electrical circuits to determine the system readiness. When a monitored system is determined to be out of range, the ACM will set both active and stored diagnostic trouble codes (DTC). The ACM also contains an energy-storage capacitor. This capacitor stores enough electrical energy to deploy the front airbag components for two seconds following a battery disconnect or failure during an impact.

The Accelerometer in the ACM is used to sense the rate of vehicle deceleration, provide verification of the direction and severity of an impact. When the preprogrammed conditions are met, the ACM sends an electrical signal to deploy the appropriate front airbag system components and a deployment notification.

To provide an accident response notification, the ACM is hardwired to the Central Timer module (CTM) and Engine Control Module (ECM). When a deployment occurs the ACM provides a 50ms 10.0 volt pulse to the CTM and ECM. When the Accident Report notification signal is received the CTM unlocks the door locks and the ECM stalls the engine. The Accident signal will set a DTC in the CTM and the door locks will not work until the DTC has been erased. The ECM will set a DTC if the Accident Report circuit is shorted to battery voltage. The ACM saves the deployment record and after three deployments the ACM must be replaced. The DRBIII® can be used to test the Accident Report Notification feature: select the SYSTEM TEST from the ACM main menu. Then select the Analog Crash Output System Test.

The ACM is hardwired to the Instrument Cluster (MIC) to control Warning Indicator (SRS indicator). When DTCs become activate, the ACM illuminates the Warning Indicator by pulling the indicator circuit low. The SRS indicator is the only point at which the customer can observe symptoms of a system malfunction.

As part of the system test the ACM illuminates the Warning Indicator on for 4.0 second bulb test. After the lamp check, if the indicator turns off, it means that the ACM has checked the system and found it to be free of discernible malfunctions.

NON-CRITICAL DTCs

If the lamp comes on and stays on for a period longer than 4.0 seconds (about 10.0 seconds) is usually a stored DTC (intermittent problem) in the system.

CRITICAL DTCs

DTCs that could lead to a condition where the safety devices may not deploy or incorrectly deploy. In the event of such a DTC, the safety of the vehicle occupants can no longer be guaranteed. If the lamp remains on, there could be an active DTC in the system. Some DTCs, Internal Module and squib DTCs, will keep the indicator illuminated even if the codes are no longer active.

ACM NOT CONFIGURED FOR PASSENGER AIRBAG AND TENSIONER

If after replacing the ACM the Airbag Warning Indicator flashes continuously the ACM must be configured for the Passenger Airbag and Tensioner. Select Miscellaneous from the ACM main menu and configure the Passenger Airbag Tensioner squibs.

WARNING: THE AIRBAG SYSTEM IS A SENSITIVE, COMPLEX ELECTROMECHANICAL UNIT. BEFORE ATTEMPTING TO DIAGNOSE OR SERVICE ANY AIRBAG SYSTEM OR RELATED STEERING WHEEL, STEERING COLUMN, OR INSTRUMENT PANEL COMPONENTS YOU MUST FIRST DISCONNECT AND ISOLATE THE BATTERY NEGATIVE (GROUND) CABLE. WAIT TWO MINUTES FOR THE SYSTEM CAPACITOR TO DISCHARGE BEFORE FURTHER SYSTEM SERVICE. THIS IS THE ONLY SURE WAY TO DISABLE THE AIRBAG SYSTEM. FAILURE TO DO THIS COULD RESULT IN ACCIDENTAL AIRBAG DEPLOYMENT AND POSSIBLE PERSONAL INJURY.

WARNING: TO AVOID PERSONAL INJURY OR DEATH, NEVER STRIKE OR KICK THE AIRBAG CONTROL MODULE, AS IT CAN DAMAGE THE IMPACT SENSOR OR AFFECT ITS CALIBRATION.

WARNING: IF AN AIRBAG CONTROL MODULE IS ACCIDENTALLY DROPPED DURING SERVICE, THE MODULE MUST BE SCRAPPED AND REPLACED WITH A NEW UNIT. FAILURE TO TAKE THE PROPER PRECAUTIONS COULD RESULT IN ACCIDENTAL AIRBAG DEPLOYMENT AND PERSONAL INJURY OR DEATH.

3.1.1 DRIVER AIRBAG

The airbag protective trim cover is the most visible part of the driver side airbag system. The airbag is mounted directly to the steering wheel. Located under the trim cover are the airbag cushion and the airbag cushion supporting components.

When supplied with the proper electrical signal, the inflator discharged the gas directly into the cushion. The airbag cannot be repaired, and must be replaced if deployed or in any way damaged.

WARNING: THE DRIVER AIRBAG MODULE CONTAINS ARGON GAS PRESSURIZED TO OVER 17236.89 Kpa (2500 PSI). DO NOT ATTEMPT TO DISMANTLE AN AIRBAG MODULE OR TAMPER WITH ITS INFLATOR. DO NOT PUNCTURE, INCINERATE, OR BRING INTO CONTACT WITH ELECTRICITY. DO NOT STORE AT TEMPERATURE EXCEEDING 93°C (200°F). REPLACE AIRBAG SYSTEM COMPONENTS ONLY WITH PARTS SPECIFIED IN THE CHRYSLER MOPAR PARTS CATALOG. SUBSTITUTE PARTS MAY APPEAR INTER-CHANGEABLE, BUT INTERNAL DIFFERENCES MAY RESULT IN INFERIOR OCCUPANT PROTECTION. THE FASTENERS, SCREWS, AND BOLTS ORIGINALLY USED FOR THE AIRBAG SYSTEM COMPONENTS HAVE SPECIAL COATINGS AND ARE SPECIFICALLY DESIGNED FOR THE AIRBAG SYSTEM. THEY MUST NEVER BE REPLACED WITH ANY SUBSTITUTES. ANY TIME A NEW FASTENER IS NEEDED, REPLACE IT WITH THE CORRECT FASTENERS PROVIDED IN THE SERVICE PACKAGE OR SPECIFIED IN THE MOPAR PARTS CATALOG. FAILURE TO TAKE THE PROPER PRECAUTIONS COULD RESULT IN ACCIDENTAL AIRBAG DEPLOYMENT AND PERSONAL INJURY OR DEATH.

3.1.2 CLOCKSPRING

The clockspring is mounted on the steering column under the steering wheel. This assembly consists of a plastic housing which contains a flat, ribbon-like, electrically conductive tape that winds and unwinds with the steering wheel rotation. The clockspring is used to maintain a continuous electrical circuit between the instrument panel wiring and the driver airbag and the horn. The clockspring must be properly centered when it is reinstalled on the steering column following any service procedure, or it could be damaged. The clockspring cannot be repaired and it must be replaced.

3.1.3 PASSENGER AIRBAG

The Passenger Airbag is optional equipment. When supplied with the proper electrical signal the passenger airbag inflator discharges the gas di-

rectly into the cushion. The airbag module cannot be repaired, and must be replaced if deployed or in any way damaged.

WARNING: THE PASSENGER AIRBAG MODULE CONTAINS ARGON GAS PRESSURIZED TO 17236.89 Kpa (2500 PSI). DO NOT ATTEMPT TO DISMANTLE AN AIRBAG MODULE OR TAMPER WITH ITS INFLATOR. DO NOT PUNCTURE, INCINERATE, OR BRING INTO CONTACT WITH ELECTRICITY. DO NOT STORE AT TEMPERATURE EXCEEDING 93°C (200°F). REPLACE AIRBAG SYSTEM COMPONENTS ONLY WITH PARTS SPECIFIED IN THE MOPAR PARTS CATALOG. SUBSTITUTE PARTS MAY APPEAR INTER-CHANGEABLE, BUT INTERNAL DIFFERENCES MAY RESULT IN INFERIOR OCCUPANT PROTECTION. THE FASTENERS, SCREWS, AND BOLTS ORIGINALLY USED FOR THE AIRBAG SYSTEM COMPONENTS HAVE SPECIAL COATINGS AND ARE SPECIFICALLY DESIGNED FOR THE AIRBAG SYSTEM. THEY MUST NEVER BE REPLACED WITH ANY SUBSTITUTES. ANY TIME A NEW FASTENER IS NEEDED, REPLACE IT WITH THE CORRECT FASTENERS PROVIDED IN THE SERVICE PACKAGE OR SPECIFIED IN THE MOPAR PARTS CATALOG. FAILURE TO TAKE THE PROPER PRECAUTIONS COULD RESULT IN ACCIDENTAL AIRBAG DEPLOYMENT AND PERSONAL INJURY OR DEATH.

3.1.4 SEAT BELT TENSIONERS

Front seat belt systems incorporate a Driver and optional Passenger Seat Belt Tensioner Retractors. At the onset of an impact event each tensioner uses a pyrotechnic device, which is triggered simultaneously with the front airbags, to rapidly retract the seat belts. With the slack removed, the occupant's forward motion in an impact will be reduced as will the likelihood of contacting interior components. After an impact that deploys the airbag, the seat belt tensioner assembly must be replaced. The ACM module monitors the Seat Belt Tensioners circuit resistance and reports active and stored DTCs if any problem is found. Follow all of the safety procedures when servicing tensioner.

3.1.5 SPECIAL TOOLS

Airbag load tools 8310 and 8443 are used in some airbag diagnostic test. The load tools contain fixed resistive loads, jumpers and adapters. The fixed

GENERAL INFORMATION

loads are connected to cables and mounted in a storage case. The cables can be directly connected to some airbag system connectors. Jumpers are used to convert the load tool cable connectors to the other airbag system connectors. The adapters are connected to the module harness connector to open shorting clips and protect the connector terminal during testing. When using the load tool follow all of the safety procedures in the service information for disconnecting airbag system components. Inspect the wiring, connector and terminals for damage or misalignment. Substitute the airbag load tool in place of a Driver or Passenger Airbag, seat belt tensioner, clockspring (use a jumper if needed). Then follow all of the safety procedures in the service information for connecting airbag system components. Read the module active DTCs. If the module reports NO ACTIVE DTCs the defective components has been removed from the system and should be replaced. If the DTC is still active, continue this process until all components in the circuit have been tested. Then disconnect the module connector and connect the matching adapter to the module connector. With all airbags disconnected and the adapter installed the squib wiring can be tested for open and shorted conditions.

3.1.6 DIAGNOSTIC TROUBLE CODES

Airbag diagnostic trouble codes consist of active and stored codes. If more than one code exists, diagnostic priority should be given to the active codes. Each diagnostic trouble code is diagnosed by following a specific testing procedure. The diagnostic test procedures contain step-by-step instructions for determining the cause of the trouble codes. It is not necessary to perform all of the tests in this book to diagnose an individual code. Always begin by reading the diagnostic trouble codes with the DRBIII®. This will direct you to the specific test(s) that must be performed. In certain test procedures within this manual, diagnostic trouble codes are used as a diagnostic tool.

3.1.6.1 ACTIVE CODES

If the lamp remains on, there could be an active DTC in the system. The code becomes active as soon as the malfunction is detected or key-on, whichever occurs first. An active trouble code indicates an on-going malfunction. This means that the defect is currently there every time the airbag control module checks that circuit or component. Some DTCs, Internal Module and squib DTCs, will keep the indicator illuminated even if they are no longer active. If the lamp is on and no active codes are present, cycling the ignition switch off and then on will refresh the lamp state. It is impossible to erase an active code.

3.1.6.2 STORED CODES

Airbag codes are automatically stored in the ACM's memory as soon as the malfunction is detected. A stored code indicates there was an active code present at some time. Stored diagnostic trouble code will remain stored until erased by the DRB. If a malfunction is not active while performing a diagnostic test procedure, the active code diagnostic test will not locate the source of the problem. In this case, the stored code can indicate an area to inspect. Maintain a safe distance from all airbags while performing the following inspection. If no obvious problems are found, erase stored codes, and with the ignition on wiggle the wire harness and connectors, rotate the steering wheel from stop to stop. Recheck for codes periodically as you work through the system. This procedure may uncover a malfunction that is difficult to locate.

3.2 COMMUNICATION

3.2.1 COMMUNICATION K-LINES

The K-Lines are a group of circuits that connect each control module to the Data Link Connector (DLC). Each control module is connected to the DLC with a single K-Line. The DRBIII® uses the K-Line to communicate with each control module. With the use of the K-Lines the DRBIII® is able to read each control modules DTCs, sensor displays, I/Os etc. If DRBIII® communications with a particular control module is lost, one of the possible causes could be a fault in the module's K-Line.

NOTE: It is important to note the DRBIII® uses the K-Lines for diagnostic and monitoring functions and is no way connected to the CAN data bus network.

The following modules that use the K-line on this vehicle are:

- Airbag Control Module (ACM)
- Automatic Temperature Control (ATC)
- Cabin Heater Module (CHM)
- Central Timer Module (CTM)
- Controller Antilock Brake (CAB)
- Engine Control Module (ECM)
- Heater Booster Module (HBM)
- Instrument Cluster (IC)
- Shifter Assembly (SA)
- Security System Module (SSM)
- Sentry Key Remote Entry Module (SKREEM)
- Transmission Control Module (TCM)

3.2.2 CAN BUS

The CAN bus (controller area network) is a data bus system specifically design for inter module communication on this vehicle. The CAN bus consists of a special twisted two-core cable. Control modules are connected to this "twisted pair". The CAN bus incorporates two terminating resistors. One terminator is built into the Engine Control Module (ECM) and the other is built into the Sentry Key Remote Entry Module (SKREEM). Each resistor has a value of 120 ohms. The resistor condition can be confirmed by disconnecting the control module and measuring the resistance value at the appropriate control module pins. This measurement should read 120 ohms. The two CAN circuits, CAN C Bus (+) and CAN C Bus (-), are bridged by these two terminating resistors when all control modules are connected to the bus. These two resistors are connected to the CAN bus network in parallel. The measurement between the two twisted CAN circuits, with both the ECM and SKREEM connected, should measure a value of 60 ohms.

The CAN bus is bi-directional. This means that each connected control module can send and receive information. Transmission of data takes place redundantly via both circuits. The data bus levels are mirrored, meaning that if the binary level on one circuit is 0, the other circuit transmits binary level 1 and vice versa. The two line concept is used for two reasons: for fault identification and as a safety concept.

If a voltage peak occurs on just one circuit, the receivers can identify this as a fault and ignore the voltage peak. If a short circuit or interruption occurs on one of the two CAN circuits, a software-hardware linked safety concept allows switching to a single-line operation. The defective CAN circuit is shut down. A specific data protocol controls how and when the participants can send and receive.

NOTE: It is important to note the CAN Bus circuits are used for inter-module communication only, and is no way connected to the K-Lines.

The following modules that use the CAN Bus on this vehicle are:

- Automatic Temperature Control (ATC)
- Controllor Antilock Brake (CAB)
- Engine Control Module (ECM)
- Instrument Cluster (IC)
- Sentry Key Remote Entry Module (SKREEM)
- Shifter Assembly (SA)
- Transmission Control Module (TCM)

3.3 HEATING & A/C SYSTEM

3.3.1 AUTOMATIC TEMPERATURE CONTROL (ATC)

3.3.1.1 SYSTEM CONTROLS

The ATC Module:

- is fully addressable with the DRBIII®.
 - The DRBIII® communicates with the ATC Module through the Diagnostic Link Connector (DLC) via a K-Line.
- communicates with other modules over the Controller Area Network (CAN) C Bus.
- controls A/C clutch operation.
- controls EBL operation.
- controls water cycle valve operation.
 - The water cycle valve is a normally open valve, meaning that it allows full engine coolant flow through the heater core when no power is delivered to the valve. The ATC controls the valve with a pulse width signal. The lower the percentage of the pulse width signal the more the valve is open.
- controls Residual Heat Utilization (REST) function.
- controls blower motor operation, providing four blower speeds (Low, M1, M2, & High).
- controls recirculation air solenoid valve.
- controls the mode door via cables.
- controls the main power supply to the Heater Booster (if equipped).
- uses air inlet temperature sensor, air outlet temperature sensor, and evaporator temperature sensor input, as well as data from other modules to maintain occupant comfort levels.

3.3.1.2 SYSTEM DIAGNOSTICS

Fault detection is through active and stored Diagnostic Trouble Codes (DTCs)

- DTCs are displayed by the DRBIII®.
- Active DTCs are those which currently exist in the system. The condition causing the fault must be repaired in order to clear this type of DTC.
- Stored DTCs are those which occurred in the system since the ATC Module received the last "clear diagnostic info" message.

Testing Preparation & Diagnostics

Set the necessary system functions accordingly so that all of the following prerequisites are met prior to performing diagnostic tests on the ATC system:

GENERAL INFORMATION

1. Connect the DRBIII® to the DLC.
2. Place the shift lever in park.
3. Start the engine.
4. Set the blower to high speed.
5. Set the temperature selector to full cold.
6. Press air conditioning switch on.
7. With the DRBIII® in Sensors, verify that the:
 - A. ambient temperature is above 59F (15C).
 - B. refrigerant pressure is between 29 and 348 PSI (2 and 24 bar).
 - C. evaporator temperature is above 36.5F (2.5C).
 - D. coolant temperature is above 158F (70C).

When all of the prerequisites have been met, use the DRBIII® to record and erase all stored ATC DTCs, and then select System Tests, and run the ATC Function Test. When complete, check to see if any active DTCs are present. If so, refer to the symptom list in the Heating & A/C category for the diagnostic procedure(s). If there are no DTCs present, yet the performance seems less than ideal, use the DRBIII® to look at all sensor values and the status of the various inputs and outputs to see if there is a deficiency detected that has not fully shut down the system. For additional information, refer to Sensor Values and Input/Output Status under Diagnostic Tips in this section and to Section 11.0 for evaporator temperature sensor and air outlet temperature sensor resistance to temperature specifications charts. Also, confirm that the water cycle valve is functioning. Remember that the valve is normally open. The pulse width signal will offer insight into the valve's operation. The lower the percentage number, the more open the valve becomes. Confirm that the valve is responding to the signal from the ATC. If functioning correctly, verify mode and blend door operation. If okay, the diagnosis then becomes purely refrigerant system related. Attach the appropriate gauges and diagnose the refrigeration system. Refer to the Service Information for refrigerant system diagnostic procedures.

DIAGNOSTIC TIPS

SENSOR VALUES

Ambient Air Temperature

The Instrument Cluster transmits Ambient Air Temperature Sensor data. In the event of a CAN Bus communication failure, the last stored value is displayed as a substitute value.

Interior Temperature

The normal range for the Interior Temperature Sensor is from 32°F to 104°F. An implausible temperature value indicates that the Interior Temperature Sensor is bad. The repair in this case would be to replace the ATC Module since the sensor is integral to the module.

Evaporator Temperature

The normal range for the Evaporator Temperature Sensor is from 14°F to 104°F. A substitute value of 14°F with no updates indicates an Evaporator Temperature Sensor circuit failure.

Air Outlet Temperature

The normal range for the Air Outlet Temperature Sensor is from 32°F to 203°F. A substitute value of 111.1°F indicates an Air Outlet Temperature Sensor circuit failure.

Coolant Temperature

The Engine Control Module transmits Coolant Temperature Sensor data. In the event of a CAN Bus communication failure, 257°F is displayed as a substitute value.

Interior Temperature Controller

The normal range for the Blend control is from 62°F to 144°F. This value represents the temperature set by the operator. An implausible temperature value or a temperature value that fails to change when rotating the Blend control indicates that the Blend control is bad. The repair in this case would be to replace the ATC Module since the Blend control integral to the module.

Refrigerant Pressure

The normal range for the Refrigerant Pressure Sensor is from 29 PSI to 406 PSI. A substitute value of 413 PSI indicates a Refrigerant Pressure Sensor circuit failure. In addition, the normal range for Pressure Sensor voltage is 0 volts to 5 volts. A value of 0.9 volts indicates an open voltage supply circuit, while a value of -999 indicates an open in all three sensor circuits.

Water Cycle Valve

The normal range of the Water Cycle Valve is from 0% to 100%. The value indicates the extent to which the valve is closed. A value of 100% indicates that the valve is fully closed.

Intense Inst Light

The Instrument Cluster transmits this data. The normal range for lighting intensity is from 0% to 100%. The value indicates the extent to which the illumination has dimmed. A value of 0% indicates bright while a value >0% indicates dimming. In the event of a CAN Bus communication failure, 0% is displayed as a substitute value.

INPUT/OUTPUT STATUS

Compressor Clutch

The ATC Module transmits this data. A status of "ON" indicates that the compressor is operational. A status of "OFF" indicates the compressor is not operational.

Compres SO Accel (Compressor Shut Off - Due To Acceleration)

The Engine Control Module transmits this data. A status of "YES" indicates that the compressor shut off because of an acceleration request. A status of "NO" indicates that there is no acceleration request. If shut off due to an acceleration request, the compress will switch on again after 20 seconds. In addition, the original acceleration request can no longer exist for the ECM to acknowledge a subsequent request. In the event of a CAN Bus communication failure, "NO" is displayed as a substitute value.

Compres SO W/E-Off (Compressor Shut Off - Due to Emergency Off)

The Engine Control Module transmits this data. A status of "YES" indicates that the compressor shut off because of an emergency off request. A status of "NO" indicates that there is no emergency off request. In the event of a CAN Bus communication failure, the last stored value is displayed as a substitute value.

Auxiliary Fan

The ATC Module transmits this data. A status of "ON" indicates that the auxiliary fan is operational. A status of "OFF" indicates that the auxiliary fan is not operational. The Auxiliary Fan normally operates when refrigerant head pressure exceeds 290 PSI and coolant temperature exceeds 221°F. In the event of a CAN Bus communication failure, 257°F is displayed for coolant temperature (in Sensors) and the Auxiliary Fan will run continuously.

Light PB CTRL Module

This input displays a status of "Bright" for positive dimmer switch operation and "Dimmed" for negative dimmer switch operation. In the event of a CAN Bus communication failure, "Bright" is displayed.

3.3.2 CABIN HEATER MODULE (CHM) & HEATER BOOSTER MODULE (HBM)

3.3.2.1 SYSTEM DESCRIPTION

WARNING: NEVER OPERATE THE HEATER IN AN ENCLOSED AREA THAT DOES NOT HAVE EXHAUST VENTILATION FACILITIES. ALWAYS VENT THE HEATER'S EXHAUST WHEN OPERATING THE HEATER. REFER TO "VENTING THE HEATER'S EXHAUST" BELOW FOR PROPER EXHAUST VENTING INSTRUCTIONS. FAILURE TO FOLLOW THESE INSTRUCTIONS CAN RESULT IN PERSONAL INJURY OR DEATH.

WARNING: ALLOW THE HEATER ASSEMBLY TO COOL BEFORE PERFORMING A COMPONENT INSPECTION/REPAIR/REPLACEMENT. FAILURE TO FOLLOW THESE INSTRUCTIONS CAN RESULT IN PERSONAL INJURY OR DEATH.

WARNING: ALWAYS DISCONNECT THE VEHICLE'S BATTERY PRIOR TO PERFORMING ANY TYPE OF WORK ON THE HEATER ASSEMBLY. FAILURE TO FOLLOW THESE INSTRUCTIONS CAN RESULT IN PERSONAL INJURY OR DEATH.

WARNING: NEVER ATTEMPT TO REPAIR THE HEATER ASSEMBLY OR ANY OF ITS INTERNAL COMPONENTS. ALWAYS PERFORM HEATER COMPONENT REPLACEMENT IN ACCORDANCE WITH THE SERVICE INFORMATION. FAILURE TO FOLLOW THESE INSTRUCTIONS CAN RESULT IN PERSONAL INJURY OR DEATH.

CAUTION: Always Perform The Heater Pre-Test (In The Diagnostic Procedures) Prior To Performing Any Other Test On The Heater For The Test Result To Be Valid.

NOTE: Do not disconnect the vehicle's battery or the heater's main power-supply while the heater is in operation or in run-down mode. Failure to follow these instructions may result in excess emissions from the heater.

NOTE: Failure to prime the Dosing Pump after draining the fuel line will prevent heater activation during the first attempt to start the unit. This may also set a Diagnostic Trouble Code (DTC) in the control unit's memory. Do not perform the Dosing Pump Priming Procedure if an attempt was made to start the heater without priming the Dosing Pump first. This will put excess fuel in the heater module and cause smoke to emit from the heater's exhaust pipe when heater activation occurs.

NOTE: Waxed fuel can obstruct the fuel line and reduce flow. Check for the appropriate winter grade fuel and replace as necessary.

The Cabin Heater Assembly and Heater Booster Assembly are supplemental type heaters designed to pre-heat the engine's coolant in order to supply the vehicle's occupants with heat prior to the engine

GENERAL INFORMATION

reaching operating temperature. The heater's control unit controls and monitors combustion operation through various inputs and outputs that are contained inside the heater assembly. The supplemental heater connects to the vehicle's heater hoses and uses a separate fuel supply line and fuel pump that connects to the vehicle's fuel tank. Unlike the Heater Booster, the Cabin Heater Assembly has an integral coolant pump which allows heater operation without the vehicle's engine running. In addition, a programmable timer module can also be added to this system. Neither the Cabin Heater Assembly nor the Heater Booster Assembly are connected to the CAN Bus. Communication between the heater's control unit and the DRBIII® occurs through the Diagnostic Link Connector (DLC) via a K-Line.

3.3.2.2 VENTING THE HEATER'S EXHAUST

WARNING: NEVER OPERATE THE HEATER IN AN ENCLOSED AREA THAT DOES NOT HAVE EXHAUST VENTILATION FACILITIES. ALWAYS VENT THE HEATER'S EXHAUST WHEN OPERATING THE HEATER. FAILURE TO FOLLOW THESE INSTRUCTIONS CAN RESULT IN PERSONAL INJURY OR DEATH.

WARNING: ALLOW THE HEATER ASSEMBLY TO COOL BEFORE PERFORMING A COMPONENT INSPECTION/REPAIR/REPLACEMENT. FAILURE TO FOLLOW THESE INSTRUCTIONS CAN RESULT IN PERSONAL INJURY OR DEATH.

CAUTION: When using a powered exhaust ventilation system, do not attach the exhaust ventilation hose directly to the heater's exhaust pipe. Too much suction can prevent heater operation.

When using a powered exhaust ventilation system, affix the ventilation hose to the heater's exhaust pipe or to the vehicle in such a manor that the end of the ventilation hose remains approximately three inches away from the end of the heater's exhaust pipe.

When using a non-powered exhaust ventilation system, affix the ventilation hose directly to the heater's exhaust pipe.

3.3.2.3 SYSTEM DIAGNOSTICS

CAUTION: Always Perform The Heater Pre-Test (In The Diagnostic Procedures) Prior To Performing Any Other Test For The Test Result To Be Valid.

Fault detection is through stored Diagnostic Trouble Codes (DTCs). DTCs are displayed by the DRBIII®. The heater's control unit will store up to five DTCs in its memory. If the control unit detects a new fault in the system, one that is not already stored in its memory, it will clear the oldest of the five stored DTCs, and it will store the new fault's DTC. If the control unit detects a reoccurrence of a stored fault, it will overwrite that fault's DTC with the most recent occurrence.

DIAGNOSTIC TIPS

SENSOR VALUES

Operating Voltage

The normal range for the Operating Voltage is from 10 volts to 15 volts. The value indicates the voltage at the heater's Fused B+ terminal.

Heating Capacity

The normal range for the heating capacity is from 0% to 100%. The value indicates the momentary output of the auxiliary heater in % of the maximum output.

Coolant Temperature

The value indicates the current coolant temperature.

Flame Sensor Resistance

The normal range for the Flame Sensor is from 750 ohms to 2270 ohms. The value indicates the momentary resistance of the Flame Sensor.

INPUT/OUTPUT STATUS

Dosing Pump

A status of "ON" indicates that the Dosing Pump is operational. A status of "OFF" indicates the Dosing Pump is not operational.

Glow Pin

A status of "ON" indicates that the Glow Pin is energized. A status of "OFF" indicates the Glow Pin is not energized.

Combustion Fan

A status of "ON" indicates that the Combustion Fan is operational. A status of "OFF" indicates the Combustion Fan is not operational.

Circulation Pump

A status of "ON" indicates that the Circulation Pump is operational. A status of "OFF" indicates the Circulation Pump is not operational.

Front End Blower

A status of "ON" indicates that the Blower Motor is operational. A status of "OFF" indicates the Blower Motor is not operational.

Static Heater Signal

A status of "ON" indicates that the heater module sees the "Stationary Heating Mode ON" signal after switching on the heater with the heater timer or the auxiliary heater switch. A status of "OFF" indicates that the "Stationary Heating Mode ON" signal is not present at the heater module.

Heater Booster Mode Signal

A status of "ON" indicates that the heater module sees the "Heater Booster Mode ON" signal after switching on the heater with the auxiliary heater switch. A status of "OFF" indicates that the "Heater Booster Mode ON" signal is not present at the heater module.

3.4 INSTRUMENT CLUSTER

The Instrument Cluster has easy-to-read instruments, is capable of CAN bus communication and provides a diagnostic function. The Instrument Cluster with analog speedometer, tachometer, fuel and coolant temperature gauges comes in two versions.

- Speedometer with outer miles-per-hour (mph) scale and inner kilometers-per-hour (km/h) scale. Coolant temperature is indicated in Fahrenheit (for US).
- Speedometer with outer kilometers-per-hour (km/h) scale and inner miles-per-hours (mph) scale. Coolant temperature is indicated in degrees Celsius (for Canada).

Below the speedometer, there is a LCD multi-function indicator in clear view of the driver. Warning and indicator lights (based on colored light emitting diodes) are located in the bottom of the instrument cluster with the exception of the turn signal indicator lights, ASR warning light and reserve fuel warning light. The warning lights for the seat belt usage and parking brake/brake fluid level are located in the line above the bottom line. The indicator that illuminates up when the parking brake is applied or the brake fluid level is low is different for U.S. and Canada.

When the key is turned to the 2nd position in the ignition, the function of the following indicator lights is checked automatically: High Beam ON, Preheating, airbag malfunction. In case of a broken LED of the airbag malfunction light, the seat belt usage warning light will flash for 6 seconds after the function check is finished. The Instrument Cluster is operated with the help of 4 buttons located below the multifunction indicator. The back-lighting for the instrument cluster uses yellow LED's and can be adjusted electronically to daylight and darkness.

The instrument cluster includes a warning buzzer, which sounds (in addition to a warning light in some cases) when:

- The headlights are on with the ignition off and the door opened.
- The driver's seat belt is not fastened with the ignition on.
- The key is in the ignition and the door is open.
- Critical ASSYST information is displayed in the multifunction indicator.

3.5 POWER DOOR LOCKS/RKE

3.5.1. CENTRAL LOCKING

The Central Locking System locks all vehicle doors if any door is locked from the inside or mechanically locked with the key from the outside. However, unlocking any door, in that manner, will only unlock that particular door. The Master Door Lock Switch on the dash enables the operator to lock/unlock all doors. By pressing the top of the rocker type switch once, all doors will lock. Pressing the switch again will unlock all doors. Pressing the lower part of the switch once will lock all doors except the driver door. Pressing the lower part again will unlock all doors except the driver door. If the Central Locking System automatically unlocks after the vehicle was attempted to be locked, at least one door is not properly closed.

There are two LED indicators in the Master Door Lock Switch. The left indicator is for the driver door and the right indicator is for all passenger/cargo doors. These will indicate if a door is ajar or if the doors are locked. The door ajar switches are part of the door lock motor and are mounted in the door latch assembly.

Inside each door lock motor there is a command switch. The command switch is operated by the plunger and signals any change in the lock status, locked or unlocked. Each command switch is wired to the Central Timer Module (CTM) sometimes referred to as the Central Locking Module. If all doors are closed and are unlocked, and any door is locked by the key or the interior handle, thereby changing the command switch, all doors will be locked. If one of the door lock motors does not reach the end position after a locking command, it will be detected by the CTM (command switch not in "Locked" position) and the vehicle will be unlocked.

3.5.2 REMOTE KEYLESS ENTRY (RKE)

The SKREEM is a combination of the Remote Keyless Entry Module and the SKIM (Sentry Key Immobilizer Module). It is located behind the Instrument Cluster and has an antenna that goes up

GENERAL INFORMATION

the A-pillar. The SKREEM receives radio messages from the RKE transmitter (fob) and sends commands via the RKE Interface circuit to the CTM. If the vehicle is equipped with VTSS, the Security System Module will be connected in series between the SKREEM and the CTM.

Confirmation of the RKE Lock/Unlock state is accomplished via the turn signals. When the vehicle is locked via RKE the turn signals will flash three times. When it is unlocked via RKE, the turn signals will flash one time. If the vehicle has been unlocked via RKE and no door is opened within 40 seconds, the entire vehicle will be locked again automatically.

If a transmitter (fob) is operated more than 255 times in succession beyond the range of the receiver (SKREEM), the RKE portion of the key will become inoperative. In order to put it back in synchronization it will be necessary to have ALL the other transmitters that are used with this vehicle available and follow the following procedure:

1. Cycle the ignition on and off 2 times within 6 seconds (leave in off position).
2. Press the lock or unlock button of the disabled transmitter within 3 seconds of turning the ignition off.
3. Press any button (lock or unlock) 3 more times within 6 seconds.
4. Wait 10 seconds.
5. Press any button of ALL other transmitters belonging to this vehicle at least once within the next 20 seconds.

For problems related to the Immobilizer function of the SKREEM, see Service Information.

3.5.3 AUTO DOOR LOCKS

Whenever the engine is started, the CTM receives a message to lock all doors except the drivers door. This is accomplished through the D+ Relay. The D+ Relay is controlled by the Instrument Cluster which receives a command from the ECM that the engine is running. This relay supplies power to the CTM (for auto locking), the daytime running lamps and the rear window defogger.

3.5.4 ACCIDENT RESPONSE

The CTM is hardwired to the Airbag Control Module through the Enhanced Accident Report Driver circuit. Anytime the vehicle airbags are deployed, the CTM will unlock all doors and a "Crash" DTC will be stored in memory. The door locks will be inoperative until that code is cleared. If the vehicle is severely jarred, but not enough to deploy the airbags, it is possible that the DTC could be set and therefore the door locks would be inoperable. Whenever the door locks are not opera-

tional, use the DRBIII and check DTC's . If the code "ACM has unlocked the doors" appears, use the DRBIII and erase it.

3.6 VEHICLE THEFT SECURITY SYSTEM (VTSS)

The Security System Module (SSM) is located under the driver's seat. The SSM communicates with the DRBIII over the K-line. If equipped the Vehicle Theft Security System will monitor the following:

- door jamb switches
- hood ajar switch
- ignition switch
- interior of the vehicle for movement
- longitudinal and transverse movement of the vehicle
- rear defogger grids for glass breakage
- trailer connector

To arm the system the hood and all of the doors must be closed when the vehicle is locked with the RKE transmitter or with the use of the key in the driver door. If the key is used, it must be held in the lock position for 2 seconds. When the system is first activated, the hazard lamps will flash 3 times. Also with the system armed, the Towing/Intrusion Sensor On/Off Switch indicator will flash to indicate an armed system. To disarm the system use the RKE or the driver door lock cylinder. Unlocking and opening one of the other doors with the system armed will trip the vehicle theft security system.

Interior monitoring is done by the use of an Intrusion Sensor located in the front headliner and with one or two sensors in the ceiling of the cargo area depending on how the vehicle is equipped. Monitoring of the interior of the vehicle will begin after the system has been armed for 30 seconds. The on/off switch located on the instrument panel can be used to turn off this feature with the ignition switch in either the Locked/Off or ACC position. The vehicle tow-monitoring feature can also be switched off using this switch. Re-locking the vehicle a second time will reactivate these features.

If a trailer is connected to the vehicle when the system is armed, the SSM will sense a resistance change on the turn signal circuits if the trailer harness becomes disconnected and will trip the alarm.

Tripping the vehicle theft security system will cause the hazard lamps to flash and the siren to sound at 30-second intervals. The siren is equipped with it's own self-contained battery. In the event the vehicle's battery power is disconnected the siren will continue to sound on it's own.

3.7 USING THE DRBIII®

Refer to the DRBIII® user guide for instructions and assistance with reading trouble codes, erasing trouble codes, and other DRBIII® functions.

3.8 DRBIII® ERROR MESSAGES

Under normal operation, the DRBIII® will display one of only two error messages: user-requested WARM Boot or User-Requested COLD Boot. If the DRBIII® should display any other error message, record the entire display and call the STAR Center. This is a sample of such an error message display:

```

ver: 2.14
date: 26 Jul93
file: key_iff.cc
date: Jul26 1993
line: 548
err: 0xi
User-Requested COLD Boot

Press MORE to switch between this display
and the application screen.
Press F4 when done noting information.
    
```

3.9 DRBIII® DOES NOT POWER UP (BLANK SCREEN)

If the LED's do not light or no sound is emitted at start up, check for loose cable connections or a bad cable. Check the vehicle battery voltage (data link connector cavity 16). A minimum of 11 volts is required to adequately power the DRBIII®. Check for proper grounds at DLC cavities 4 and 5.

If all connections are proper between the DRBIII® and the vehicle or other devices, and the vehicle battery is fully charged, an inoperative DRBIII® may be the result of a faulty cable or vehicle wiring.

3.10 DISPLAY IS NOT VISIBLE

Low temperatures will affect the visibility of the display. Adjust the contrast to compensate for this condition.

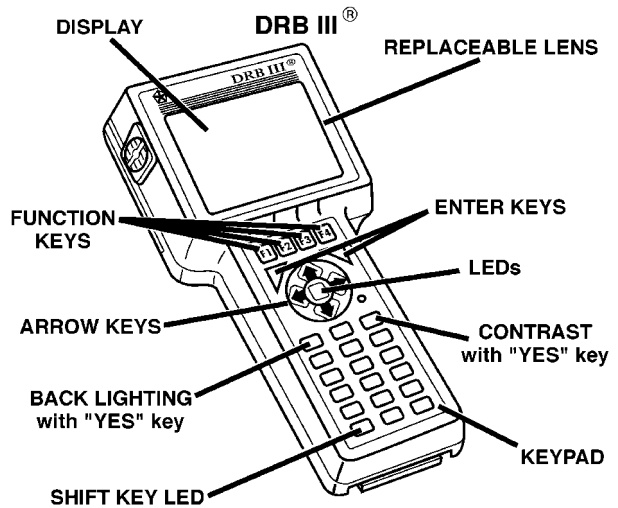

80b57566

4.0 DISCLAIMERS, SAFETY, WARNINGS

4.1 DISCLAIMERS

All information, illustrations, and specifications contained in this manual are based on the latest information available at the time of publication. The right is reserved to make changes at any time without notice.

4.2 SAFETY

4.2.1 TECHNICIAN SAFETY INFORMATION

WARNING: WHEN OPERATING, ENGINES PRODUCE AN ODORLESS GAS CALLED CARBON MONOXIDE. INHALING CARBON MONOXIDE GAS CAN RESULT IN SLOWER REACTION TIMES AND CAN LEAD TO PERSONAL INJURY OR DEATH. WHEN THE ENGINE IS OPERATING, KEEP SERVICE AREAS WELL VENTILATED OR ATTACH THE VEHICLE EXHAUST SYSTEM TO THE SHOP EXHAUST REMOVAL SYSTEM.

Set the parking brake and block the wheel before testing or repairing the vehicle. It is especially important to block the wheels on front-wheel drive vehicles; the parking brake does not hold drive wheels.

When servicing a vehicle, always wear eye protection, and remove any metal jewelry such as rings, watchbands or bracelets that might make an inadvertent electrical contact.

When diagnosing a body system problem, it is important to follow approved procedures where applicable. These procedures can be found in this

GENERAL INFORMATION

General Information Section or in the service manual procedures. Following these procedures is very important to the safety of the individuals performing diagnostic tests.

4.2.2 VEHICLE PREPARATION FOR TESTING

Make sure the vehicle being tested has a fully charged battery. If it does not, false diagnostic codes or error messages may occur.

4.2.3 SERVICING SUB-ASSEMBLIES

Some components of the body system are intended to be serviced as an assembly only. Attempting to remove or repair certain system subcomponents may result in personal injury and/or improper system operation. Only those components with approved repair and installation procedures in the service manual should be serviced.

4.2.4 DRBIII® SAFETY INFORMATION

WARNING: EXCEEDING THE LIMITS OF THE DRBIII® MULTIMETER IS DANGEROUS. READ ALL DRBIII® INSTRUCTIONS BEFORE USING THE MULTIMETER. FAILURE TO FOLLOW THESE INSTRUCTIONS CAN RESULT IN PERSONAL INJURY OR DEATH.

- Follow the vehicle manufacturer's service specifications at all times.
- Do not use the DRBIII® if it has been damaged.
- Do not use the test leads if the insulation is damaged or if metal is exposed.
- To avoid electrical shock, do not touch the test leads, tips, or the circuit being tested.
- Choose the proper range and functions for the measurement. Do not try voltage or current measurement that may exceed the rated capacity.
- Do not exceed the limits shown in the table below:

FUNCTION	INPUT LIMIT
Volts	0 - 500 peak volts AC 0 - 500 volts DC
Ohms (Resistance)*	0 - 1.12 megaohms
Frequency Measure Frequency Generated	0 - 10 kHz
Temperature	-58 - +1100°F -50 - +600°C

* Ohms cannot be measured if voltage is present. Ohms can be measured only on a non-powered circuit.

- Voltage between any terminal and ground must not exceed 500v DC or 500v peak AC.
- Use caution when measuring voltage above 25v DC or 25v AC.
- Use the low current shunt to measure circuits up to 10A. Use the high current clamp to measure circuits exceeding 10A.
- When testing for the presence of voltage or current, make sure the meter is functioning correctly. Take a reading of a known voltage or current before accepting a zero reading.
- When measuring current, connect the meter in series with the load.
- Disconnect the live test lead before disconnecting the common test lead.
- When using the meter function, keep the DRBIII® away from spark plug or coil wires to avoid measuring error from outside interference.

4.3 WARNINGS

4.3.1 VEHICLE DAMAGE WARNINGS

Before disconnecting any control module, make sure the ignition is "off". Failure to do so could damage the module.

When testing voltage or continuity at any control module, use the terminal side (not the wire end) of the connector. Do not probe a wire through the insulation; this will damage it and eventually cause it to fail because of corrosion. Be careful when performing electrical tests so as to prevent accidental shorting of terminals. Such mistakes can damage fuses or components. Also, a second code could be set, making diagnosis of the original problem more difficult.

4.3.2 ROAD TESTING A COMPLAINT VEHICLE

Some complaints will require a test drive as part of the repair verification procedure. The purpose of the test drive is to try to duplicate the diagnostic code or symptom condition.

WARNING: REASSEMBLE ALL COMPONENTS BEFORE ROAD TESTING A VEHICLE. DO NOT TRY TO READ THE DRBIII® SCREEN OR OTHER TEST EQUIPMENT DURING A TEST DRIVE. DO NOT HANG THE DRBIII® OR OTHER TEST EQUIPMENT FROM THE REARVIEW MIRROR DURING A TEST DRIVE. HAVE AN ASSISTANT AVAILABLE TO OPERATE THE DRBIII® OR OTHER TEST EQUIPMENT. FAILURE TO FOLLOW THESE INSTRUCTIONS CAN RESULT IN PERSONAL INJURY OR DEATH.

5.0 REQUIRED TOOLS AND EQUIPMENT

DRBIII® (diagnostic read-out box)
 Jumper wires
 Ohmmeter
 Voltmeter
 Test Light
 8310 Airbag System Load Tool
 8443 SRS Airbag System Load Tool
 9001 R F Detector

6.0 GLOSSARY OF TERMS

ABS	antilock brake system
ACM	airbag control module
ACT	actuator
AECM	airbag electronic control module (ACM)
ASDM	airbag system diagnostic module (ACM)
ATC	automatic temperature control
CAB	controller antilock brake
CAN	controller area network
CHM	cabin heater module
CPA	connector positive assurance
CTM	central timer module
DAB	driver airbag
DCHA	diesel cabin heater assist (cabin heater)
DLC	data link connector
DTC	diagnostic trouble code
DR	driver
EBL	electric back lite (rear window defogger)
ECM	engine control module
GCC	Gulf Coast Countries
HBM	heater booster module
HVAC	heater ventilation, air conditioning
IC	instrument cluster
MIC	mechanical instrument cluster
SA	shifter assembly
SKREEM	sentry key remote entry module
SSM	security system module
TCM	transmission control module

7.0

DIAGNOSTIC INFORMATION AND
PROCEDURES

Symptom:

AIRBAG WARNING INDICATOR - DRIVER HIGH

When Monitored and Set Condition:

AIRBAG WARNING INDICATOR - DRIVER HIGH

When Monitored: With ignition on the ACM monitors the Airbag Warning Indicator Driver circuit for a short to battery voltage.

Set Condition: This DTC will set if the ACM detects voltage on the Airbag Warning Indicator Driver circuit.

POSSIBLE CAUSES

ACM, AIRBAG WARNING LAMP DRIVER CIRCUIT SHORTED TO BATTERY
 CLUSTER SRS INDICATOR SHORTED TO BATTERY
 CLUSTER SRS INDICATOR SHORTED TO BATTERY
 STORED CODE OR INTERMITTENT CONDITION
 ACTIVE CODE PRESENT

TEST	ACTION	APPLICABILITY
1	Turn the ignition on. Ensure the battery is fully charged. NOTE: For the purpose of this test, the AECM and ORC modules will be referred to as an ACM. SELECT ACTIVE or STORED DTC: ACM - ACTIVE DTC Go To 2 ACM - STORED DTC Go To 5 NOTE: When reconnecting Airbag system components, the ignition must be turned off and the battery must be disconnected.	All

AIRBAG WARNING INDICATOR - DRIVER HIGH — Continued

TEST	ACTION	APPLICABILITY
2	<p>WARNING: TO AVOID PERSONAL INJURY OR DEATH, TURN IGNITION OFF, DISCONNECT THE BATTERY AND WAIT TWO MINUTES BEFORE PROCEEDING.</p> <p>Disconnect the Airbag Control Module connector.</p> <p>WARNING: IF THE AIRBAG CONTROL MODULE IS DROPPED AT ANY TIME, IT MUST BE REPLACED. FAILURE TO TAKE THE PROPER PRECAUTIONS COULD RESULT IN ACCIDENTAL AIRBAG DEPLOYMENT AND PERSONAL INJURY OR DEATH.</p> <p>NOTE: Check connectors - Clean and repair as necessary.</p> <p>Connect the Airbag Load Tool ACM Adaptor to the Airbag Control Module connector.</p> <p>WARNING: TO AVOID PERSONAL INJURY OR DEATH, TURN IGNITION ON, THEN RECONNECT THE BATTERY.</p> <p>Measure the voltage of the Airbag Warning Indicator Driver circuit at the ACM adaptor.</p> <p>Is the voltage above 10.0 volts?</p> <p style="padding-left: 40px;">Yes → Go To 3</p> <p style="padding-left: 40px;">No → Go To 4</p>	All
3	<p>Turn the ignition off.</p> <p>Disconnect the Instrument Cluster connectors.</p> <p>NOTE: Check connectors - Clean and repair as necessary.</p> <p>Measure the voltage of the Airbag Warning Indicator Driver circuit at the ACM adaptor.</p> <p>Is the voltage above 10.0 volts?</p> <p style="padding-left: 40px;">Yes → Repair the Airbag Warning Indicator Driver circuit for a short to voltage. Perform AIRBAG VERIFICATION TEST - VER 1.</p> <p style="padding-left: 40px;">No → Replace the Instrument Cluster in accordance with Service Instructions. Perform AIRBAG VERIFICATION TEST - VER 1.</p>	All
4	<p>WARNING: IF THE AIRBAG CONTROL MODULE IS DROPPED AT ANY TIME, IT MUST BE REPLACED. FAILURE TO TAKE THE PROPER PRECAUTIONS COULD RESULT IN ACCIDENTAL AIRBAG DEPLOYMENT AND PERSONAL INJURY OR DEATH.</p> <p>If there are no possible causes remaining, view repair.</p> <p style="padding-left: 40px;">Repair:</p> <p style="padding-left: 80px;">Replace the Airbag Control Module in accordance with Service Instructions. Perform AIRBAG VERIFICATION TEST - VER 1.</p>	All

AIRBAG WARNING INDICATOR - DRIVER HIGH — Continued

TEST	ACTION	APPLICABILITY
5	<p>With the DRBIII®, record and erase all DTC's from all Airbag modules. If equipped with Passenger Airbag On - Off switch, read the DTC's in all switch positions. If any ACTIVE codes are present they must be resolved before diagnosing any stored codes. WARNING: TO AVOID PERSONAL INJURY OR DEATH, TURN THE IGNITION OFF, DISCONNECT THE BATTERY AND WAIT TWO MINUTES BEFORE PROCEEDING. Using the wiring diagram/schematic as a guide, inspect the wiring and connectors. Look for chaffed, pierced, pinched, or partially broken wires and broken, bent, pushed out, spread, corroded, or contaminated terminals. The following additional checks may assist you in identifying a possible intermittent problem. Reconnect any disconnected components and harness connector. WARNING: TO AVOID PERSONAL INJURY OR DEATH, TURN THE IGNITION ON, THEN RECONNECT THE BATTERY. With the DRBIII® monitor active codes as you work through the following steps. WARNING: TO AVOID PERSONAL INJURY OR DEATH, MAINTAIN A SAFE DISTANCE FROM ALL AIRBAGS WHILE PERFORMING THE FOLLOWING STEPS. Wiggle the wiring harness and connectors of the related airbag circuit or component. If codes are related to the Driver circuits, rotate the steering wheel from stop to stop. You have just attempted to simulate the condition that initially set the trouble code message. Did the DTC become active?</p> <p style="padding-left: 40px;">Yes → Select appropriate symptom from Symptom List.</p> <p style="padding-left: 40px;">No → No problem found at this time. Erase all codes before returning vehicle to customer.</p>	All

Symptom:

AIRBAG WARNING INDICATOR - DRIVER LOW

When Monitored and Set Condition:

AIRBAG WARNING INDICATOR - DRIVER LOW

When Monitored: With ignition on the ACM monitors the Airbag Warning Indicator Driver circuit for an open, high resistance, or short to ground.

Set Condition: This DTC will set if the ACM detects a short to ground or open Airbag Warning Indicator Driver circuit.

POSSIBLE CAUSES

CLUSTER SRS INDICATOR OPEN
 ACM, AIRBAG WARNING LAMP DRIVER CIRCUIT OPEN
 OPEN AIRBAG WARNING INDICATOR DRIVER
 ACM, WARNING INDICATOR CIRCUIT LOW
 AIRBAG WARNING INDICATOR DRIVER SHORT TO GROUND
 STORED CODE OR INTERMITTENT CONDITION
 ACTIVE CODE PRESENT

TEST	ACTION	APPLICABILITY
1	Turn the ignition on. Ensure the battery is fully charged. NOTE: For the purpose of this test, the AECM and ORC modules will be referred to as an ACM. SELECT ACTIVE or STORED DTC: ACM - ACTIVE DTC Go To 2 ACM - STORED DTC Go To 8 NOTE: When reconnecting Airbag system components, the ignition must be turned off and the battery must be disconnected.	All

AIRBAG WARNING INDICATOR - DRIVER LOW — Continued

TEST	ACTION	APPLICABILITY
2	<p>WARNING: TO AVOID PERSONAL INJURY OR DEATH, TURN IGNITION OFF, DISCONNECT THE BATTERY AND WAIT TWO MINUTES BEFORE PROCEEDING.</p> <p>Disconnect the Airbag Control Module connector.</p> <p>WARNING: IF THE AIRBAG CONTROL MODULE IS DROPPED AT ANY TIME, IT MUST BE REPLACED. FAILURE TO TAKE THE PROPER PRECAUTIONS COULD RESULT IN ACCIDENTAL AIRBAG DEPLOYMENT AND PERSONAL INJURY OR DEATH.</p> <p>NOTE: Check connectors - Clean and repair as necessary.</p> <p>Connect the Airbag Load Tool ACM Adaptor to the Airbag Control Module connector.</p> <p>WARNING: TO AVOID PERSONAL INJURY OR DEATH, TURN IGNITION ON, THEN RECONNECT THE BATTERY.</p> <p>Measure the voltage of the Airbag Warning Indicator Driver circuit at the ACM adaptor.</p> <p>Is the voltage above 9.0 volts?</p> <p style="padding-left: 40px;">Yes → Go To 3</p> <p style="padding-left: 40px;">No → Go To 5</p>	All
3	<p>Turn the ignition off.</p> <p>Connect a jumper between the Airbag Warning Indicator Driver circuit at the ACM Adaptor and ground.</p> <p>Turn the ignition on.</p> <p>Observe the SRS indicator while turning the ignition on.</p> <p>Does the SRS indicator illuminate?</p> <p style="padding-left: 40px;">Yes → Go To 4</p> <p style="padding-left: 40px;">No → Replace the Instrument Cluster in accordance with Service Instructions.</p> <p style="padding-left: 40px;">Perform AIRBAG VERIFICATION TEST - VER 1.</p>	All
4	<p>WARNING: TO AVOID PERSONAL INJURY OR DEATH, TURN IGNITION OFF, DISCONNECT THE BATTERY AND WAIT TWO MINUTES BEFORE PROCEEDING.</p> <p>WARNING: IF THE AIRBAG CONTROL MODULE IS DROPPED AT ANY TIME, IT MUST BE REPLACED. FAILURE TO TAKE THE PROPER PRECAUTIONS COULD RESULT IN ACCIDENTAL AIRBAG DEPLOYMENT AND PERSONAL INJURY OR DEATH.</p> <p>If there are no possible causes remaining, view repair.</p> <p style="padding-left: 40px;">Repair:</p> <p style="padding-left: 80px;">Replace the Airbag Control Module in accordance with Service Instructions.</p> <p style="padding-left: 80px;">Perform AIRBAG VERIFICATION TEST - VER 1.</p>	All
5	<p>Turn the ignition off.</p> <p>Disconnect the Instrument Cluster connectors.</p> <p>NOTE: Check connectors - Clean and repair as necessary.</p> <p>Measure the resistance of the Airbag Warning Lamp Driver circuit between the ACM Adaptor and Instrument Cluster Connector.</p> <p>Is the resistance below 5.0 ohms?</p> <p style="padding-left: 40px;">Yes → Go To 6</p> <p style="padding-left: 40px;">No → Repair the open or high resistance in the Airbag Warning Indicator Driver circuit.</p> <p style="padding-left: 40px;">Perform AIRBAG VERIFICATION TEST - VER 1.</p>	All

AIRBAG WARNING INDICATOR - DRIVER LOW — Continued

TEST	ACTION	APPLICABILITY
6	<p>Measure the resistance of the Airbag Warning Lamp Driver circuit between the Airbag Control Module Adaptor and ground. Is the resistance below 5.0 ohms?</p> <p>Yes → Repair the Airbag Warning Indicator Driver circuit shorted to ground. Perform AIRBAG VERIFICATION TEST - VER 1.</p> <p>No → Go To 7</p>	All
7	<p>WARNING: TO AVOID PERSONAL INJURY OR DEATH, TURN IGNITION OFF, DISCONNECT THE BATTERY AND WAIT TWO MINUTES BEFORE PROCEEDING.</p> <p>WARNING: IF THE AIRBAG CONTROL MODULE IS DROPPED AT ANY TIME, IT MUST BE REPLACED. FAILURE TO TAKE THE PROPER PRECAUTIONS COULD RESULT IN ACCIDENTAL AIRBAG DEPLOYMENT AND PERSONAL INJURY OR DEATH.</p> <p>If there are no possible causes remaining, view repair.</p> <p>Repair: Replace the Airbag Control Module in accordance with the Service Information. Perform AIRBAG VERIFICATION TEST - VER 1.</p>	All
8	<p>With the DRBIII®, record and erase all DTC's from all Airbag modules. If equipped with Passenger Airbag On - Off switch, read the DTC's in all switch positions. If any ACTIVE codes are present they must be resolved before diagnosing any stored codes.</p> <p>WARNING: TO AVOID PERSONAL INJURY OR DEATH, TURN THE IGNITION OFF, DISCONNECT THE BATTERY AND WAIT TWO MINUTES BEFORE PROCEEDING.</p> <p>Using the wiring diagram/schematic as a guide, inspect the wiring and connectors. Look for chaffed, pierced, pinched, or partially broken wires and broken, bent, pushed out, spread, corroded, or contaminated terminals. The following additional checks may assist you in identifying a possible intermittent problem. Reconnect any disconnected components and harness connector.</p> <p>WARNING: TO AVOID PERSONAL INJURY OR DEATH, TURN THE IGNITION ON, THEN RECONNECT THE BATTERY.</p> <p>With the DRBIII® monitor active codes as you work through the following steps. WARNING: TO AVOID PERSONAL INJURY OR DEATH, MAINTAIN A SAFE DISTANCE FROM ALL AIRBAGS WHILE PERFORMING THE FOLLOWING STEPS.</p> <p>Wiggle the wiring harness and connectors of the related airbag circuit or component. If codes are related to the Driver circuits, rotate the steering wheel from stop to stop. You have just attempted to simulate the condition that initially set the trouble code message. Did the DTC become active?</p> <p>Yes → Select appropriate symptom from Symptom List.</p> <p>No → No problem found at this time. Erase all codes before returning vehicle to customer.</p>	All

Symptom List:

DRIVER SEAT BELT TENSIONER - INCORRECT FEEDBACK

DRIVER SQUIB 1 - INCORRECT FEEDBACK

INTERNAL 1

INTERNAL 2

INTERNAL 3

PASSENGER SEAT BELT TENSIONER - INCORRECT FEEDBACK

PASSENGER SQUIB 1 - INCORRECT FEEDBACK

STORED ENERGY FIRING 1

STORED ENERGY FIRING 2

Test Note: All symptoms listed above are diagnosed using the same tests. The title for the tests will be DRIVER SEAT BELT TENSIONER - INCORRECT FEEDBACK.

When Monitored and Set Condition:

INTERNAL 1

When Monitored: With the ignition on, the module on board diagnostics continuously performs internal circuit tests.

Set Condition: This DTC will set if the module identifies an out of range internal circuit.

INTERNAL 2

When Monitored: With the ignition on, the module on board diagnostics continuously performs internal circuit tests.

Set Condition: This DTC will set if the module identifies an out of range internal circuit.

INTERNAL 3

When Monitored: With the ignition on, the module on board diagnostics continuously performs internal circuit tests.

Set Condition: This DTC will set if the module identifies an out of range internal circuit.

STORED ENERGY FIRING 1

When Monitored: With the ignition on, the module on board diagnostics continuously performs internal circuit voltage tests.

Set Condition: This DTC will set if the ACM identifies an internal high voltages condition.

DRIVER SEAT BELT TENSIONER - INCORRECT FEEDBACK — Continued**STORED ENERGY FIRING 2**

When Monitored: With the ignition on, the module on board diagnostics continuously performs internal voltage tests.

Set Condition: This DTC will set if the ACM identifies an internal low voltages condition.

POSSIBLE CAUSES

AIRBAG CONTROL MODULE - ACM

TEST	ACTION	APPLICABILITY
1	<p>Turn the ignition on. NOTE: Ensure the battery is fully charged. NOTE: For the purpose of this test, the AECM and ORC modules will be referred to as an ACM. WARNING: TO AVOID PERSONAL INJURY OR DEATH, TURN THE IGNITION OFF, DISCONNECT THE BATTERY AND WAIT TWO MINUTES BEFORE PROCEEDING. WARNING: TO AVOID PERSONAL INJURY OR DEATH, IF THE MODULE IS DROPPED AT ANY TIME, IT MUST BE REPLACED. Select the appropriate module and DTC type combination:</p> <p>ACM - ACTIVE DTC Replace the Airbag Control Module in accordance with Service Instructions. Perform AIRBAG VERIFICATION TEST - VER 1.</p> <p>ACM - STORED DTC Replace the Airbag Control Module in accordance with Service Instructions. Perform AIRBAG VERIFICATION TEST - VER 1.</p> <p>NOTE: When reconnecting Airbag system components, the ignition must be turned off and the battery must be disconnected.</p>	All

Symptom:

DRIVER SEAT BELT TENSIONER CIRCUIT OPEN

When Monitored and Set Condition:

DRIVER SEAT BELT TENSIONER CIRCUIT OPEN

When Monitored: With the ignition on the ACM monitors the resistance of the Driver Seat Belt Tensioner circuits.

Set Condition: The ACM has detected an open circuit or high resistance on the Driver Seat Belt Tensioner circuits.

POSSIBLE CAUSES

DRIVER SEAT BELT TENSIONER CIRCUITS OPEN
 DRIVER SEAT BELT TENSIONER LINE 1 OR LINE 2 CIRCUIT OPEN
 ACM, DRIVER SEAT BELT TENSIONER CIRCUIT OPEN
 STORED CODE OR INTERMITTENT CONDITION
 ACTIVE CODE PRESENT

TEST	ACTION	APPLICABILITY
1	Turn the ignition on. NOTE: Ensure the battery is fully charged. NOTE: For the purpose of this test, the AECM and ORC modules will be referred to as an ACM. SELECT ACTIVE or STORED DTC: ACM - ACTIVE DTC Go To 2 ACM - STORED DTC Go To 5 NOTE: When reconnecting Airbag system components, the ignition must be turned off and the battery must be disconnected.	All
2	NOTE: Ensure the battery is fully charged. WARNING: TO AVOID PERSONAL INJURY OR DEATH, TURN IGNITION OFF, DISCONNECT THE BATTERY AND WAIT TWO MINUTES BEFORE PROCEEDING. Disconnect the Driver Seat Belt Tensioner connector. NOTE: Check connectors - Clean and repair as necessary. Connect the appropriate Load Tool to the Driver Seat Belt Tensioner connector. WARNING: TO AVOID PERSONAL INJURY OR DEATH, TURN IGNITION ON, THEN RECONNECT THE BATTERY. With the DRBIII®, read active Airbag Control Module DTC's. Does the DRBIII® display DRIVER SBT CIRCUIT OPEN? Yes → Go To 3 No → Replace Driver Seat Belt Tensioner in accordance with the Service Information. Perform AIRBAG VERIFICATION TEST - VER 1.	All

DRIVER SEAT BELT TENSIONER CIRCUIT OPEN — Continued

TEST	ACTION	APPLICABILITY
3	<p>WARNING: TO AVOID PERSONAL INJURY OR DEATH, TURN IGNITION OFF, DISCONNECT THE BATTERY AND WAIT TWO MINUTES BEFORE PROCEEDING.</p> <p>Disconnect the Load Tool from the Driver Seat Belt Tensioner connector. Disconnect the Airbag Control Module Connector(s). NOTE: Check connectors - Clean and repair as necessary. Connect the appropriate Load Tool ACM Adaptor to the Airbag Control Module connector(s). Measure the resistance of the Driver SBT Line 1 and Line 2 circuits between the Load Tool Adapter and the Driver SBT connector. Is the resistance below 1.0 ohms on both circuit?</p> <p>Yes → Go To 4</p> <p>No → Repair open or high resistance in Driver Seat Belt Tensioner Line 1 Line 2 circuits. Perform AIRBAG VERIFICATION TEST - VER 1.</p>	All
4	<p>WARNING: IF THE AIRBAG CONTROL MODULE IS DROPPED AT ANY TIME, IT MUST BE REPLACED. FAILURE TO TAKE THE PROPER PRECAUTIONS COULD RESULT IN ACCIDENTAL AIRBAG DEPLOYMENT AND PERSONAL INJURY OR DEATH.</p> <p>If there are no possible causes remaining, view repair.</p> <p>Repair:</p> <p>Replace the Airbag Control Module in accordance with the Service information. Perform AIRBAG VERIFICATION TEST - VER 1.</p>	All
5	<p>With the DRBIII®, record and erase all DTC's from all Airbag modules. If equipped with Passenger Airbag On - Off switch, read the DTC's in all switch positions. If any ACTIVE codes are present they must be resolved before diagnosing any stored codes.</p> <p>WARNING: TO AVOID PERSONAL INJURY OR DEATH, TURN THE IGNITION OFF, DISCONNECT THE BATTERY AND WAIT TWO MINUTES BEFORE PROCEEDING.</p> <p>Using the wiring diagram/schematic as a guide, inspect the wiring and connectors. Look for chaffed, pierced, pinched, or partially broken wires and broken, bent, pushed out, spread, corroded, or contaminated terminals. The following additional checks may assist you in identifying a possible intermittent problem. Reconnect any disconnected components and harness connector.</p> <p>WARNING: TO AVOID PERSONAL INJURY OR DEATH, TURN THE IGNITION ON, THEN RECONNECT THE BATTERY.</p> <p>With the DRBIII® monitor active codes as you work through the following steps. WARNING: TO AVOID PERSONAL INJURY OR DEATH, MAINTAIN A SAFE DISTANCE FROM ALL AIRBAGS WHILE PERFORMING THE FOLLOWING STEPS.</p> <p>Wiggle the wiring harness and connectors of the related airbag circuit or component. If codes are related to the Driver circuits, rotate the steering wheel from stop to stop. You have just attempted to simulate the condition that initially set the trouble code message. Did the DTC become active?</p> <p>Yes → Select appropriate symptom from Symptom List.</p> <p>No → No problem found at this time. Erase all codes before returning vehicle to customer.</p>	All

Symptom:

DRIVER SEAT BELT TENSIONER CIRCUIT SHORT

When Monitored and Set Condition:

DRIVER SEAT BELT TENSIONER CIRCUIT SHORT

When Monitored: With the ignition on the ACM monitors the resistance of the Driver Seat Belt Tensioner circuits

Set Condition: The ACM has detected low resistance in the Driver Seat Belt Tensioner circuits.

POSSIBLE CAUSES

DRIVER SEAT BELT TENSIONER SHORT
 DRIVER SEAT BELT TENSIONER LINE 1 SHORT TO LINE 2
 ACM, DRIVER SEAT BELT TENSIONER CIRCUIT SHORT
 STORED CODE OR INTERMITTENT CONDITION
 ACTIVE CODE PRESENT

TEST	ACTION	APPLICABILITY
1	Turn the ignition on. NOTE: Ensure the battery is fully charged. NOTE: For the purpose of this test, the AECM and ORC modules will be referred to as an ACM. SELECT ACTIVE or STORED DTC: ACM - ACTIVE DTC Go To 2 ACM - STORED DTC Go To 5 NOTE: When reconnecting airbag system components the Ignition must be turned off and the Battery must be disconnected.	All
2	WARNING: TO AVOID PERSONAL INJURY OR DEATH, TURN IGNITION OFF, DISCONNECT THE BATTERY AND WAIT TWO MINUTES BEFORE PROCEEDING. Disconnect the Driver Seat Belt Tensioner connector. NOTE: Check connectors - Clean and repair as necessary. Connect the appropriate Load Tool to the Driver Seat Belt Tensioner connector. WARNING: TO AVOID PERSONAL INJURY OR DEATH, TURN IGNITION ON, THEN RECONNECT THE BATTERY. With the DRBIII®, read active Airbag Control Module DTC's. Does the DRBIII® display DRIVER SEAT BELT TENSIONER CIRCUIT SHORT? Yes → Go To 3 No → Replace Driver Seat Belt Tensioner in accordance with the Service Information. Perform AIRBAG VERIFICATION TEST - VER 1.	All

DRIVER SEAT BELT TENSIONER CIRCUIT SHORT — Continued

TEST	ACTION	APPLICABILITY
3	<p>WARNING: TO AVOID PERSONAL INJURY OR DEATH, TURN IGNITION OFF, DISCONNECT THE BATTERY AND WAIT TWO MINUTES BEFORE PROCEEDING.</p> <p>Disconnect the Load Tool from the Driver Seat Belt Tensioner connector. Disconnect the Airbag Control Module connector(s). NOTE: Check connectors - Clean and repair as necessary. Connect the appropriate Load Tool ACM Adaptor to the Airbag Control Module connector(s). Measure the resistance between the Driver SBT Line 1 and Line 2 circuit at the Driver SBT connector. Is the resistance below 10K Ohms?</p> <p>Yes → Repair Driver Seat Belt Tensioner Line 1 circuit short to Driver Seat Belt Tensioner Line 2 circuit. Perform AIRBAG VERIFICATION TEST - VER 1.</p> <p>No → Go To 4</p>	All
4	<p>WARNING: IF THE AIRBAG CONTROL MODULE IS DROPPED AT ANY TIME, IT MUST BE REPLACED. FAILURE TO TAKE THE PROPER PRECAUTIONS COULD RESULT IN ACCIDENTAL AIRBAG DEPLOYMENT AND PERSONAL INJURY OR DEATH.</p> <p>If there are no possible causes remaining, view repair.</p> <p>Repair:</p> <p>Replace the Airbag Control Module in accordance with the Service Information. WARNING: IF THE AIRBAG CONTROL MODULE IS DROPPED AT ANY TIME, IT MUST BE REPLACED. Perform AIRBAG VERIFICATION TEST - VER 1.</p>	All
5	<p>With the DRBIII®, record and erase all DTC's from all Airbag modules. If equipped with Passenger Airbag On - Off switch, read the DTC's in all switch positions. If any ACTIVE codes are present they must be resolved before diagnosing any stored codes.</p> <p>WARNING: TO AVOID PERSONAL INJURY OR DEATH, TURN THE IGNITION OFF, DISCONNECT THE BATTERY AND WAIT TWO MINUTES BEFORE PROCEEDING.</p> <p>Using the wiring diagram/schematic as a guide, inspect the wiring and connectors. Look for chaffed, pierced, pinched, or partially broken wires and broken, bent, pushed out, spread, corroded, or contaminated terminals. The following additional checks may assist you in identifying a possible intermittent problem. Reconnect any disconnected components and harness connector. WARNING: TO AVOID PERSONAL INJURY OR DEATH, TURN THE IGNITION ON, THEN RECONNECT THE BATTERY.</p> <p>With the DRBIII® monitor active codes as you work through the following steps. WARNING: TO AVOID PERSONAL INJURY OR DEATH, MAINTAIN A SAFE DISTANCE FROM ALL AIRBAGS WHILE PERFORMING THE FOLLOWING STEPS.</p> <p>Wiggle the wiring harness and connectors of the related airbag circuit or component. If codes are related to the Driver circuits, rotate the steering wheel from stop to stop. You have just attempted to simulate the condition that initially set the trouble code message. Did the DTC become active?</p> <p>Yes → Select appropriate symptom from Symptom List.</p> <p>No → No problem found at this time. Erase all codes before returning vehicle to customer.</p>	All

Symptom:

DRIVER SEAT BELT TENSIONER SHORT TO BATTERY

When Monitored and Set Condition:

DRIVER SEAT BELT TENSIONER SHORT TO BATTERY

When Monitored: With the ignition on the ACM monitors the voltage of the Driver Seat Belt Tensioner circuits.

Set Condition: The ACM has detected high voltage on the Driver Seat Belt Tensioner circuits.

POSSIBLE CAUSES

DRIVER SEAT BELT TENSIONER SHORT TO BATTERY
 DRIVER SBT LINE 1 OR LINE 2 SHORT TO BATTERY
 ACM, DRIVER SEAT BELT TENSIONER SHORT TO BATTERY
 STORED CODE OR INTERMITTENT CONDITION
 ACTIVE CODE PRESENT

TEST	ACTION	APPLICABILITY
1	Turn the ignition on. NOTE: Ensure the battery is fully charged. NOTE: For the purpose of this test, the AECM and ORC modules will be referred to as an ACM. SELECT ACTIVE or STORED DTC: ACM - ACTIVE DTC Go To 2 ACM - STORED DTC Go To 5 NOTE: When reconnecting airbag system components the Ignition must be turned off and the Battery must be disconnected.	All
2	WARNING: TO AVOID PERSONAL INJURY OR DEATH, TURN IGNITION OFF, DISCONNECT THE BATTERY AND WAIT TWO MINUTES BEFORE PROCEEDING. Disconnect the Driver Seat Belt Tensioner connector. NOTE: Check connectors - Clean and repair as necessary. Connect the appropriate Load Tool to the Driver Seat Belt Tensioner connector. WARNING: TO AVOID PERSONAL INJURY OR DEATH, TURN IGNITION ON, THEN RECONNECT THE BATTERY. With the DRBIII®, read the active Airbag Control Module DTC's. Does the DRBIII® display DRIVER SEAT BELT TENSIONER SHORT TO BATTERY? Yes → Go To 3 No → Replace Driver Seat Belt Tensioner in accordance with the Service Information. Perform AIRBAG VERIFICATION TEST - VER 1.	All

DRIVER SEAT BELT TENSIONER SHORT TO BATTERY — Continued

TEST	ACTION	APPLICABILITY
3	<p>WARNING: TO AVOID PERSONAL INJURY OR DEATH, TURN IGNITION OFF, DISCONNECT THE BATTERY AND WAIT TWO MINUTES BEFORE PROCEEDING.</p> <p>Disconnect the Load Tool from the Driver Seat Belt Tensioner connector. Disconnect the Airbag Control Module Connector(s). NOTE: Check connectors - Clean and repair as necessary. Connect the appropriate Load Tool ACM Adaptor to the Airbag Control Module connector(s). WARNING: TO AVOID PERSONAL INJURY OR DEATH, TURN IGNITION ON, THEN RECONNECT THE BATTERY. Measure the voltage of the Driver SBT Line 1 and Line 2 circuits between the Driver SBT connector and ground. Is there any voltage present?</p> <p style="padding-left: 40px;">Yes → Repair Driver Seat Belt Tensioner Line 1 or Line 2 circuit short to battery. Perform AIRBAG VERIFICATION TEST - VER 1.</p> <p style="padding-left: 40px;">No → Go To 4</p>	All
4	<p>WARNING: IF THE AIRBAG CONTROL MODULE IS DROPPED AT ANY TIME, IT MUST BE REPLACED. FAILURE TO TAKE THE PROPER PRECAUTIONS COULD RESULT IN ACCIDENTAL AIRBAG DEPLOYMENT AND PERSONAL INJURY OR DEATH.</p> <p>If there are no possible causes remaining, view repair.</p> <p style="padding-left: 40px;">Repair: Replace the Airbag Control Module in accordance with the Service Information. WARNING: IF THE AIRBAG CONTROL MODULE IS DROPPED AT ANY TIME, IT MUST BE REPLACED. Perform AIRBAG VERIFICATION TEST - VER 1.</p>	All

DRIVER SEAT BELT TENSIONER SHORT TO BATTERY — Continued

TEST	ACTION	APPLICABILITY
5	<p>With the DRBIII®, record and erase all DTC's from all Airbag modules. If equipped with Passenger Airbag On - Off switch, read the DTC's in all switch positions. If any ACTIVE codes are present they must be resolved before diagnosing any stored codes. WARNING: TO AVOID PERSONAL INJURY OR DEATH, TURN THE IGNITION OFF, DISCONNECT THE BATTERY AND WAIT TWO MINUTES BEFORE PROCEEDING. Using the wiring diagram/schematic as a guide, inspect the wiring and connectors. Look for chaffed, pierced, pinched, or partially broken wires and broken, bent, pushed out, spread, corroded, or contaminated terminals. The following additional checks may assist you in identifying a possible intermittent problem. Reconnect any disconnected components and harness connector. WARNING: TO AVOID PERSONAL INJURY OR DEATH, TURN THE IGNITION ON, THEN RECONNECT THE BATTERY. With the DRBIII® monitor active codes as you work through the following steps. WARNING: TO AVOID PERSONAL INJURY OR DEATH, MAINTAIN A SAFE DISTANCE FROM ALL AIRBAGS WHILE PERFORMING THE FOLLOWING STEPS. Wiggle the wiring harness and connectors of the related airbag circuit or component. If codes are related to the Driver circuits, rotate the steering wheel from stop to stop. You have just attempted to simulate the condition that initially set the trouble code message. Did the DTC become active?</p> <p style="padding-left: 40px;">Yes → Select appropriate symptom from Symptom List.</p> <p style="padding-left: 40px;">No → No problem found at this time. Erase all codes before returning vehicle to customer.</p>	All

Symptom:

DRIVER SEAT BELT TENSIONER SHORT TO GROUND

When Monitored and Set Condition:

DRIVER SEAT BELT TENSIONER SHORT TO GROUND

When Monitored: With the ignition on the ACM monitors the voltage of the Driver Seat Belt Tensioner circuits.

Set Condition: When the ACM detects a short to ground in either Driver Seat Belt Tensioner circuits.

POSSIBLE CAUSES

DRIVER SEAT BELT TENSIONER SHORT TO GROUND
 DRIVER SEAT BELT LINE 1 OR LINE 2 SHORT TO GROUND
 ACM, DRIVER SEAT BELT TENSIONER SHORT TO GROUND
 STORED CODE OR INTERMITTENT CONDITION
 ACTIVE CODE PRESENT

TEST	ACTION	APPLICABILITY
1	Turn the ignition on. NOTE: Ensure the battery is fully charged. NOTE: For the purpose of this test, the AECM and ORC modules will be referred to as an ACM. SELECT ACTIVE or STORED DTC: ACM - ACTIVE DTC Go To 2 ACM - STORED DTC Go To 5 NOTE: When reconnecting airbag system components the Ignition must be turned off and the Battery must be disconnected.	All
2	WARNING: TO AVOID PERSONAL INJURY OR DEATH, TURN IGNITION OFF, DISCONNECT THE BATTERY AND WAIT TWO MINUTES BEFORE PROCEEDING. Disconnect the Driver Seat Belt Tensioner connector. NOTE: Check connectors - Clean and repair as necessary. Connect the appropriate Load Tool to the Driver Seat Belt Tensioner connector. WARNING: TO AVOID PERSONAL INJURY OR DEATH, TURN IGNITION ON, THEN RECONNECT THE BATTERY. With the DRBIII®, read the active Airbag Control Module DTC's. Does the DRBIII® display DRIVER SEAT BELT TENSIONER SHORT TO GROUND? Yes → Go To 3 No → Replace the Driver Seat Belt Tensioner in accordance with the Service Information. Perform AIRBAG VERIFICATION TEST - VER 1.	All

DRIVER SEAT BELT TENSIONER SHORT TO GROUND — Continued

TEST	ACTION	APPLICABILITY
3	<p>WARNING: TO AVOID PERSONAL INJURY OR DEATH, TURN IGNITION OFF, DISCONNECT THE BATTERY AND WAIT TWO MINUTES BEFORE PROCEEDING.</p> <p>Disconnect the Load Tool from the Driver Seat Belt Tensioner connector. Disconnect the Airbag Control Module connector(s). NOTE: Check connectors - Clean and repair as necessary. Connect the appropriate Load Tool ACM Adaptor to the Airbag Control Module connector(s). Measure the resistance of the Driver SBT Line 1 and Line 2 circuits between the Driver SBT connector and ground. Is the resistance below 10K ohms on either circuit?</p> <p>Yes → Repair Driver Seat Belt Tensioner Line 1 or Line 2 circuits short to ground. Perform AIRBAG VERIFICATION TEST - VER 1.</p> <p>No → Go To 4</p>	All
4	<p>WARNING: IF THE AIRBAG CONTROL MODULE IS DROPPED AT ANY TIME, IT MUST BE REPLACED. FAILURE TO TAKE THE PROPER PRECAUTIONS COULD RESULT IN ACCIDENTAL AIRBAG DEPLOYMENT AND PERSONAL INJURY OR DEATH.</p> <p>If there are no possible causes remaining, view repair.</p> <p>Repair: Replace the Airbag Control Module in accordance with the Service information. Perform AIRBAG VERIFICATION TEST - VER 1.</p>	All
5	<p>With the DRBIII®, record and erase all DTC's from all Airbag modules. If equipped with Passenger Airbag On - Off switch, read the DTC's in all switch positions. If any ACTIVE codes are present they must be resolved before diagnosing any stored codes.</p> <p>WARNING: TO AVOID PERSONAL INJURY OR DEATH, TURN THE IGNITION OFF, DISCONNECT THE BATTERY AND WAIT TWO MINUTES BEFORE PROCEEDING.</p> <p>Using the wiring diagram/schematic as a guide, inspect the wiring and connectors. Look for chaffed, pierced, pinched, or partially broken wires and broken, bent, pushed out, spread, corroded, or contaminated terminals. The following additional checks may assist you in identifying a possible intermittent problem. Reconnect any disconnected components and harness connector.</p> <p>WARNING: TO AVOID PERSONAL INJURY OR DEATH, TURN THE IGNITION ON, THEN RECONNECT THE BATTERY.</p> <p>With the DRBIII® monitor active codes as you work through the following steps. WARNING: TO AVOID PERSONAL INJURY OR DEATH, MAINTAIN A SAFE DISTANCE FROM ALL AIRBAGS WHILE PERFORMING THE FOLLOWING STEPS.</p> <p>Wiggle the wiring harness and connectors of the related airbag circuit or component. If codes are related to the Driver circuits, rotate the steering wheel from stop to stop. You have just attempted to simulate the condition that initially set the trouble code message. Did the DTC become active?</p> <p>Yes → Select appropriate symptom from Symptom List.</p> <p>No → No problem found at this time. Erase all codes before returning vehicle to customer.</p>	All

Symptom:
DRIVER SQUIB 1 CIRCUIT OPEN

When Monitored and Set Condition:

DRIVER SQUIB 1 CIRCUIT OPEN

When Monitored: With the ignition on, the ACM monitors the resistance of the Driver Squib 1 circuits.

Set Condition: The ACM detects an open circuit or high resistance in the Driver Squib 1 circuits.

POSSIBLE CAUSES

DRIVER AIRBAG SQUIB 1 CIRCUIT OPEN
 CLOCKSPRING SQUIB 1 CIRCUIT OPEN
 DRIVER SQUIB 1 LINE 1 OR LINE 2 CIRCUITS OPEN
 ACM, DRIVER SQUIB 1 CIRCUIT OPEN
 STORED CODE OR INTERMITTENT CONDITION
 ACTIVE CODE PRESENT

TEST	ACTION	APPLICABILITY
1	Turn the ignition on. NOTE: Ensure the battery is fully charged. NOTE: For the purpose of this test, the AECM and ORC modules will be referred to as an ACM. SELECT ACTIVE or STORED DTC: ACM - ACTIVE DTC Go To 2 ACM - STORED DTC Go To 6 NOTE: When reconnecting Airbag system components, the ignition must be turned off and the battery must be disconnected.	All

DRIVER SQUIB 1 CIRCUIT OPEN — Continued

TEST	ACTION	APPLICABILITY
2	<p>WARNING: TO AVOID PERSONAL INJURY OR DEATH, TURN THE IGNITION OFF, DISCONNECT THE BATTERY AND WAIT TWO MINUTES BEFORE PROCEEDING.</p> <p>Disconnect the Driver Airbag Squib connector(s).</p> <p>NOTE: Check connectors - Clean and repair as necessary.</p> <p>WARNING: TO AVOID PERSONAL INJURY OR DEATH, DO NOT PLACE AN INTACT UNDEPLOYED AIRBAG FACE DOWN ON A HARD SURFACE, THE AIRBAG WILL PROPEL INTO THE AIR IF ACCIDENTALLY DEPLOYED.</p> <p>Connect the appropriate Load Tool to the Driver Airbag connector(s).</p> <p>WARNING: TO AVOID PERSONAL INJURY OR DEATH, TURN THE IGNITION ON, THEN RECONNECT THE BATTERY.</p> <p>With the DRBIII®, read the active Airbag Control Module DTC's.</p> <p>Does the DRBIII® show DRIVER SQUIB 1 CIRCUIT OPEN?</p> <p>Yes → Go To 3</p> <p>No → Replace the Driver Airbag in accordance with the Service Information.</p> <p>Perform AIRBAG VERIFICATION TEST - VER 1.</p>	All
3	<p>WARNING: TO AVOID PERSONAL INJURY OR DEATH, TURN THE IGNITION OFF, DISCONNECT THE BATTERY AND WAIT TWO MINUTES BEFORE PROCEEDING.</p> <p>Disconnect the Load Tool from the Driver Airbag connector(s).</p> <p>Disconnect the Clockspring connector(s).</p> <p>NOTE: Check connectors - Clean and repair as necessary.</p> <p>Connect the appropriate Load Tool to the Clockspring connector(s).</p> <p>WARNING: TO AVOID PERSONAL INJURY OR DEATH, TURN THE IGNITION ON, THEN RECONNECT THE BATTERY.</p> <p>With the DRBIII®, read the active Airbag Control Module DTC's.</p> <p>Does the DRBIII® show DRIVER SQUIB 1 CIRCUIT OPEN?</p> <p>Yes → Go To 4</p> <p>No → Replace the Clockspring in accordance with the Service Information.</p> <p>Perform AIRBAG VERIFICATION TEST - VER 1.</p>	All
4	<p>WARNING: TO AVOID PERSONAL INJURY OR DEATH, TURN THE IGNITION OFF, DISCONNECT THE BATTERY AND WAIT TWO MINUTES BEFORE PROCEEDING.</p> <p>Disconnect the Load Tool from the Clockspring connector(s).</p> <p>Disconnect the Airbag Control Module connector(s).</p> <p>NOTE: Check connectors - Clean and repair as necessary.</p> <p>Connect the appropriate Load Tool Adaptor to the Airbag Control Module connector(s).</p> <p>Measure the resistance of the Driver Squib 1 Line 1 and Line 2 circuits between the ACM Adaptor and the Clockspring connector(s).</p> <p>Is the resistance below 1.0 ohm on both circuits?</p> <p>Yes → Go To 5</p> <p>No → Repair open or high resistance in the Driver Squib 1 Line 1 or Line 2 circuits.</p> <p>Perform AIRBAG VERIFICATION TEST - VER 1.</p>	All

DRIVER SQUIB 1 CIRCUIT OPEN — Continued

TEST	ACTION	APPLICABILITY
5	<p>WARNING: IF THE AIRBAG CONTROL MODULE IS DROPPED AT ANY TIME, IT MUST BE REPLACED. FAILURE TO TAKE THE PROPER PRECAUTIONS COULD RESULT IN ACCIDENTAL AIRBAG DEPLOYMENT AND PERSONAL INJURY OR DEATH.</p> <p>If there are no possible causes remaining, view repair.</p> <p>Repair:</p> <ul style="list-style-type: none"> Replace the Airbag Control Module in accordance with Service Information. Perform AIRBAG VERIFICATION TEST - VER 1. 	All
6	<p>With the DRBIII®, record and erase all DTC's from all Airbag modules.</p> <p>If equipped with Passenger Airbag On - Off switch, read the DTC's in all switch positions.</p> <p>If any ACTIVE codes are present they must be resolved before diagnosing any stored codes.</p> <p>WARNING: TO AVOID PERSONAL INJURY OR DEATH, TURN THE IGNITION OFF, DISCONNECT THE BATTERY AND WAIT TWO MINUTES BEFORE PROCEEDING.</p> <p>Using the wiring diagram/schematic as a guide, inspect the wiring and connectors. Look for chaffed, pierced, pinched, or partially broken wires and broken, bent, pushed out, spread, corroded, or contaminated terminals.</p> <p>The following additional checks may assist you in identifying a possible intermittent problem.</p> <p>Reconnect any disconnected components and harness connector.</p> <p>WARNING: TO AVOID PERSONAL INJURY OR DEATH, TURN THE IGNITION ON, THEN RECONNECT THE BATTERY.</p> <p>With the DRBIII® monitor active codes as you work through the following steps.</p> <p>WARNING: TO AVOID PERSONAL INJURY OR DEATH, MAINTAIN A SAFE DISTANCE FROM ALL AIRBAGS WHILE PERFORMING THE FOLLOWING STEPS.</p> <p>Wiggle the wiring harness and connectors of the related airbag circuit or component. If codes are related to the Driver circuits, rotate the steering wheel from stop to stop. You have just attempted to simulate the condition that initially set the trouble code message.</p> <p>Did the DTC become active?</p> <ul style="list-style-type: none"> Yes → Select appropriate symptom from Symptom List. No → No problem found at this time. Erase all codes before returning vehicle to customer. 	All

Symptom:
DRIVER SQUIB 1 CIRCUIT SHORT

When Monitored and Set Condition:

DRIVER SQUIB 1 CIRCUIT SHORT

When Monitored: With the ignition on, the ACM monitors the resistance of the Driver Squib 1 circuits.

Set Condition: The ACM has detected low resistance on the Driver Squib 1 circuits.

POSSIBLE CAUSES

DRIVER AIRBAG SQUIB 1 CIRCUIT SHORT
 CLOCKSPRING, DRIVER SQUIB 1 CIRCUITS SHORT
 DRIVER AIRBAG SQUIB 1 LINE 1 SHORT TO LINE 2
 ACM, DRIVER SQUIB LINE 1 SHORT TO LINE 2
 STORED CODE OR INTERMITTENT CONDITION
 ACTIVE CODE PRESENT

TEST	ACTION	APPLICABILITY
1	Turn the ignition on. NOTE: Ensure the battery is fully charged. NOTE: For the purpose of this test, the AECM and ORC modules will be referred to as an ACM. SELECT ACTIVE or STORED DTC: ACM - ACTIVE DTC Go To 2 ACM - STORED DTC Go To 6 NOTE: When reconnecting airbag system components the Ignition must be turned off and the Battery must be disconnected.	All

DRIVER SQUIB 1 CIRCUIT SHORT — Continued

TEST	ACTION	APPLICABILITY
2	<p>WARNING: TO AVOID PERSONAL INJURY OR DEATH, TURN THE IGNITION OFF, DISCONNECT THE BATTERY AND WAIT TWO MINUTES BEFORE PROCEEDING.</p> <p>Disconnect the Driver Airbag connector(s).</p> <p>NOTE: Check connectors - Clean and repair as necessary.</p> <p>WARNING: TO AVOID PERSONAL INJURY OR DEATH, DO NOT PLACE AN INTACT UNDEPLOYED AIRBAG FACE DOWN ON A HARD SURFACE, THE AIRBAG WILL PROPEL INTO THE AIR IF ACCIDENTALLY DEPLOYED.</p> <p>Connect the appropriate Load Tool to the Driver Airbag connector(s).</p> <p>WARNING: TO AVOID PERSONAL INJURY OR DEATH, TURN THE IGNITION ON, THEN RECONNECT THE BATTERY.</p> <p>With the DRBIII®, read the active Airbag Control Module DTC's.</p> <p>Does the DRBIII® show DRIVER SQUIB 1 CIRCUIT SHORT?</p> <p>Yes → Go To 3</p> <p>No → Replace the Driver Airbag in accordance with the Service Information.</p> <p>Perform AIRBAG VERIFICATION TEST - VER 1.</p>	All
3	<p>WARNING: TO AVOID PERSONAL INJURY OR DEATH, TURN THE IGNITION OFF, DISCONNECT THE BATTERY AND WAIT TWO MINUTES BEFORE PROCEEDING.</p> <p>Disconnect the Load Tool from the Driver Airbag connector(s).</p> <p>Disconnect the Clockspring connector(s).</p> <p>NOTE: Check connectors - Clean and repair as necessary.</p> <p>Connect the appropriate Load Tool to the Clockspring connector(s).</p> <p>WARNING: TO AVOID PERSONAL INJURY OR DEATH, TURN THE IGNITION ON, THEN RECONNECT THE BATTERY.</p> <p>With the DRBIII®, read the active Airbag Control Module DTC's.</p> <p>Does the DRBIII® show DRIVER SQUIB 1 CIRCUIT SHORT?</p> <p>Yes → Go To 4</p> <p>No → Replace the Clockspring in accordance with the Service Information.</p> <p>Perform AIRBAG VERIFICATION TEST - VER 1.</p>	All
4	<p>WARNING: TO AVOID PERSONAL INJURY OR DEATH, TURN THE IGNITION OFF, DISCONNECT THE BATTERY AND WAIT TWO MINUTES BEFORE PROCEEDING.</p> <p>Disconnect the Load Tool from the Clockspring connector(s).</p> <p>Disconnect the Airbag Control Module connector(s).</p> <p>NOTE: Check connectors - Clean and repair as necessary.</p> <p>Connect the appropriate Load Tool Adaptor to the Airbag Control Module connector(s).</p> <p>Measure the resistance between the Driver Squib 1 Line 1 and Line 2 at the Clockspring connector.</p> <p>Is the resistance below 10K ohms?</p> <p>Yes → Repair the Driver Squib 1 Line 1 circuit shorted to Driver Squib 1 Line 2 circuit.</p> <p>Perform AIRBAG VERIFICATION TEST - VER 1.</p> <p>No → Go To 5</p>	All

DRIVER SQUIB 1 CIRCUIT SHORT — Continued

TEST	ACTION	APPLICABILITY
5	<p>WARNING: IF THE AIRBAG CONTROL MODULE IS DROPPED AT ANY TIME, IT MUST BE REPLACED. FAILURE TO TAKE THE PROPER PRECAUTIONS COULD RESULT IN ACCIDENTAL AIRBAG DEPLOYMENT AND PERSONAL INJURY OR DEATH.</p> <p>If there are no possible causes remaining, view repair.</p> <p>Repair:</p> <ul style="list-style-type: none"> Replace the Airbag Control Module in accordance with Service Information. Perform AIRBAG VERIFICATION TEST - VER 1. 	All
6	<p>With the DRBIII®, record and erase all DTC's from all Airbag modules.</p> <p>If equipped with Passenger Airbag On - Off switch, read the DTC's in all switch positions.</p> <p>If any ACTIVE codes are present they must be resolved before diagnosing any stored codes.</p> <p>WARNING: TO AVOID PERSONAL INJURY OR DEATH, TURN THE IGNITION OFF, DISCONNECT THE BATTERY AND WAIT TWO MINUTES BEFORE PROCEEDING.</p> <p>Using the wiring diagram/schematic as a guide, inspect the wiring and connectors. Look for chaffed, pierced, pinched, or partially broken wires and broken, bent, pushed out, spread, corroded, or contaminated terminals.</p> <p>The following additional checks may assist you in identifying a possible intermittent problem.</p> <p>Reconnect any disconnected components and harness connector.</p> <p>WARNING: TO AVOID PERSONAL INJURY OR DEATH, TURN THE IGNITION ON, THEN RECONNECT THE BATTERY.</p> <p>With the DRBIII® monitor active codes as you work through the following steps.</p> <p>WARNING: TO AVOID PERSONAL INJURY OR DEATH, MAINTAIN A SAFE DISTANCE FROM ALL AIRBAGS WHILE PERFORMING THE FOLLOWING STEPS.</p> <p>Wiggle the wiring harness and connectors of the related airbag circuit or component. If codes are related to the Driver circuits, rotate the steering wheel from stop to stop. You have just attempted to simulate the condition that initially set the trouble code message.</p> <p>Did the DTC become active?</p> <ul style="list-style-type: none"> Yes → Select appropriate symptom from Symptom List. No → No problem found at this time. Erase all codes before returning vehicle to customer. 	All

Symptom:
DRIVER SQUIB 1 SHORT TO BATTERY

When Monitored and Set Condition:

DRIVER SQUIB 1 SHORT TO BATTERY

When Monitored: With the ignition on, the ACM monitors the voltage of the Driver Squib 1 circuits.

Set Condition: The ACM has detected high voltage on the Driver Squib 1 circuits.

POSSIBLE CAUSES

DRIVER AIRBAG SQUIB 1 SHORT TO BATTERY
 CLOCKSPRING, DRIVER SQUIB 1 SHORT TO BATTERY
 DRIVER SQUIB 1 LINE 1 OR LINE 2 SHORT TO BATTERY
 ACM, DRIVER SQUIB 1 SHORT TO BATTERY
 STORED CODE OR INTERMITTENT CONDITION
 ACTIVE CODE PRESENT

TEST	ACTION	APPLICABILITY
1	Turn the ignition on. NOTE: Ensure the battery is fully charged. NOTE: For the purpose of this test, the AECM and ORC modules will be referred to as an ACM. SELECT ACTIVE or STORED ACM DTC: ACM - ACTIVE DTC Go To 2 ACM - STORED DTC Go To 5 NOTE: When reconnecting Airbag system components, the ignition must be turned off and the battery must be disconnected.	All

DRIVER SQUIB 1 SHORT TO BATTERY — Continued

TEST	ACTION	APPLICABILITY
2	<p>WARNING: TO AVOID PERSONAL INJURY OR DEATH, TURN THE IGNITION OFF, DISCONNECT THE BATTERY AND WAIT TWO MINUTES BEFORE PROCEEDING.</p> <p>Disconnect the Driver Airbag Squib connector(s).</p> <p>WARNING: TO AVOID PERSONAL INJURY OR DEATH, DO NOT PLACE AN INTACT UNDEPLOYED AIRBAG FACE DOWN ON A HARD SURFACE, THE AIRBAG WILL PROPEL INTO THE AIR IF ACCIDENTALLY DEPLOYED.</p> <p>NOTE: Check connectors - Clean and repair as necessary.</p> <p>Connect the appropriate Load Tool to the Driver Airbag connector(s).</p> <p>WARNING: TO AVOID PERSONAL INJURY OR DEATH, TURN THE IGNITION ON, THEN RECONNECT THE BATTERY.</p> <p>With the DRBIII®, read the active Airbag Control Module DTC's.</p> <p>Does the DRBIII® show DRIVER SQUIB 1 SHORT TO BATTERY?</p> <p>Yes → Go To 3</p> <p>No → Replace the Driver Airbag in accordance with the Service Information.</p> <p>Perform AIRBAG VERIFICATION TEST - VER 1.</p>	All
3	<p>WARNING: TO AVOID PERSONAL INJURY OR DEATH, TURN THE IGNITION OFF, DISCONNECT THE BATTERY AND WAIT TWO MINUTES BEFORE PROCEEDING.</p> <p>Disconnect the Load Tool from the Driver Airbag connector(s).</p> <p>Disconnect the Clockspring connector(s).</p> <p>NOTE: Check connectors - Clean and repair as necessary.</p> <p>Connect the appropriate Load Tool to the Clockspring connector(s).</p> <p>WARNING: TO AVOID PERSONAL INJURY OR DEATH, TURN THE IGNITION ON, THEN RECONNECT THE BATTERY.</p> <p>With the DRBIII®, read the active Airbag Control Module DTC's.</p> <p>Does the DRBIII® show DRIVER SQUIB 1 SHORT TO BATTERY ?</p> <p>Yes → Go To 4</p> <p>No → Replace the Clockspring in accordance with the Service Information.</p> <p>Perform AIRBAG VERIFICATION TEST - VER 1.</p>	All

DRIVER SQUIB 1 SHORT TO BATTERY — Continued

TEST	ACTION	APPLICABILITY
4	<p>WARNING: TO AVOID PERSONAL INJURY OR DEATH, TURN THE IGNITION OFF, DISCONNECT THE BATTERY AND WAIT TWO MINUTES BEFORE PROCEEDING.</p> <p>WARNING: TO AVOID PERSONAL INJURY OR DEATH, IF THE AIRBAG CONTROL MODULE IS DROPPED AT ANY TIME, IT MUST BE REPLACED.</p> <p>Disconnect the Load Tool from the Clockspring connector(s). Disconnect the Airbag Control Module connector(s). NOTE: Check connectors - Clean and repair as necessary. Connect the appropriate Load Tool Adaptor to the Airbag Control Module connector(s).</p> <p>WARNING: TO AVOID PERSONAL INJURY OR DEATH, TURN THE IGNITION ON, THEN RECONNECT THE BATTERY.</p> <p>Measure the voltage on the Driver Squib 1 Line 1 and Line 2 circuits between the Clockspring connector and ground. Is there any voltage present?</p> <p>Yes → Repair the Driver Squib 1 Line 1 or Line 2 circuits shorted to battery. Perform AIRBAG VERIFICATION TEST - VER 1.</p> <p>No → Replace the Airbag Control Module in accordance with Service Information. Perform AIRBAG VERIFICATION TEST - VER 1.</p>	All
5	<p>With the DRBIII®, record and erase all DTC's from all Airbag modules. If equipped with Passenger Airbag On - Off switch, read the DTC's in all switch positions. If any ACTIVE codes are present they must be resolved before diagnosing any stored codes.</p> <p>WARNING: TO AVOID PERSONAL INJURY OR DEATH, TURN THE IGNITION OFF, DISCONNECT THE BATTERY AND WAIT TWO MINUTES BEFORE PROCEEDING.</p> <p>Using the wiring diagram/schematic as a guide, inspect the wiring and connectors. Look for chaffed, pierced, pinched, or partially broken wires and broken, bent, pushed out, spread, corroded, or contaminated terminals. The following additional checks may assist you in identifying a possible intermittent problem. Reconnect any disconnected components and harness connector.</p> <p>WARNING: TO AVOID PERSONAL INJURY OR DEATH, TURN THE IGNITION ON, THEN RECONNECT THE BATTERY.</p> <p>With the DRBIII® monitor active codes as you work through the following steps. WARNING: TO AVOID PERSONAL INJURY OR DEATH, MAINTAIN A SAFE DISTANCE FROM ALL AIRBAGS WHILE PERFORMING THE FOLLOWING STEPS.</p> <p>Wiggle the wiring harness and connectors of the related airbag circuit or component. If codes are related to the Driver circuits, rotate the steering wheel from stop to stop. You have just attempted to simulate the condition that initially set the trouble code message. Did the DTC become active?</p> <p>Yes → Select appropriate symptom from Symptom List.</p> <p>No → No problem found at this time. Erase all codes before returning vehicle to customer.</p>	All

Symptom:

DRIVER SQUIB 1 SHORT TO GROUND

When Monitored and Set Condition:

DRIVER SQUIB 1 SHORT TO GROUND

When Monitored: With the ignition on, the ACM monitors the resistance of the Driver Squib 1 circuits.

Set Condition: When the ACM detects a short to ground in either Driver Squib 1 circuits.

POSSIBLE CAUSES

DRIVER AIRBAG SQUIB 1 SHORT TO GROUND
 CLOCKSPRING, DRIVER SQUIB 1 SHORT TO GROUND
 DRIVER SQUIB 1 LINE 1 OR LINE 2 SHORTED TO GROUND
 ACM, DRIVER SQUIB 1 SHORT TO GROUND
 STORED CODE OR INTERMITTENT CONDITION
 ACTIVE CODE PRESENT

TEST	ACTION	APPLICABILITY
1	Turn the ignition on. NOTE: Ensure the battery is fully charged. NOTE: For the purpose of this test, the AECM and ORC modules will be referred to as an ACM. SELECT ACTIVE or STORED DTC: ACM - ACTIVE DTC Go To 2 ACM - STORED DTC Go To 6 NOTE: When reconnecting Airbag system components, the ignition must be turned off and the battery must be disconnected.	All

DRIVER SQUIB 1 SHORT TO GROUND — Continued

TEST	ACTION	APPLICABILITY
2	<p>WARNING: TO AVOID PERSONAL INJURY OR DEATH, TURN THE IGNITION OFF, DISCONNECT THE BATTERY AND WAIT TWO MINUTES BEFORE PROCEEDING.</p> <p>Disconnect the Driver Airbag Squib connector(s).</p> <p>NOTE: Check connectors - Clean and repair as necessary.</p> <p>WARNING: TO AVOID PERSONAL INJURY OR DEATH, DO NOT PLACE AN INTACT UNDEPLOYED AIRBAG FACE DOWN ON A HARD SURFACE, THE AIRBAG WILL PROPEL INTO THE AIR IF ACCIDENTALLY DEPLOYED.</p> <p>Connect the appropriate Load Tool to the Driver Airbag connector(s).</p> <p>WARNING: TO AVOID PERSONAL INJURY OR DEATH, TURN THE IGNITION ON, THEN RECONNECT THE BATTERY.</p> <p>With the DRBIII®, read the active Airbag Control Module DTC's.</p> <p>Does the DRBIII® show DRIVER SQUIB 1 SHORT TO GROUND?</p> <p>Yes → Go To 3</p> <p>No → Replace the Driver Airbag in accordance with the Service Information.</p> <p>Perform AIRBAG VERIFICATION TEST - VER 1.</p>	All
3	<p>WARNING: TO AVOID PERSONAL INJURY OR DEATH, TURN THE IGNITION OFF, DISCONNECT THE BATTERY AND WAIT TWO MINUTES BEFORE PROCEEDING.</p> <p>Disconnect the Load Tool from the Driver Airbag connector(s).</p> <p>Disconnect the Clockspring connector.</p> <p>NOTE: Check connectors - Clean and repair as necessary.</p> <p>Connect the appropriate Load Tool to the Clockspring connector.</p> <p>WARNING: TO AVOID PERSONAL INJURY OR DEATH, TURN THE IGNITION ON, THEN RECONNECT THE BATTERY.</p> <p>With the DRBIII®, read the active Airbag Control Module DTC's.</p> <p>Does the DRBIII® show DRIVER SQUIB 1 SHORT TO GROUND?</p> <p>Yes → Go To 4</p> <p>No → Replace the Clockspring in accordance with the Service Information.</p> <p>Perform AIRBAG VERIFICATION TEST - VER 1.</p>	All
4	<p>WARNING: TO AVOID PERSONAL INJURY OR DEATH, TURN THE IGNITION OFF, DISCONNECT THE BATTERY AND WAIT TWO MINUTES BEFORE PROCEEDING.</p> <p>Disconnect the Load Tool from the Clockspring connector.</p> <p>Disconnect the Airbag Control Module connector(s).</p> <p>NOTE: Check connectors - Clean and repair as necessary.</p> <p>Connect the appropriate Load Tool Adaptor to the Airbag Control Module connector.</p> <p>Measure the resistance of the Driver Squib 1 Line 1 and Line 2 circuits between Clockspring connector and ground.</p> <p>Is the resistance below 10K ohms on either circuit?</p> <p>Yes → Repair Driver Squib 1 Line 1 or Line 2 circuits shorted to ground.</p> <p>Perform AIRBAG VERIFICATION TEST - VER 1.</p> <p>No → Go To 5</p>	All

DRIVER SQUIB 1 SHORT TO GROUND — Continued

TEST	ACTION	APPLICABILITY
5	<p>WARNING: IF THE AIRBAG CONTROL MODULE IS DROPPED AT ANY TIME, IT MUST BE REPLACED. FAILURE TO TAKE THE PROPER PRECAUTIONS COULD RESULT IN ACCIDENTAL AIRBAG DEPLOYMENT AND PERSONAL INJURY OR DEATH.</p> <p>If there are no possible causes remaining, view repair.</p> <p>Repair:</p> <ul style="list-style-type: none"> Replace the Airbag Control Module in accordance with Service Information. Perform AIRBAG VERIFICATION TEST - VER 1. 	All
6	<p>With the DRBIII®, record and erase all DTC's from all Airbag modules.</p> <p>If equipped with Passenger Airbag On - Off switch, read the DTC's in all switch positions.</p> <p>If any ACTIVE codes are present they must be resolved before diagnosing any stored codes.</p> <p>WARNING: TO AVOID PERSONAL INJURY OR DEATH, TURN THE IGNITION OFF, DISCONNECT THE BATTERY AND WAIT TWO MINUTES BEFORE PROCEEDING.</p> <p>Using the wiring diagram/schematic as a guide, inspect the wiring and connectors. Look for chaffed, pierced, pinched, or partially broken wires and broken, bent, pushed out, spread, corroded, or contaminated terminals.</p> <p>The following additional checks may assist you in identifying a possible intermittent problem.</p> <p>Reconnect any disconnected components and harness connector.</p> <p>WARNING: TO AVOID PERSONAL INJURY OR DEATH, TURN THE IGNITION ON, THEN RECONNECT THE BATTERY.</p> <p>With the DRBIII® monitor active codes as you work through the following steps.</p> <p>WARNING: TO AVOID PERSONAL INJURY OR DEATH, MAINTAIN A SAFE DISTANCE FROM ALL AIRBAGS WHILE PERFORMING THE FOLLOWING STEPS.</p> <p>Wiggle the wiring harness and connectors of the related airbag circuit or component. If codes are related to the Driver circuits, rotate the steering wheel from stop to stop. You have just attempted to simulate the condition that initially set the trouble code message.</p> <p>Did the DTC become active?</p> <ul style="list-style-type: none"> Yes → Select appropriate symptom from Symptom List. No → No problem found at this time. Erase all codes before returning vehicle to customer. 	All

Symptom:
LOSS OF IGNITION RUN - START

When Monitored and Set Condition:

LOSS OF IGNITION RUN - START

When Monitored: With the ignition in the Run-Start position the ACM monitors the Fused Ignition Switch Output Run-Start circuit for proper system voltage.

Set Condition: If the voltage on the Fused Ignition Switch Output Run-Start circuit drops below approximately 6.0 volts, the code will set and all communicate with the DRB will stop. The DRB will report a NO RESPONSE from the ACM.

POSSIBLE CAUSES

ACM, LOSS OF IGNITION RUN - START VOLTAGE
 INTERMITTENT RUN - START CONDITION
 ACTIVE CODE PRESENT

TEST	ACTION	APPLICABILITY
1	Ensure the battery is fully charged. Turn the ignition on. NOTE: For the purpose of this test, the AECM and ORC modules will be referred to as an ACM. DETERMINE ACTIVE OR STORED DTC: ACM - ACTIVE DTC Go To 2 ACM - STORED DTC Go To 3 NOTE: When reconnecting Airbag system components, the ignition must be turned off and the battery must be disconnected.	All
2	WARNING: TO AVOID PERSONAL INJURY OR DEATH, TURN IGNITION OFF, DISCONNECT THE BATTERY AND WAIT TWO MINUTES BEFORE PROCEEDING. WARNING: IF THE AIRBAG CONTROL MODULE IS DROPPED AT ANY TIME, IT MUST BE REPLACED. FAILURE TO TAKE THE PROPER PRECAUTIONS COULD RESULT IN ACCIDENTAL AIRBAG DEPLOYMENT AND PERSONAL INJURY OR DEATH. If there are no possible causes remaining, view repair. Repair: Replace the Airbag Control Module in accordance with Service Instructions. Perform AIRBAG VERIFICATION TEST - VER 1.	All

LOSS OF IGNITION RUN - START — Continued

TEST	ACTION	APPLICABILITY
3	<p>With the DRBIII®, record and erase all DTC's from all Airbag modules. If any ACTIVE codes are present they must be resolved before diagnosing any stored codes.</p> <p>WARNING: TO AVOID PERSONAL INJURY OR DEATH, TURN THE IGNITION OFF, DISCONNECT THE BATTERY AND WAIT TWO MINUTES BEFORE PROCEEDING.</p> <p>Using the wiring diagram/schematic as a guide, inspect the wiring and connectors. Look for chaffed, pierced, pinched, or partially broken wires and broken, bent, pushed out, spread, corroded, or contaminated terminals.</p> <p>Reconnect any disconnected components and harness connector.</p> <p>WARNING: TO AVOID PERSONAL INJURY OR DEATH, TURN THE IGNITION ON, THEN RECONNECT THE BATTERY.</p> <p>With the DRBIII® monitor active codes as you work through the following steps.</p> <p>WARNING: TO AVOID PERSONAL INJURY OR DEATH, MAINTAIN A SAFE DISTANCE FROM ALL AIRBAGS WHILE PERFORMING THE FOLLOWING STEPS.</p> <p>Wiggle the wiring harness and connectors of the related Run - Start circuit.</p> <p>Is there any active DTC's present?</p> <p style="padding-left: 40px;">Yes → Select appropriate symptom from Symptom List. Perform AIRBAG VERIFICATION TEST - VER 1.</p> <p style="padding-left: 40px;">No → No problem found at this time. Erase all codes before returning vehicle to customer. Perform AIRBAG VERIFICATION TEST - VER 1.</p>	All

Symptom:

PASSENGER SEAT BELT TENSIONER CIRCUIT OPEN

When Monitored and Set Condition:

PASSENGER SEAT BELT TENSIONER CIRCUIT OPEN

When Monitored: With the ignition on, the ACM monitors the resistance of the Passenger Seat Belt Tensioner circuits.

Set Condition: When the ACM detects an open circuit or high resistance in the Passenger Seat Belt Tensioner circuits.

POSSIBLE CAUSES

PASSENGER SEAT BELT TENSIONER CIRCUIT OPEN
 PASSENGER SEAT BELT TENSIONER LINE 1 OR LINE 2 CIRCUIT OPEN
 ACM, PASSENGER SEAT BELT TENSIONER CIRCUIT OPEN
 STORED CODE OR INTERMITTENT CONDITION
 ACTIVE CODE PRESENT

TEST	ACTION	APPLICABILITY
<p>1</p>	<p>Turn the ignition on. NOTE: Ensure the battery is fully charged. NOTE: For the purpose of this test, the AECM and ORC modules will be referred to as an ACM. SELECT ACTIVE or STORED DTC:</p> <p style="padding-left: 40px;">ACM - ACTIVE DTC Go To 2</p> <p style="padding-left: 40px;">ACM - STORED DTC Go To 5</p> <p>NOTE: When reconnecting Airbag system components, the ignition must be turned off and the battery must be disconnected.</p>	<p>All</p>
<p>2</p>	<p>WARNING: TO AVOID PERSONAL INJURY OR DEATH, TURN IGNITION OFF, DISCONNECT THE BATTERY AND WAIT TWO MINUTES BEFORE PROCEEDING. Disconnect the Passenger Seat Belt Tensioner connector. NOTE: Check connectors - Clean and repair as necessary. Connect the appropriate Load Tool to the Passenger Seat Belt Tensioner connector. WARNING: TO AVOID PERSONAL INJURY OR DEATH, TURN IGNITION ON, THEN RECONNECT THE BATTERY. With the DRBIII®, read the active Airbag Control Module DTC's. Does the DRBIII® display PASSENGER SBT CIRCUIT OPEN?</p> <p style="padding-left: 40px;">Yes → Go To 3</p> <p style="padding-left: 40px;">No → Replace the Passenger Seat Belt Tensioner in accordance with the Service Information. Perform AIRBAG VERIFICATION TEST - VER 1.</p>	<p>All</p>

PASSENGER SEAT BELT TENSIONER CIRCUIT OPEN — Continued

TEST	ACTION	APPLICABILITY
3	<p>WARNING: TO AVOID PERSONAL INJURY OR DEATH, TURN IGNITION OFF, DISCONNECT THE BATTERY AND WAIT TWO MINUTES BEFORE PROCEEDING.</p> <p>Disconnect the Load Tool from the Passenger SBT connector. Disconnect the Airbag control Module connector(s). NOTE: Check connectors - Clean and repair as necessary. Connect the appropriate Load Tool ACM Adaptor to the Airbag Control Module connector. Measure the resistance of the Passenger Seat Belt Tensioner Line 1 and Line 2 circuits between the Load Tool Adaptor and the Passenger SBT connector. Is the resistance below 1.0 ohms on either circuit ?</p> <p>Yes → Go To 4</p> <p>No → Repair open or high resistance in Passenger Seat Belt Tensioner Line 1 or Line 2 circuits. Perform AIRBAG VERIFICATION TEST - VER 1.</p>	All
4	<p>WARNING: IF THE AIRBAG CONTROL MODULE IS DROPPED AT ANY TIME, IT MUST BE REPLACED. FAILURE TO TAKE THE PROPER PRECAUTIONS COULD RESULT IN ACCIDENTAL AIRBAG DEPLOYMENT AND PERSONAL INJURY OR DEATH.</p> <p>If there are no possible causes remaining, view repair.</p> <p>Repair: Replace the Airbag Control Module in accordance with the Service information. Perform AIRBAG VERIFICATION TEST - VER 1.</p>	All
5	<p>With the DRBIII®, record and erase all DTC's from all Airbag modules. If equipped with Passenger Airbag On - Off switch, read the DTC's in all switch positions. If any ACTIVE codes are present they must be resolved before diagnosing any stored codes.</p> <p>WARNING: TO AVOID PERSONAL INJURY OR DEATH, TURN THE IGNITION OFF, DISCONNECT THE BATTERY AND WAIT TWO MINUTES BEFORE PROCEEDING.</p> <p>Using the wiring diagram/schematic as a guide, inspect the wiring and connectors. Look for chaffed, pierced, pinched, or partially broken wires and broken, bent, pushed out, spread, corroded, or contaminated terminals. The following additional checks may assist you in identifying a possible intermittent problem. Reconnect any disconnected components and harness connector.</p> <p>WARNING: TO AVOID PERSONAL INJURY OR DEATH, TURN THE IGNITION ON, THEN RECONNECT THE BATTERY.</p> <p>With the DRBIII® monitor active codes as you work through the following steps. WARNING: TO AVOID PERSONAL INJURY OR DEATH, MAINTAIN A SAFE DISTANCE FROM ALL AIRBAGS WHILE PERFORMING THE FOLLOWING STEPS.</p> <p>Wiggle the wiring harness and connectors of the related airbag circuit or component. If codes are related to the Driver circuits, rotate the steering wheel from stop to stop. You have just attempted to simulate the condition that initially set the trouble code message. Did the DTC become active?</p> <p>Yes → Select appropriate symptom from Symptom List.</p> <p>No → No problem found at this time. Erase all codes before returning vehicle to customer.</p>	All

Symptom:

PASSENGER SEAT BELT TENSIONER CIRCUIT SHORT

When Monitored and Set Condition:

PASSENGER SEAT BELT TENSIONER CIRCUIT SHORT

When Monitored: With the ignition on, the ACM monitors the resistance between the Passenger Seat Belt Tensioner circuits.

Set Condition: When the ACM detects low resistance in the Passenger Seat Belt Tensioner circuits.

POSSIBLE CAUSES

PASSENGER SEAT BELT TENSIONER LINE 1 SHORT TO LINE 2
 PASSENGER SEAT BELT TENSIONER CIRCUIT SHORT
 ACM, PASSENGER SEAT BELT TENSIONER CIRCUIT SHORT
 STORED CODE OR INTERMITTENT CONDITION
 ACTIVE CODE PRESENT

TEST	ACTION	APPLICABILITY
1	Turn the ignition on. NOTE: Ensure the battery is fully charged. NOTE: For the purpose of this test, the AECM and ORC modules will be referred to as an ACM. SELECT ACTIVE or STORED DTC: ACM - ACTIVE DTC Go To 2 ACM - STORED DTC Go To 5 NOTE: When reconnecting Airbag system components, the ignition must be turned off and the battery must be disconnected.	All
2	WARNING: TO AVOID PERSONAL INJURY OR DEATH, TURN IGNITION OFF, DISCONNECT THE BATTERY AND WAIT TWO MINUTES BEFORE PROCEEDING. Disconnect the Passenger Seat Belt Tensioner connector. NOTE: Check connectors - Clean and repair as necessary. Connect the appropriate Load Tool to the Passenger Seat Belt Tensioner connector. WARNING: TO AVOID PERSONAL INJURY OR DEATH, TURN IGNITION ON, THEN RECONNECT THE BATTERY. With the DRBIII®, read the active Airbag Control Module DTC's. Does the DRBIII® show PASSENGER SEAT BELT TENSIONER CIRCUIT SHORT? Yes → Go To 3 No → Replace the Passenger Seat Belt Tensioner in accordance with the Service Information. Perform AIRBAG VERIFICATION TEST - VER 1.	All

PASSENGER SEAT BELT TENSIONER CIRCUIT SHORT — Continued

TEST	ACTION	APPLICABILITY
3	<p>WARNING: TO AVOID PERSONAL INJURY OR DEATH, TURN IGNITION OFF, DISCONNECT THE BATTERY AND WAIT TWO MINUTES BEFORE PROCEEDING.</p> <p>Disconnect the Load Tool from the Passenger Seat Belt Tensioner connector. Disconnect the Airbag Control Module connector(s). NOTE: Check connectors - Clean and repair as necessary. Connect the appropriate Load Tool ACM Adaptor to the Airbag Control Module connector(s). Measure the resistance between the Passenger SBT Line 1 and line 2 circuit at the Passenger Seat Belt Tensioner connector. Is the resistance below 10K ohms?</p> <p>Yes → Repair the Passenger Seat Belt Tensioner Line 1 short to Line 2 circuit. Perform AIRBAG VERIFICATION TEST - VER 1.</p> <p>No → Go To 4</p>	All
4	<p>WARNING: IF THE AIRBAG CONTROL MODULE IS DROPPED AT ANY TIME, IT MUST BE REPLACED. FAILURE TO TAKE THE PROPER PRECAUTIONS COULD RESULT IN ACCIDENTAL AIRBAG DEPLOYMENT AND PERSONAL INJURY OR DEATH.</p> <p>If there are no possible causes remaining, view repair.</p> <p>Repair: Replace the Airbag Control Module in accordance with the Service Information. Perform AIRBAG VERIFICATION TEST - VER 1.</p>	All
5	<p>With the DRBIII®, record and erase all DTC's from all Airbag modules. If equipped with Passenger Airbag On - Off switch, read the DTC's in all switch positions. If any ACTIVE codes are present they must be resolved before diagnosing any stored codes.</p> <p>WARNING: TO AVOID PERSONAL INJURY OR DEATH, TURN THE IGNITION OFF, DISCONNECT THE BATTERY AND WAIT TWO MINUTES BEFORE PROCEEDING.</p> <p>Using the wiring diagram/schematic as a guide, inspect the wiring and connectors. Look for chaffed, pierced, pinched, or partially broken wires and broken, bent, pushed out, spread, corroded, or contaminated terminals. The following additional checks may assist you in identifying a possible intermittent problem. Reconnect any disconnected components and harness connector.</p> <p>WARNING: TO AVOID PERSONAL INJURY OR DEATH, TURN THE IGNITION ON, THEN RECONNECT THE BATTERY.</p> <p>With the DRBIII® monitor active codes as you work through the following steps. WARNING: TO AVOID PERSONAL INJURY OR DEATH, MAINTAIN A SAFE DISTANCE FROM ALL AIRBAGS WHILE PERFORMING THE FOLLOWING STEPS.</p> <p>Wiggle the wiring harness and connectors of the related airbag circuit or component. If codes are related to the Driver circuits, rotate the steering wheel from stop to stop. You have just attempted to simulate the condition that initially set the trouble code message. Did the DTC become active?</p> <p>Yes → Select appropriate symptom from Symptom List.</p> <p>No → No problem found at this time. Erase all codes before returning vehicle to customer.</p>	All

Symptom:

PASSENGER SEAT BELT TENSIONER SHORT TO BATTERY

When Monitored and Set Condition:

PASSENGER SEAT BELT TENSIONER SHORT TO BATTERY

When Monitored: When the ignition is on, the ACM monitors the voltage of the Passenger Seat Belt Tensioner circuits.

Set Condition: When the ACM detects voltage on the Passenger Seat Belt Tensioner circuits.

POSSIBLE CAUSES

- PASSENGER SEAT BELT TENSIONER SHORT TO BATTERY
- PASSENGER SEAT BELT TENSIONER LINE 1 OR LINE 2 SHORT TO BATTERY
- ACM, PASSENGER SBT SHORT TO BATTERY
- STORED CODE OR INTERMITTENT CONDITION
- ACTIVE CODE PRESENT

TEST	ACTION	APPLICABILITY
1	Turn the ignition on. NOTE: Ensure the battery is fully charged. NOTE: For the purpose of this test, the AECM and ORC modules will be referred to as an ACM. SELECT ACTIVE or STORED DTC: ACM - ACTIVE DTC Go To 2 ACM - STORED DTC Go To 5 NOTE: When reconnecting Airbag system components, the ignition must be turned off and the battery must be disconnected.	All
2	WARNING: TO AVOID PERSONAL INJURY OR DEATH, TURN IGNITION OFF, DISCONNECT THE BATTERY AND WAIT TWO MINUTES BEFORE PROCEEDING. Disconnect the Passenger Seat Belt Tensioner connector. NOTE: Check connectors - Clean and repair as necessary. Connect the appropriate Load Tool to the Passenger Seat Belt Tensioner connector. WARNING: TO AVOID PERSONAL INJURY OR DEATH, TURN IGNITION ON, THEN RECONNECT THE BATTERY. With the DRBIII®, read the active Airbag Control Module DTC's. Does the DRBIII® display PASSENGER SBT SHORT TO BATTERY? Yes → Go To 3 No → Replace the Passenger Seat Belt Tensioner in accordance with the Service Information. Perform AIRBAG VERIFICATION TEST - VER 1.	All

PASSENGER SEAT BELT TENSIONER SHORT TO BATTERY — Continued

TEST	ACTION	APPLICABILITY
3	<p>WARNING: TO AVOID PERSONAL INJURY OR DEATH, TURN IGNITION OFF, DISCONNECT THE BATTERY AND WAIT TWO MINUTES BEFORE PROCEEDING.</p> <p>Disconnect the Load Tool from the Passenger Seat Belt Tensioner connector. Disconnect the Airbag Control Module Connector(s). NOTE: Check connectors - Clean and repair as necessary. Connect the appropriate Load Tool ACM Adaptor to the Airbag Control Module connector(s). WARNING: TO AVOID PERSONAL INJURY OR DEATH, TURN IGNITION ON, THEN RECONNECT THE BATTERY.</p> <p>Measure the voltage of the Passenger SBT Line 1 and Line 2 circuits between the Passenger Seat Belt Tensioner connector and ground. Is there any voltage on either circuit?</p> <p style="padding-left: 40px;">Yes → Repair the Passenger Seat Belt Tensioner Line 1 or Line 2 short to battery. Perform AIRBAG VERIFICATION TEST - VER 1.</p> <p style="padding-left: 40px;">No → Go To 4</p>	All
4	<p>WARNING: IF THE AIRBAG CONTROL MODULE IS DROPPED AT ANY TIME, IT MUST BE REPLACED. FAILURE TO TAKE THE PROPER PRECAUTIONS COULD RESULT IN ACCIDENTAL AIRBAG DEPLOYMENT AND PERSONAL INJURY OR DEATH.</p> <p>If there are no possible causes remaining, view repair.</p> <p style="padding-left: 40px;">Repair: Replace the Airbag Control Module in accordance with the Service Information. Perform AIRBAG VERIFICATION TEST - VER 1.</p>	All

PASSENGER SEAT BELT TENSIONER SHORT TO BATTERY — Continued

TEST	ACTION	APPLICABILITY
5	<p>With the DRBIII®, record and erase all DTC's from all Airbag modules.</p> <p>If equipped with Passenger Airbag On - Off switch, read the DTC's in all switch positions.</p> <p>If any ACTIVE codes are present they must be resolved before diagnosing any stored codes.</p> <p>WARNING: TO AVOID PERSONAL INJURY OR DEATH, TURN THE IGNITION OFF, DISCONNECT THE BATTERY AND WAIT TWO MINUTES BEFORE PROCEEDING.</p> <p>Using the wiring diagram/schematic as a guide, inspect the wiring and connectors. Look for chaffed, pierced, pinched, or partially broken wires and broken, bent, pushed out, spread, corroded, or contaminated terminals.</p> <p>The following additional checks may assist you in identifying a possible intermittent problem.</p> <p>Reconnect any disconnected components and harness connector.</p> <p>WARNING: TO AVOID PERSONAL INJURY OR DEATH, TURN THE IGNITION ON, THEN RECONNECT THE BATTERY.</p> <p>With the DRBIII® monitor active codes as you work through the following steps.</p> <p>WARNING: TO AVOID PERSONAL INJURY OR DEATH, MAINTAIN A SAFE DISTANCE FROM ALL AIRBAGS WHILE PERFORMING THE FOLLOWING STEPS.</p> <p>Wiggle the wiring harness and connectors of the related airbag circuit or component. If codes are related to the Driver circuits, rotate the steering wheel from stop to stop. You have just attempted to simulate the condition that initially set the trouble code message.</p> <p>Did the DTC become active?</p> <p>Yes → Select appropriate symptom from Symptom List.</p> <p>No → No problem found at this time. Erase all codes before returning vehicle to customer.</p>	All

Symptom:

PASSENGER SEAT BELT TENSIONER SHORT TO GROUND

When Monitored and Set Condition:

PASSENGER SEAT BELT TENSIONER SHORT TO GROUND

When Monitored: With the ignition on, the ACM monitors the resistance of the Passenger Seat Belt Tensioner circuits.

Set Condition: When the ACM detects a short to ground in either Passenger Seat Belt Tensioner circuits.

POSSIBLE CAUSES
PASSENGER SEAT BELT TENSIONER SHORT TO GROUND PASSENGER SEAT BELT TENSIONER LINE 1 OR LINE 2 SHORTED TO GROUND ACM, PASSENGER SBT SHORT TO GROUND STORED CODE OR INTERMITTENT CONDITION ACTIVE CODE PRESENT

TEST	ACTION	APPLICABILITY
1	Turn the ignition on. NOTE: Ensure the battery is fully charged. NOTE: For the purpose of this test, the AECM and ORC modules will be referred to as an ACM. SELECT ACTIVE or STORED DTC: ACM - ACTIVE DTC Go To 2 ACM - STORED DTC Go To 5 NOTE: When reconnecting Airbag system components, the ignition must be turned off and the battery must be disconnected.	All
2	WARNING: TO AVOID PERSONAL INJURY OR DEATH, TURN IGNITION OFF, DISCONNECT THE BATTERY AND WAIT TWO MINUTES BEFORE PROCEEDING. Disconnect the Passenger Seat Belt Tensioner connector. NOTE: Check connectors - Clean and repair as necessary. Connect the appropriate Load Tool to the Passenger Seat Belt Tensioner connector. WARNING: TO AVOID PERSONAL INJURY OR DEATH, TURN IGNITION ON, THEN RECONNECT THE BATTERY. With the DRBIII®, read the active Airbag Control Module DTC's. Does the DRBIII® display PASSENGER SBT SHORT TO GROUND? Yes → Go To 3 No → Replace the Passenger Seat Belt Tensioner in accordance with the Service Information. Perform AIRBAG VERIFICATION TEST - VER 1.	All

PASSENGER SEAT BELT TENSIONER SHORT TO GROUND — Continued

TEST	ACTION	APPLICABILITY
3	<p>WARNING: TO AVOID PERSONAL INJURY OR DEATH, TURN IGNITION OFF, DISCONNECT THE BATTERY AND WAIT TWO MINUTES BEFORE PROCEEDING.</p> <p>Disconnect the Load Tool from the Passenger Seat Belt Tensioner connector. Disconnect the Airbag Control Module Connector(s). NOTE: Check connectors - Clean and repair as necessary. Connect the appropriate Load Tool ACM Adaptor to the Airbag Control Module connector(s). Measure the resistance of the Passenger Seat Belt Tensioner Line 1 and Line 2 circuits between the Passenger SBT connector and ground. Is the resistance below 10K Ohms on either circuit?</p> <p>Yes → Repair the Passenger Seat Belt Tensioner Line 1 or Line 2 short to ground. Perform AIRBAG VERIFICATION TEST - VER 1.</p> <p>No → Go To 4</p>	All
4	<p>WARNING: IF THE AIRBAG CONTROL MODULE IS DROPPED AT ANY TIME, IT MUST BE REPLACED. FAILURE TO TAKE THE PROPER PRECAUTIONS COULD RESULT IN ACCIDENTAL AIRBAG DEPLOYMENT AND PERSONAL INJURY OR DEATH.</p> <p>If there are no possible causes remaining, view repair.</p> <p>Repair: Replace the Airbag Control Module in accordance with the Service Information. Perform AIRBAG VERIFICATION TEST - VER 1.</p>	All
5	<p>With the DRBIII®, record and erase all DTC's from all Airbag modules. If equipped with Passenger Airbag On - Off switch, read the DTC's in all switch positions. If any ACTIVE codes are present they must be resolved before diagnosing any stored codes.</p> <p>WARNING: TO AVOID PERSONAL INJURY OR DEATH, TURN THE IGNITION OFF, DISCONNECT THE BATTERY AND WAIT TWO MINUTES BEFORE PROCEEDING.</p> <p>Using the wiring diagram/schematic as a guide, inspect the wiring and connectors. Look for chaffed, pierced, pinched, or partially broken wires and broken, bent, pushed out, spread, corroded, or contaminated terminals. The following additional checks may assist you in identifying a possible intermittent problem. Reconnect any disconnected components and harness connector.</p> <p>WARNING: TO AVOID PERSONAL INJURY OR DEATH, TURN THE IGNITION ON, THEN RECONNECT THE BATTERY.</p> <p>With the DRBIII® monitor active codes as you work through the following steps. WARNING: TO AVOID PERSONAL INJURY OR DEATH, MAINTAIN A SAFE DISTANCE FROM ALL AIRBAGS WHILE PERFORMING THE FOLLOWING STEPS.</p> <p>Wiggle the wiring harness and connectors of the related airbag circuit or component. If codes are related to the Driver circuits, rotate the steering wheel from stop to stop. You have just attempted to simulate the condition that initially set the trouble code message. Did the DTC become active?</p> <p>Yes → Select appropriate symptom from Symptom List.</p> <p>No → No problem found at this time. Erase all codes before returning vehicle to customer.</p>	All

Symptom:
PASSENGER SQUIB 1 CIRCUIT OPEN

When Monitored and Set Condition:

PASSENGER SQUIB 1 CIRCUIT OPEN

When Monitored: With the ignition on, the ACM monitors the resistance of the Passenger Squib 1 circuits.

Set Condition: When the ACM detects an open circuit or high resistance on the Passenger Squib 1 circuits.

POSSIBLE CAUSES

PAB SQUIB 1 CIRCUIT OPEN
 PAB SQUIB 1 LINE 1 OR LINE 2 CIRCUIT OPEN
 ACM, PAB SQUIB 1 CIRCUIT OPEN
 STORED CODE OR INTERMITTENT CONDITION
 ACTIVE CODE PRESENT

TEST	ACTION	APPLICABILITY
1	Turn the ignition on. NOTE: Ensure the battery is fully charged. NOTE: For the purpose of this test, the AECM and ORC modules will be referred to as an ACM. SELECT ACTIVE or STORED DTC: ACM - ACTIVE DTC Go To 2 ACM - STORED DTC Go To 5 NOTE: When reconnecting Airbag system components, the ignition must be turned off and the battery must be disconnected.	All

PASSENGER SQUIB 1 CIRCUIT OPEN — Continued

TEST	ACTION	APPLICABILITY
2	<p>WARNING: TO AVOID PERSONAL INJURY OR DEATH, TURN THE IGNITION OFF, DISCONNECT THE BATTERY AND WAIT TWO MINUTES BEFORE PROCEEDING.</p> <p>Disconnect the Passenger Airbag connector(s).</p> <p>NOTE: Check connectors - Clean and repair as necessary.</p> <p>WARNING: TO AVOID PERSONAL INJURY OR DEATH, DO NOT PLACE AN INTACT UNDEPLOYED AIRBAG FACE DOWN ON A HARD SURFACE, THE AIRBAG WILL PROPEL INTO THE AIR IF ACCIDENTALLY DEPLOYED.</p> <p>Connect the Load Tool to the Passenger Airbag connector(s).</p> <p>WARNING: TO AVOID PERSONAL INJURY OR DEATH, TURN IGNITION ON, THEN RECONNECT THE BATTERY.</p> <p>With the DRBIII®, read the active Airbag Control Module DTC's. Does the DRBIII® show PASSENGER SQUIB 1 CIRCUIT OPEN?</p> <p>Yes → Go To 3</p> <p>No → Replace the Passenger Airbag in accordance with the Service Information. Perform AIRBAG VERIFICATION TEST - VER 1.</p>	All
3	<p>WARNING: TO AVOID PERSONAL INJURY OR DEATH, TURN THE IGNITION OFF, DISCONNECT THE BATTERY AND WAIT TWO MINUTES BEFORE PROCEEDING.</p> <p>Disconnect the Load Tool from the Passenger Airbag connector(s).</p> <p>Disconnect the Airbag Control module connector(s).</p> <p>NOTE: Check connectors - Clean and repair as necessary.</p> <p>Connect the Load Tool ACM Adaptor to the Airbag Control Module connector(s).</p> <p>Measure the resistance of the Passenger Squib 1 Line 1 and Line 2 circuit between the ACM Adaptor and the Passenger Airbag connector.</p> <p>Is the resistance below 1.0 ohms on both circuits?</p> <p>Yes → Go To 4</p> <p>No → Repair open or high resistance in Passenger Squib 1 Line 1 or Line 2 circuits. Perform AIRBAG VERIFICATION TEST - VER 1.</p>	All
4	<p>WARNING: IF THE AIRBAG CONTROL MODULE IS DROPPED AT ANY TIME, IT MUST BE REPLACED. FAILURE TO TAKE THE PROPER PRECAUTIONS COULD RESULT IN ACCIDENTAL AIRBAG DEPLOYMENT AND PERSONAL INJURY OR DEATH.</p> <p>If there are no possible causes remaining, view repair.</p> <p>Repair:</p> <p>Replace the Airbag Control Module in accordance with Service Instructions. Perform AIRBAG VERIFICATION TEST - VER 1.</p>	All

PASSENGER SQUIB 1 CIRCUIT OPEN — Continued

TEST	ACTION	APPLICABILITY
5	<p>With the DRBIII®, record and erase all DTC's from all Airbag modules. If equipped with Passenger Airbag On - Off switch, read the DTC's in all switch positions. If any ACTIVE codes are present they must be resolved before diagnosing any stored codes. WARNING: TO AVOID PERSONAL INJURY OR DEATH, TURN THE IGNITION OFF, DISCONNECT THE BATTERY AND WAIT TWO MINUTES BEFORE PROCEEDING. Using the wiring diagram/schematic as a guide, inspect the wiring and connectors. Look for chaffed, pierced, pinched, or partially broken wires and broken, bent, pushed out, spread, corroded, or contaminated terminals. The following additional checks may assist you in identifying a possible intermittent problem. Reconnect any disconnected components and harness connector. WARNING: TO AVOID PERSONAL INJURY OR DEATH, TURN THE IGNITION ON, THEN RECONNECT THE BATTERY. With the DRBIII® monitor active codes as you work through the following steps. WARNING: TO AVOID PERSONAL INJURY OR DEATH, MAINTAIN A SAFE DISTANCE FROM ALL AIRBAGS WHILE PERFORMING THE FOLLOWING STEPS. Wiggle the wiring harness and connectors of the related airbag circuit or component. If codes are related to the Driver circuits, rotate the steering wheel from stop to stop. You have just attempted to simulate the condition that initially set the trouble code message. Did the DTC become active?</p> <p style="padding-left: 40px;">Yes → Select appropriate symptom from Symptom List.</p> <p style="padding-left: 40px;">No → No problem found at this time. Erase all codes before returning vehicle to customer.</p>	All

Symptom:
PASSENGER SQUIB 1 CIRCUIT SHORT

When Monitored and Set Condition:

PASSENGER SQUIB 1 CIRCUIT SHORT

When Monitored: With the ignition on, the ACM monitors the resistance between the Passenger Squib 1 circuits.

Set Condition: When the ACM detects low resistance in the Passenger Squib 1 circuits.

POSSIBLE CAUSES

PAB SQUIB 1 CIRCUIT SHORT
 PAB SQUIB 1 LINE 1 SHORT TO LINE 2
 ACM, PAB SQUIB 1 CIRCUIT SHORT
 STORED CODE OR INTERMITTENT CONDITION
 ACTIVE CODE PRESENT

TEST	ACTION	APPLICABILITY
1	Turn the ignition on. NOTE: Ensure the battery is fully charged. NOTE: For the purpose of this test, the AECM and ORC modules will be referred to as an ACM. SELECT ACTIVE or STORED DTC: ACM - ACTIVE DTC Go To 2 ACM - STORED DTC Go To 5 NOTE: When reconnecting Airbag system components, the ignition must be turned off and the battery must be disconnected.	All

PASSENGER SQUIB 1 CIRCUIT SHORT — Continued

TEST	ACTION	APPLICABILITY
2	<p>WARNING: TO AVOID PERSONAL INJURY OR DEATH, TURN THE IGNITION OFF, DISCONNECT THE BATTERY AND WAIT TWO MINUTES BEFORE PROCEEDING.</p> <p>Disconnect the Passenger Airbag connector(s).</p> <p>NOTE: Check connectors - Clean and repair as necessary.</p> <p>WARNING: TO AVOID PERSONAL INJURY OR DEATH, DO NOT PLACE AN INTACT UNDEPLOYED AIRBAG FACE DOWN ON A HARD SURFACE, THE AIRBAG WILL PROPEL INTO THE AIR IF ACCIDENTALLY DEPLOYED.</p> <p>Connect the appropriate Load Tool to the Passenger Airbag connector(s).</p> <p>WARNING: TO AVOID PERSONAL INJURY OR DEATH, TURN THE IGNITION ON, THEN RECONNECT THE BATTERY.</p> <p>With the DRBIII®, read the active Airbag Control Module DTC's.</p> <p>Does the DRBIII® show PASSENGER SQUIB 1 CIRCUIT SHORT?</p> <p>Yes → Go To 3</p> <p>No → Replace the Passenger Airbag in accordance with the Service Information. Perform AIRBAG VERIFICATION TEST - VER 1.</p>	All
3	<p>WARNING: TO AVOID PERSONAL INJURY OR DEATH, TURN THE IGNITION OFF, DISCONNECT THE BATTERY AND WAIT TWO MINUTES BEFORE PROCEEDING.</p> <p>Disconnect the Load Tool from the Passenger Airbag connector(s).</p> <p>Disconnect the Airbag Control Module connector(s).</p> <p>NOTE: Check connectors - Clean and repair as necessary.</p> <p>Connect the appropriate Load Tool Adapter to the Airbag Control Module connector(s).</p> <p>Measure the resistance between Passenger Squib 1 Line 1 and Line 2 circuits at the Passenger Airbag connector.</p> <p>Is the resistance below 10K ohms?</p> <p>Yes → Repair Passenger Squib 1 Line 1 circuit short to Passenger Squib 1 Line 2 circuit. Perform AIRBAG VERIFICATION TEST - VER 1.</p> <p>No → Go To 4</p>	All
4	<p>WARNING: IF THE AIRBAG CONTROL MODULE IS DROPPED AT ANY TIME, IT MUST BE REPLACED. FAILURE TO TAKE THE PROPER PRECAUTIONS COULD RESULT IN ACCIDENTAL AIRBAG DEPLOYMENT AND PERSONAL INJURY OR DEATH.</p> <p>If there are no possible causes remaining, view repair.</p> <p>Repair:</p> <p>Replace the Airbag Control Module in accordance with Service Information. Perform AIRBAG VERIFICATION TEST - VER 1.</p>	All

PASSENGER SQUIB 1 CIRCUIT SHORT — Continued

TEST	ACTION	APPLICABILITY
5	<p>With the DRBIII®, record and erase all DTC's from all Airbag modules.</p> <p>If equipped with Passenger Airbag On - Off switch, read the DTC's in all switch positions.</p> <p>If any ACTIVE codes are present they must be resolved before diagnosing any stored codes.</p> <p>WARNING: TO AVOID PERSONAL INJURY OR DEATH, TURN THE IGNITION OFF, DISCONNECT THE BATTERY AND WAIT TWO MINUTES BEFORE PROCEEDING.</p> <p>Using the wiring diagram/schematic as a guide, inspect the wiring and connectors. Look for chaffed, pierced, pinched, or partially broken wires and broken, bent, pushed out, spread, corroded, or contaminated terminals.</p> <p>The following additional checks may assist you in identifying a possible intermittent problem.</p> <p>Reconnect any disconnected components and harness connector.</p> <p>WARNING: TO AVOID PERSONAL INJURY OR DEATH, TURN THE IGNITION ON, THEN RECONNECT THE BATTERY.</p> <p>With the DRBIII® monitor active codes as you work through the following steps.</p> <p>WARNING: TO AVOID PERSONAL INJURY OR DEATH, MAINTAIN A SAFE DISTANCE FROM ALL AIRBAGS WHILE PERFORMING THE FOLLOWING STEPS.</p> <p>Wiggle the wiring harness and connectors of the related airbag circuit or component. If codes are related to the Driver circuits, rotate the steering wheel from stop to stop. You have just attempted to simulate the condition that initially set the trouble code message.</p> <p>Did the DTC become active?</p> <p>Yes → Select appropriate symptom from Symptom List.</p> <p>No → No problem found at this time. Erase all codes before returning vehicle to customer.</p>	All

Symptom:

PASSENGER SQUIB 1 SHORT TO BATTERY

When Monitored and Set Condition:

PASSENGER SQUIB 1 SHORT TO BATTERY

When Monitored: With the ignition on, the ACM monitors the voltage on the Passenger Squib 1 circuits.

Set Condition: When the ACM detects voltage on the Passenger Squib 1 circuits.

POSSIBLE CAUSES

- PAB SQUIB 1 CIRCUITS SHORT TO BATTERY
- PAB SQUIB 1 LINE 1 OR LINE 2 SHORT TO BATTERY
- ACM, PAB SQUIB 1 CIRCUIT SHORT TO BATTERY
- STORED CODE OR INTERMITTENT CONDITION
- ACTIVE CODE PRESENT

TEST	ACTION	APPLICABILITY
1	Turn the ignition on. NOTE: Ensure the battery is fully charged. NOTE: For the purpose of this test, the AECM and ORC modules will be referred to as an ACM. SELECT ACTIVE or STORED DTC: ACM - ACTIVE DTC Go To 2 ACM - STORED DTC Go To 5 NOTE: When reconnecting Airbag system components, the ignition must be turned off and the battery must be disconnected.	All

PASSENGER SQUIB 1 SHORT TO BATTERY — Continued

TEST	ACTION	APPLICABILITY
2	<p>WARNING: TO AVOID PERSONAL INJURY OR DEATH, DISCONNECT THE BATTERY AND WAIT TWO MINUTES BEFORE PROCEEDING. Disconnect the Passenger Airbag connector(s).</p> <p>NOTE: Check connectors - Clean and repair as necessary.</p> <p>WARNING: IF THE AIRBAG CONTROL MODULE IS DROPPED AT ANY TIME, IT MUST BE REPLACED. FAILURE TO TAKE THE PROPER PRECAUTIONS COULD RESULT IN ACCIDENTAL AIRBAG DEPLOYMENT AND PERSONAL INJURY OR DEATH.</p> <p>Connect the appropriate Load Tool to the Passenger Airbag connector(s).</p> <p>WARNING: TO AVOID PERSONAL INJURY OR DEATH, THE IGNITION ON, THEN RECONNECT THE BATTERY.</p> <p>With the DRBIII®, read the active Airbag Control Module DTC's. Does the DRBIII® show PASSENGER SQUIB 1 CIRCUIT SHORT TO BATTERY?</p> <p>Yes → Go To 3</p> <p>No → Replace Passenger Airbag in accordance with the Service Information. Perform AIRBAG VERIFICATION TEST - VER 1.</p>	All
3	<p>WARNING: TO AVOID PERSONAL INJURY OR DEATH, TURN THE IGNITION OFF, DISCONNECT THE BATTERY AND WAIT TWO MINUTES BEFORE PROCEEDING. Disconnect the Load Tool from the Passenger Airbag connector(s). Disconnect the Airbag Control Module connector(s).</p> <p>NOTE: Check connectors - Clean and repair as necessary.</p> <p>Connect the appropriate Load Tool Adaptor to the Airbag Control Module connector(s).</p> <p>WARNING: AVOID PERSONAL INJURY OR DEATH, TURN IGNITION ON, THEN RECONNECT THE BATTERY.</p> <p>Measure the voltage on the Passenger Squib 1 Line 1 and Line 2 circuits between the Passenger Airbag connector and ground. Is there any voltage present?</p> <p>Yes → Repair Passenger Squib 1 Line 1 or Line 2 circuit short to battery. Perform AIRBAG VERIFICATION TEST - VER 1.</p> <p>No → Go To 4</p>	All
4	<p>WARNING: IF THE AIRBAG CONTROL MODULE IS DROPPED AT ANY TIME, IT MUST BE REPLACED. FAILURE TO TAKE THE PROPER PRECAUTIONS COULD RESULT IN ACCIDENTAL AIRBAG DEPLOYMENT AND PERSONAL INJURY OR DEATH.</p> <p>If there are no possible causes remaining, view repair.</p> <p>Repair: Replace the Airbag Control Module in accordance with Service Instructions. Perform AIRBAG VERIFICATION TEST - VER 1.</p>	All

PASSENGER SQUIB 1 SHORT TO BATTERY — Continued

TEST	ACTION	APPLICABILITY
5	<p>With the DRBIII®, record and erase all DTC's from all Airbag modules. If equipped with Passenger Airbag On - Off switch, read the DTC's in all switch positions. If any ACTIVE codes are present they must be resolved before diagnosing any stored codes. WARNING: TO AVOID PERSONAL INJURY OR DEATH, TURN THE IGNITION OFF, DISCONNECT THE BATTERY AND WAIT TWO MINUTES BEFORE PROCEEDING. Using the wiring diagram/schematic as a guide, inspect the wiring and connectors. Look for chaffed, pierced, pinched, or partially broken wires and broken, bent, pushed out, spread, corroded, or contaminated terminals. The following additional checks may assist you in identifying a possible intermittent problem. Reconnect any disconnected components and harness connector. WARNING: TO AVOID PERSONAL INJURY OR DEATH, TURN THE IGNITION ON, THEN RECONNECT THE BATTERY. With the DRBIII® monitor active codes as you work through the following steps. WARNING: TO AVOID PERSONAL INJURY OR DEATH, MAINTAIN A SAFE DISTANCE FROM ALL AIRBAGS WHILE PERFORMING THE FOLLOWING STEPS. Wiggle the wiring harness and connectors of the related airbag circuit or component. If codes are related to the Driver circuits, rotate the steering wheel from stop to stop. You have just attempted to simulate the condition that initially set the trouble code message. Did the DTC become active?</p> <p style="padding-left: 40px;">Yes → Select appropriate symptom from Symptom List.</p> <p style="padding-left: 40px;">No → No problem found at this time. Erase all codes before returning vehicle to customer.</p>	All

Symptom:
PASSENGER SQUIB 1 SHORT TO GROUND

When Monitored and Set Condition:

PASSENGER SQUIB 1 SHORT TO GROUND

When Monitored: With the ignition on, the ACM monitors the resistance of the Passenger Squib 1 circuits.

Set Condition: When the ACM detects a short to ground in either Passenger Squib 1 circuits.

POSSIBLE CAUSES
PAB SQUIB 1 CIRCUITS SHORT TO GROUND
PAB SQUIB 1 LINE 1 OR LINE 2 SHORT TO GROUND
ACM, PAB SQUIB 1 SHORT TO GROUND
STORED CODE OR INTERMITTENT CONDITION
ACTIVE CODE PRESENT

TEST	ACTION	APPLICABILITY
1	Turn the ignition on. NOTE: Ensure the battery is fully charged. NOTE: For the purpose of this test, the AECM and ORC modules will be referred to as an ACM. SELECT ACTIVE or STORED DTC: ACM - ACTIVE DTC Go To 2 ACM - STORED DTC Go To 5 NOTE: When reconnecting Airbag system components, the ignition must be turned off and the battery must be disconnected.	All

PASSENGER SQUIB 1 SHORT TO GROUND — Continued

TEST	ACTION	APPLICABILITY
2	<p>WARNING: TO AVOID PERSONAL INJURY OR DEATH, TURN THE IGNITION OFF, DISCONNECT THE BATTERY AND WAIT TWO MINUTES BEFORE PROCEEDING.</p> <p>Disconnect the Passenger Airbag connector(s).</p> <p>NOTE: Check connectors - Clean and repair as necessary.</p> <p>WARNING: DO NOT PLACE AN INTACT UNDEPLOYED AIRBAG FACE DOWN ON A HARD SURFACE, THE AIRBAG WILL PROPEL INTO THE AIR IF ACCIDENTALLY DEPLOYED, AND COULD RESULT IN SERIOUS OR FATAL INJURY.</p> <p>Connect the appropriate Load Tool to the Passenger Airbag connector(s).</p> <p>WARNING: TO AVOID PERSONAL INJURY OR DEATH, TURN THE IGNITION ON, THEN RECONNECT THE BATTERY.</p> <p>With the DRBIII®, read the active Airbag Control Module DTC's.</p> <p>Does the DRBIII® show PASSENGER SQUIB 1 SHORT TO GROUND?</p> <p>Yes → Go To 3</p> <p>No → Replace the Passenger Airbag in accordance with the Service Information. Perform AIRBAG VERIFICATION TEST - VER 1.</p>	All
3	<p>WARNING: TO AVOID PERSONAL INJURY OR DEATH, TURN THE IGNITION OFF, DISCONNECT THE BATTERY AND WAIT TWO MINUTES BEFORE PROCEEDING.</p> <p>Disconnect the Load Tool from the Passenger Airbag connector(s).</p> <p>Disconnect the Airbag Control Module connector(s).</p> <p>NOTE: Check connectors - Clean repair as necessary.</p> <p>Connect the appropriate Load Tool Adaptor to the Airbag Control Module connector.</p> <p>Measure the resistance of the Passenger Squib 1 Line 1 or Line 2 circuit between the Passenger Airbag Module Connector and ground.</p> <p>Is the resistance below 10K ohms on either circuit?</p> <p>Yes → Repair Passenger Squib 1 Line 1 and Line 2 circuits for a short to ground. Perform AIRBAG VERIFICATION TEST - VER 1.</p> <p>No → Go To 4</p>	All
4	<p>WARNING: IF THE AIRBAG CONTROL MODULE IS DROPPED AT ANY TIME, IT MUST BE REPLACED. FAILURE TO TAKE THE PROPER PRECAUTIONS COULD RESULT IN ACCIDENTAL AIRBAG DEPLOYMENT AND PERSONAL INJURY OR DEATH.</p> <p>If there are no possible causes remaining, view repair.</p> <p>Repair:</p> <p>Replace the Airbag Control Module in accordance with Service Information. Perform AIRBAG VERIFICATION TEST - VER 1.</p>	All

PASSENGER SQUIB 1 SHORT TO GROUND — Continued

TEST	ACTION	APPLICABILITY
5	<p>With the DRBIII®, record and erase all DTC's from all Airbag modules.</p> <p>If equipped with Passenger Airbag On - Off switch, read the DTC's in all switch positions.</p> <p>If any ACTIVE codes are present they must be resolved before diagnosing any stored codes.</p> <p>WARNING: TO AVOID PERSONAL INJURY OR DEATH, TURN THE IGNITION OFF, DISCONNECT THE BATTERY AND WAIT TWO MINUTES BEFORE PROCEEDING.</p> <p>Using the wiring diagram/schematic as a guide, inspect the wiring and connectors. Look for chaffed, pierced, pinched, or partially broken wires and broken, bent, pushed out, spread, corroded, or contaminated terminals.</p> <p>The following additional checks may assist you in identifying a possible intermittent problem.</p> <p>Reconnect any disconnected components and harness connector.</p> <p>WARNING: TO AVOID PERSONAL INJURY OR DEATH, TURN THE IGNITION ON, THEN RECONNECT THE BATTERY.</p> <p>With the DRBIII® monitor active codes as you work through the following steps.</p> <p>WARNING: TO AVOID PERSONAL INJURY OR DEATH, MAINTAIN A SAFE DISTANCE FROM ALL AIRBAGS WHILE PERFORMING THE FOLLOWING STEPS.</p> <p>Wiggle the wiring harness and connectors of the related airbag circuit or component. If codes are related to the Driver circuits, rotate the steering wheel from stop to stop. You have just attempted to simulate the condition that initially set the trouble code message.</p> <p>Did the DTC become active?</p> <p style="padding-left: 40px;">Yes → Select appropriate symptom from Symptom List.</p> <p style="padding-left: 40px;">No → No problem found at this time. Erase all codes before returning vehicle to customer.</p>	All

Symptom:

***AIRBAG WARNING INDICATOR FLASHING**

POSSIBLE CAUSES
INITIALIZE AIRBAG CONTROL MODULE ACTIVE CODE PRESENT

TEST	ACTION	APPLICABILITY
1	Erase all DTCs. Cycle the ignition switch OFF then to ON. With the DRBIII®, read the active and stored DTCs. Are all DTC's erased? Yes → With the DRBIII®, perform Airbag Control Module initialization to configure the ACM for this vehicle. Perform AIRBAG VERIFICATION TEST - VER 1. No → Select appropriate symptom from Symptom List.	All

Symptom:

A. HEATER PRE-TEST

POSSIBLE CAUSES

NO RESPONSE FROM CABIN HEATER MODULE OR HEATER BOOSTER MODULE
 CABIN HEATER MODULE OR HEATER BOOSTER MODULE DTC(S) PRESENT
 AUTOMATIC TEMPERATURE CONTROL DTC(S) PRESENT
 HEATER SYSTEM COMPONENTS

TEST	ACTION	APPLICABILITY
1	<p>WARNING: NEVER OPERATE THE HEATER IN AN ENCLOSED AREA THAT DOES NOT HAVE EXHAUST VENTILATION FACILITIES. ALWAYS VENT THE EXHAUST WHEN OPERATING THE HEATER. FAILURE TO FOLLOW THESE INSTRUCTIONS CAN RESULT IN PERSONAL INJURY OR DEATH.</p> <p>Turn the ignition off and either allow the engine coolant to cool down to at least 50°C (122°F) or cold soak the engine.</p> <p>CAUTION: When using a powered exhaust ventilation system, do not attach the exhaust ventilation hose directly to the heater's exhaust pipe. Too much suction can prevent heater operation.</p> <p>When using a powered exhaust ventilation system, affix the ventilation hose to the heater's exhaust pipe or to the vehicle in such a manor that the end of the ventilation hose remains approximately three inches away from the end of the exhaust pipe.</p> <p>When using a non-powered exhaust ventilation system, affix the ventilation hose directly to the heater's exhaust pipe.</p> <p>Turn the ignition on.</p> <p>With the DRBIII®, attempt to communicate with the Cabin Heater Module or Heater Booster Module and the Automatic Temperature Control Module.</p> <p>Does the DRBIII® display: NO RESPONSE?</p> <p>Yes → Refer to the Communication Category for the related symptom. Perform HEATER VERIFICATION TEST - VER 1.</p> <p>No → Go To 2</p>	All

CABIN HEATER

A. HEATER PRE-TEST — Continued

TEST	ACTION	APPLICABILITY
2	<p>WARNING: NEVER OPERATE THE HEATER IN AN ENCLOSED AREA THAT DOES NOT HAVE EXHAUST VENTILATION FACILITIES. ALWAYS VENT THE EXHAUST WHEN OPERATING THE HEATER. FAILURE TO FOLLOW THESE INSTRUCTIONS CAN RESULT IN PERSONAL INJURY OR DEATH.</p> <p>WARNING: ALLOW THE HEATER ASSEMBLY TO COOL BEFORE PERFORMING A COMPONENT INSPECTION/REPAIR/REPLACEMENT. FAILURE TO FOLLOW THESE INSTRUCTIONS CAN RESULT IN PERSONAL INJURY OR DEATH.</p> <p>NOTE: The heater's control unit will store up to five DTCs in its memory.</p> <p>NOTE: If the heater's control unit detects a new fault in the system, one that is not already stored in its memory, it will clear the oldest of the five stored DTCs, and it will store the new fault's DTC.</p> <p>NOTE: If the heater's control unit detects a reoccurrence of a stored fault, it will overwrite that fault's DTC with the most recent occurrence.</p> <p>Turn the ignition on.</p> <p>Verify that the Cabin Heater or Heater Booster is switched off.</p> <p>Set the blend control to the max heat position and the mode control to the floor position.</p> <p>With the DRBIII®, record and erase the Cabin Heater or Heater Booster Module's DTCs.</p> <p>Start the engine. Allow the engine to idle.</p> <p>With the DRBIII®, monitor for Cabin Heater Module or Heater Booster Module DTCs while performing the following step.</p> <p>NOTE: Do not disconnect the vehicle's battery or the heater's main power supply while the heater is in operation or in run-down mode. Failure to follow these instructions can result in excess emissions from the heater during heater operation.</p> <p>Switch the Cabin Heater or Heater Booster on. If operable, allow the heater to run through at least one cycle of operation (approximately 10 minutes), and then switch the heater off.</p> <p>Does the DRBIII® display any DTCs?</p> <p>Yes → If the Heater In Lockout Mode DTC is present, record and erase DTCs before performing any diagnostic procedures. Return to the symptom list and choose the symptom(s). Perform HEATER VERIFICATION TEST - VER 1.</p> <p>No → Go To 3</p>	All

A. HEATER PRE-TEST — Continued

TEST	ACTION	APPLICABILITY
3	<p>WARNING: NEVER OPERATE THE HEATER IN AN ENCLOSED AREA THAT DOES NOT HAVE EXHAUST VENTILATION FACILITIES. ALWAYS VENT THE EXHAUST WHEN OPERATING THE HEATER. FAILURE TO FOLLOW THESE INSTRUCTIONS CAN RESULT IN PERSONAL INJURY OR DEATH.</p> <p>WARNING: ALLOW THE HEATER ASSEMBLY TO COOL BEFORE PERFORMING A COMPONENT INSPECTION/REPAIR/REPLACEMENT. FAILURE TO FOLLOW THESE INSTRUCTIONS CAN RESULT IN PERSONAL INJURY OR DEATH.</p> <p>Turn the ignition on. With the DRBIII®, read Automatic Temperature Control DTCs. Are any DTCs present?</p> <p>Yes → Refer to Heating & A/C information for the related symptom(s). Perform HEATER VERIFICATION TEST - VER 1.</p> <p>No → Allow heater assembly to cool. Inspect the fuel line, air intake and exhaust, and coolant hoses for restrictions, obstructions, loose clamps, leakage, etc. Repair as necessary. Check the harness connectors and grounds. Clean and repair as necessary. Perform HEATER VERIFICATION TEST - VER 1.</p>	All

CABIN HEATER

Symptom: CIRC PUMP CONTROL OPEN

POSSIBLE CAUSES

GROUND CIRCUIT OPEN
CIRCULATION PUMP RELAY HIGH SIDE CONTROL CIRCUIT OPEN
CIRCULATION PUMP RELAY
CABIN HEATER CONTROL UNIT

TEST	ACTION	APPLICABILITY
1	<p>WARNING: NEVER OPERATE THE HEATER IN AN ENCLOSED AREA THAT DOES NOT HAVE EXHAUST VENTILATION FACILITIES. ALWAYS VENT THE EXHAUST WHEN OPERATING THE HEATER. FAILURE TO FOLLOW THESE INSTRUCTIONS CAN RESULT IN PERSONAL INJURY OR DEATH.</p> <p>WARNING: ALLOW THE HEATER ASSEMBLY TO COOL BEFORE PERFORMING A COMPONENT INSPECTION/REPAIR/REPLACEMENT. FAILURE TO FOLLOW THESE INSTRUCTIONS CAN RESULT IN PERSONAL INJURY OR DEATH.</p> <p>CAUTION: DO NOT PERFORM THIS TEST UNLESS DIRECTED HERE BY THE HEATER PRE-TEST. ALWAYS PERFORM THE HEATER PRE-TEST PRIOR TO PERFORMING ANY OTHER TEST FOR THE RESULT TO BE VALID.</p> <p>Turn the ignition off. Remove the Circulation Pump Relay from the relay center. Measure the resistance between ground and the Ground circuit (Circulation Pump Relay connector terminal 85). Is the resistance below 5.0 ohms?</p> <p>Yes → Go To 2</p> <p>No → Repair the Ground circuit for an open. Perform HEATER VERIFICATION TEST - VER 1.</p>	All

CIRC PUMP CONTROL OPEN — Continued

TEST	ACTION	APPLICABILITY
2	<p>WARNING: NEVER OPERATE THE HEATER IN AN ENCLOSED AREA THAT DOES NOT HAVE EXHAUST VENTILATION FACILITIES. ALWAYS VENT THE EXHAUST WHEN OPERATING THE HEATER. FAILURE TO FOLLOW THESE INSTRUCTIONS CAN RESULT IN PERSONAL INJURY OR DEATH.</p> <p>WARNING: ALLOW THE HEATER ASSEMBLY TO COOL BEFORE PERFORMING A COMPONENT INSPECTION/REPAIR/REPLACEMENT. FAILURE TO FOLLOW THESE INSTRUCTIONS CAN RESULT IN PERSONAL INJURY OR DEATH.</p> <p>Turn the ignition off.</p> <p>NOTE: Check connectors - Clean/repair as necessary.</p> <p>Disconnect the Cabin Heater harness connector.</p> <p>Remove the Circulation Pump Relay from the relay center.</p> <p>Measure the resistance of the Circulation Pump Relay High Side Control circuit between the Cabin Heater harness connector and the relay center (Circulation Pump Relay connector terminal 86).</p> <p>Is the resistance below 5.0 ohms?</p> <p>Yes → Go To 3</p> <p>No → Repair the Circulation Pump Relay High Side Control circuit for an open.</p> <p>Perform HEATER VERIFICATION TEST - VER 1.</p>	All
3	<p>WARNING: NEVER OPERATE THE HEATER IN AN ENCLOSED AREA THAT DOES NOT HAVE EXHAUST VENTILATION FACILITIES. ALWAYS VENT THE EXHAUST WHEN OPERATING THE HEATER. FAILURE TO FOLLOW THESE INSTRUCTIONS CAN RESULT IN PERSONAL INJURY OR DEATH.</p> <p>Turn the ignition off.</p> <p>Reconnect the Cabin Heater harness connector.</p> <p>Install a substitute relay in place of the Circulation Pump Relay.</p> <p>Turn the ignition on.</p> <p>Verify that the Cabin Heater is switched off.</p> <p>Set the blend control to the max heat position and the mode control to the floor position.</p> <p>With the DRBIII®, erase the Cabin Heater Module's DTCs.</p> <p>Start the engine. Allow the engine to idle.</p> <p>With the DRBIII, monitor for Cabin Heater Module DTCs while performing the following step.</p> <p>NOTE: Do not disconnect the vehicle's battery or the heater's main power supply while the heater is in operation or in run-down mode. Failure to follow these instructions can result in excess emissions from the heater during heater operation.</p> <p>Switch the Cabin Heater on. If necessary, allow the heater to run through at least one cycle of operation (approximately 10 minutes), and then turn the heater off.</p> <p>Turn the engine off.</p> <p>Does the DRBIII® display: CIRC PUMP CONTROL OPEN?</p> <p>Yes → Replace the Cabin Heater Assembly in accordance with the Service Information. Reinstall the original Circulation Pump Relay.</p> <p>Perform HEATER VERIFICATION TEST - VER 1.</p> <p>No → Replace the original Circulation Pump Relay in accordance with the Service Information.</p> <p>Perform HEATER VERIFICATION TEST - VER 1.</p>	All

CABIN HEATER

Symptom: CIRC PUMP CONTROL SHORTED

POSSIBLE CAUSES

CIRCULATION PUMP RELAY
 CIRCULATION PUMP RELAY HIGH SIDE CONTROL CIRCUIT SHORTED TO GROUND
 PUMP RELAY HIGH SIDE CONTROL CKT SHORTED TO PUMP RELAY GROUND CKT
 CABIN HEATER CONTROL UNIT

TEST	ACTION	APPLICABILITY
1	<p>WARNING: NEVER OPERATE THE HEATER IN AN ENCLOSED AREA THAT DOES NOT HAVE EXHAUST VENTILATION FACILITIES. ALWAYS VENT THE EXHAUST WHEN OPERATING THE HEATER. FAILURE TO FOLLOW THESE INSTRUCTIONS CAN RESULT IN PERSONAL INJURY OR DEATH.</p> <p>CAUTION: DO NOT PERFORM THIS TEST UNLESS DIRECTED HERE BY THE HEATER PRE-TEST. ALWAYS PERFORM THE HEATER PRE-TEST PRIOR TO PERFORMING ANY OTHER TEST FOR THE RESULT TO BE VALID.</p> <p>Turn the ignition off. Install a substitute relay in place of the Circulation Pump Relay. Turn the ignition on. Verify that the Cabin Heater is switched off. Set the blend control to the max heat position and the mode control to the floor position. With the DRBIII®, erase the Cabin Heater Module's DTCs. Start the engine. Allow the engine to idle. With the DRBIII, monitor for Cabin Heater Module DTCs while performing the following step.</p> <p>NOTE: Do not disconnect the vehicle's battery or the heater's main power supply while the heater is in operation or in run-down mode. Failure to follow these instructions can result in excess emissions from the heater during heater operation.</p> <p>Switch the Cabin Heater on. If necessary, allow the heater to run through at least one cycle of operation (approximately 10 minutes), and then switch the heater off. Turn the engine off. Does the DRBIII® display: CIRC PUMP CONTROL SHORTED?</p> <p>Yes → Go To 2</p> <p>No → Replace the original Circulation Pump Relay in accordance with the Service Information. Perform HEATER VERIFICATION TEST - VER 1.</p>	All

CIRC PUMP CONTROL SHORTED — Continued

TEST	ACTION	APPLICABILITY
2	<p>WARNING: NEVER OPERATE THE HEATER IN AN ENCLOSED AREA THAT DOES NOT HAVE EXHAUST VENTILATION FACILITIES. ALWAYS VENT THE EXHAUST WHEN OPERATING THE HEATER. FAILURE TO FOLLOW THESE INSTRUCTIONS CAN RESULT IN PERSONAL INJURY OR DEATH.</p> <p>WARNING: ALLOW THE HEATER ASSEMBLY TO COOL BEFORE PERFORMING A COMPONENT INSPECTION/REPAIR/REPLACEMENT. FAILURE TO FOLLOW THESE INSTRUCTIONS CAN RESULT IN PERSONAL INJURY OR DEATH.</p> <p>Turn the ignition off.</p> <p>NOTE: Check connectors - Clean/repair as necessary.</p> <p>Disconnect the Cabin Heater harness connector.</p> <p>Remove the substitute Circulation Pump Relay from the relay center.</p> <p>Measure the resistance between ground and the Circulation Pump Relay High Side Control circuit.</p> <p>Is the resistance below 10K ohms?</p> <p>Yes → Repair the Circulation Pump Relay High Side Control circuit for a short to ground. Reinstall the original Circulation Pump Relay. Perform HEATER VERIFICATION TEST - VER 1.</p> <p>No → Go To 3</p>	All
3	<p>WARNING: NEVER OPERATE THE HEATER IN AN ENCLOSED AREA THAT DOES NOT HAVE EXHAUST VENTILATION FACILITIES. ALWAYS VENT THE EXHAUST WHEN OPERATING THE HEATER. FAILURE TO FOLLOW THESE INSTRUCTIONS CAN RESULT IN PERSONAL INJURY OR DEATH.</p> <p>WARNING: ALLOW THE HEATER ASSEMBLY TO COOL BEFORE PERFORMING A COMPONENT INSPECTION/REPAIR/REPLACEMENT. FAILURE TO FOLLOW THESE INSTRUCTIONS CAN RESULT IN PERSONAL INJURY OR DEATH.</p> <p>Turn the ignition off.</p> <p>NOTE: Check connectors - Clean/repair as necessary.</p> <p>Disconnect the Cabin Heater harness connector.</p> <p>Remove the Circulation Pump Relay from the relay center.</p> <p>Measure the resistance between the Circulation Pump Relay High Side Control circuit and the Ground circuit (Circulation Pump Relay connector terminal 86 and 85).</p> <p>Is the resistance below 10K ohms?</p> <p>Yes → Repair the Circulation Pump Relay High Side Control circuit for a short to the Ground circuit. Perform HEATER VERIFICATION TEST - VER 1.</p> <p>No → Replace the Cabin Heater Assembly in accordance with the Service Information. Perform HEATER VERIFICATION TEST - VER 1.</p>	All

CABIN HEATER

Symptom List:

COMBUST FAN SHORTED
COMBUST FAN SPEED INCORRECT
COMBUSTION FAN OPEN

**Test Note: All symptoms listed above are diagnosed using the same tests.
The title for the tests will be COMBUST FAN SHORTED.**

POSSIBLE CAUSES

COMBUSTION AIR FAN

TEST	ACTION	APPLICABILITY
1	<p>WARNING: NEVER OPERATE THE HEATER IN AN ENCLOSED AREA THAT DOES NOT HAVE EXHAUST VENTILATION FACILITIES. ALWAYS VENT THE EXHAUST WHEN OPERATING THE HEATER. FAILURE TO FOLLOW THESE INSTRUCTIONS CAN RESULT IN PERSONAL INJURY OR DEATH.</p> <p>WARNING: ALLOW THE HEATER ASSEMBLY TO COOL BEFORE PERFORMING A COMPONENT INSPECTION/REPAIR/REPLACEMENT. FAILURE TO FOLLOW THESE INSTRUCTIONS CAN RESULT IN PERSONAL INJURY OR DEATH.</p> <p>CAUTION: DO NOT PERFORM THIS TEST UNLESS DIRECTED HERE BY THE HEATER PRE-TEST. ALWAYS PERFORM THE HEATER PRE-TEST PRIOR TO PERFORMING ANY OTHER TEST FOR THE RESULT TO BE VALID.</p> <p>Turn the ignition off. View repair</p> <p>Repair</p> <p>Replace the Cabin Heater Assembly or Heater Booster Assembly in accordance with the Service Information. Perform HEATER VERIFICATION TEST - VER 1.</p>	All

Symptom:
CONTROL UNIT FAULTY

When Monitored and Set Condition:

CONTROL UNIT FAULTY

When Monitored: During heater activation and operation.

Set Condition: This DTC will set if the heater's control unit detects an internal failure in its microprocessor/memory.

POSSIBLE CAUSES

CABIN HEATER OR HEATER BOOSTER CONTROL UNIT

TEST	ACTION	APPLICABILITY
1	<p>WARNING: NEVER OPERATE THE HEATER IN AN ENCLOSED AREA THAT DOES NOT HAVE EXHAUST VENTILATION FACILITIES. ALWAYS VENT THE EXHAUST WHEN OPERATING THE HEATER. FAILURE TO FOLLOW THESE INSTRUCTIONS CAN RESULT IN PERSONAL INJURY OR DEATH.</p> <p>WARNING: ALLOW THE HEATER ASSEMBLY TO COOL BEFORE PERFORMING A COMPONENT INSPECTION/REPAIR/REPLACEMENT. FAILURE TO FOLLOW THESE INSTRUCTIONS CAN RESULT IN PERSONAL INJURY OR DEATH.</p> <p>CAUTION: DO NOT PERFORM THIS TEST UNLESS DIRECTED HERE BY THE HEATER PRE-TEST. ALWAYS PERFORM THE HEATER PRE-TEST PRIOR TO PERFORMING ANY OTHER TEST FOR THE RESULT TO BE VALID.</p> <p>Turn the ignition off. View repair</p> <p>Repair</p> <p>Replace the Cabin Heater Assembly or Heater Booster Assembly in accordance with the Service Information. Perform HEATER VERIFICATION TEST - VER 1.</p>	All

CABIN HEATER

Symptom: DOSING PUMP OPEN

When Monitored and Set Condition:

DOSING PUMP OPEN

When Monitored: With the ignition on.

Set Condition: This DTC will set if the heater's control unit detects abnormally high voltage on the Dosing Pump control circuit.

POSSIBLE CAUSES

DOSING PUMP CONTROL CIRCUIT SHORTED HIGH
 DOSING PUMP
 DOSING PUMP CONTROL CIRCUIT OPEN
 GROUND CIRCUIT OPEN
 CABIN HEATER OR HEATER BOOSTER CONTROL UNIT

TEST	ACTION	APPLICABILITY
1	<p>WARNING: NEVER OPERATE THE HEATER IN AN ENCLOSED AREA THAT DOES NOT HAVE EXHAUST VENTILATION FACILITIES. ALWAYS VENT THE EXHAUST WHEN OPERATING THE HEATER. FAILURE TO FOLLOW THESE INSTRUCTIONS CAN RESULT IN PERSONAL INJURY OR DEATH.</p> <p>WARNING: ALLOW THE HEATER ASSEMBLY TO COOL BEFORE PERFORMING A COMPONENT INSPECTION/REPAIR/REPLACEMENT. FAILURE TO FOLLOW THESE INSTRUCTIONS CAN RESULT IN PERSONAL INJURY OR DEATH.</p> <p>CAUTION: DO NOT PERFORM THIS TEST UNLESS DIRECTED HERE BY THE HEATER PRE-TEST. ALWAYS PERFORM THE HEATER PRE-TEST PRIOR TO PERFORMING ANY OTHER TEST FOR THE RESULT TO BE VALID.</p> <p>Turn the ignition off.</p> <p>NOTE: Check connectors - Clean/repair as necessary.</p> <p>Disconnect the Cabin Heater or Heater Booster harness connector.</p> <p>Turn the ignition on.</p> <p>Measure the voltage between the Dosing Pump Control circuit and ground. Is the voltage above 0.2 volts?</p> <p>Yes → Repair the Dosing Pump Control circuit for a short to voltage. Perform HEATER VERIFICATION TEST - VER 1.</p> <p>No → Go To 2</p>	All

DOSING PUMP OPEN — Continued

TEST	ACTION	APPLICABILITY
2	<p>WARNING: NEVER OPERATE THE HEATER IN AN ENCLOSED AREA THAT DOES NOT HAVE EXHAUST VENTILATION FACILITIES. ALWAYS VENT THE EXHAUST WHEN OPERATING THE HEATER. FAILURE TO FOLLOW THESE INSTRUCTIONS CAN RESULT IN PERSONAL INJURY OR DEATH.</p> <p>WARNING: ALLOW THE HEATER ASSEMBLY TO COOL BEFORE PERFORMING A COMPONENT INSPECTION/REPAIR/REPLACEMENT. FAILURE TO FOLLOW THESE INSTRUCTIONS CAN RESULT IN PERSONAL INJURY OR DEATH.</p> <p>Turn the ignition off.</p> <p>NOTE: Check connectors - Clean/repair as necessary.</p> <p>Reconnect the Cabin Heater or Heater Booster harness connector.</p> <p>Disconnect the Dosing Pump harness connector.</p> <p>Connect a 12-volt test light between the Dosing Pump Control circuit and the Ground circuit in the Dosing Pump harness connector.</p> <p>Turn the ignition on.</p> <p>With the DRBIII® in System Tests, select Dosing Pump Output. The test Light should illuminate brightly and flash continuously during actuation.</p> <p>Does the test light operate as specified?</p> <p style="padding-left: 40px;">Yes → Replace the Dosing Pump in accordance with the Service Information. Perform HEATER VERIFICATION TEST - VER 1.</p> <p style="padding-left: 40px;">No → Go To 3</p>	All
3	<p>WARNING: NEVER OPERATE THE HEATER IN AN ENCLOSED AREA THAT DOES NOT HAVE EXHAUST VENTILATION FACILITIES. ALWAYS VENT THE EXHAUST WHEN OPERATING THE HEATER. FAILURE TO FOLLOW THESE INSTRUCTIONS CAN RESULT IN PERSONAL INJURY OR DEATH.</p> <p>WARNING: ALLOW THE HEATER ASSEMBLY TO COOL BEFORE PERFORMING A COMPONENT INSPECTION/REPAIR/REPLACEMENT. FAILURE TO FOLLOW THESE INSTRUCTIONS CAN RESULT IN PERSONAL INJURY OR DEATH.</p> <p>Turn the ignition off.</p> <p>NOTE: Check connectors - Clean/repair as necessary.</p> <p>Disconnect the Cabin Heater or Heater Booster harness connector.</p> <p>NOTE: Check connectors - Clean/repair as necessary.</p> <p>Disconnect the Dosing Pump harness connector.</p> <p>Measure the resistance of the Dosing Pump Control circuit between the Dosing Pump harness connector and the Cabin Heater or Heater Booster harness connector (as applicable).</p> <p>Is the resistance below 5.0 ohms?</p> <p style="padding-left: 40px;">Yes → Go To 4</p> <p style="padding-left: 40px;">No → Repair the Dosing Pump Control circuit for an open. Perform HEATER VERIFICATION TEST - VER 1.</p>	All

CABIN HEATER

DOSING PUMP OPEN — Continued

TEST	ACTION	APPLICABILITY
4	<p>WARNING: NEVER OPERATE THE HEATER IN AN ENCLOSED AREA THAT DOES NOT HAVE EXHAUST VENTILATION FACILITIES. ALWAYS VENT THE EXHAUST WHEN OPERATING THE HEATER. FAILURE TO FOLLOW THESE INSTRUCTIONS CAN RESULT IN PERSONAL INJURY OR DEATH.</p> <p>WARNING: ALLOW THE HEATER ASSEMBLY TO COOL BEFORE PERFORMING A COMPONENT INSPECTION/REPAIR/REPLACEMENT. FAILURE TO FOLLOW THESE INSTRUCTIONS CAN RESULT IN PERSONAL INJURY OR DEATH.</p> <p>Turn the ignition off.</p> <p>NOTE: Check connectors - Clean/repair as necessary. Disconnect the Cabin Heater or Heater Booster harness connector.</p> <p>NOTE: Check connectors - Clean/repair as necessary. Disconnect the Dosing Pump harness connector.</p> <p>Measure the resistance of the Ground circuit between the Dosing Pump harness connector and the Cabin Heater or Heater Booster harness connector. Is the resistance below 5.0 ohms?</p> <p>Yes → Replace the Cabin Heater Assembly or Heater Booster Assembly in accordance with the Service Information. Perform HEATER VERIFICATION TEST - VER 1.</p> <p>No → Repair the Ground circuit for an open. Perform HEATER VERIFICATION TEST - VER 1.</p>	All

Symptom:
DOSING PUMP SHORTED

POSSIBLE CAUSES

DOSING PUMP SHORTED TO GROUND
 DOSING PUMP CONTROL CIRCUIT SHORTED TO GROUND CIRCUIT
 DOSING PUMP CONTROL CIRCUIT SHORTED TO GROUND
 CABIN HEATER OR HEATER BOOSTER CONTROL UNIT

TEST	ACTION	APPLICABILITY
1	<p>WARNING: NEVER OPERATE THE HEATER IN AN ENCLOSED AREA THAT DOES NOT HAVE EXHAUST VENTILATION FACILITIES. ALWAYS VENT THE EXHAUST WHEN OPERATING THE HEATER. FAILURE TO FOLLOW THESE INSTRUCTIONS CAN RESULT IN PERSONAL INJURY OR DEATH.</p> <p>WARNING: ALLOW THE HEATER ASSEMBLY TO COOL BEFORE PERFORMING A COMPONENT INSPECTION/REPAIR/REPLACEMENT. FAILURE TO FOLLOW THESE INSTRUCTIONS CAN RESULT IN PERSONAL INJURY OR DEATH.</p> <p>CAUTION: DO NOT PERFORM THIS TEST UNLESS DIRECTED HERE BY THE HEATER PRE-TEST. ALWAYS PERFORM THE HEATER PRE-TEST PRIOR TO PERFORMING ANY OTHER TEST FOR THE RESULT TO BE VALID.</p> <p>Turn the ignition off.</p> <p>NOTE: Check connectors - Clean/repair as necessary.</p> <p>Disconnect the Dosing Pump harness connector.</p> <p>Turn the ignition on.</p> <p>Verify that the Cabin Heater or Heater Booster is switched off.</p> <p>Set the blend control to the max heat position and the mode control to the floor position.</p> <p>With the DRBIII®, erase the Cabin Heater or Heater Booster Module's DTCs.</p> <p>Start the engine. Allow the engine to idle.</p> <p>With the DRBIII, monitor for Cabin Heater or Heater Booster Module DTCs while performing the following step.</p> <p>NOTE: Do not disconnect the vehicle's battery or the heater's main power supply while the heater is in operation or in run-down mode. Failure to follow these instructions can result in excess emissions from the heater during heater operation.</p> <p>Switch the Cabin Heater or Heater Booster on. If necessary, allow the heater to run through at least one cycle of operation (approximately 10 minutes), and then switch the heater off.</p> <p>Turn the engine off.</p> <p>Does the DRBIII® display: DOSING PUMP HIGH OR OPEN?</p> <p style="padding-left: 40px;">Yes → Replace the Dosing Pump in accordance with the Service Information. Perform HEATER VERIFICATION TEST - VER 1.</p> <p style="padding-left: 40px;">No → Go To 2</p>	All

CABIN HEATER

DOSING PUMP SHORTED — Continued

TEST	ACTION	APPLICABILITY
2	<p>WARNING: NEVER OPERATE THE HEATER IN AN ENCLOSED AREA THAT DOES NOT HAVE EXHAUST VENTILATION FACILITIES. ALWAYS VENT THE EXHAUST WHEN OPERATING THE HEATER. FAILURE TO FOLLOW THESE INSTRUCTIONS CAN RESULT IN PERSONAL INJURY OR DEATH.</p> <p>WARNING: ALLOW THE HEATER ASSEMBLY TO COOL BEFORE PERFORMING A COMPONENT INSPECTION/REPAIR/REPLACEMENT. FAILURE TO FOLLOW THESE INSTRUCTIONS CAN RESULT IN PERSONAL INJURY OR DEATH.</p> <p>Turn the ignition off.</p> <p>Disconnect the battery in accordance with the Service information.</p> <p>NOTE: Check connectors - Clean/repair as necessary.</p> <p>Disconnect the Cabin Heater or Heater Booster harness connector.</p> <p>NOTE: Check connectors - Clean/repair as necessary.</p> <p>Disconnect the Dosing Pump harness connector.</p> <p>Measure the resistance between the Dosing Pump Control circuit and the Ground circuit in the Dosing Pump harness connector.</p> <p>Is the resistance below 10K ohms?</p> <p style="padding-left: 40px;">Yes → Repair the Dosing Pump Control circuit for a short to the Ground circuit. Perform HEATER VERIFICATION TEST - VER 1.</p> <p style="padding-left: 40px;">No → Go To 3</p>	All
3	<p>WARNING: NEVER OPERATE THE HEATER IN AN ENCLOSED AREA THAT DOES NOT HAVE EXHAUST VENTILATION FACILITIES. ALWAYS VENT THE EXHAUST WHEN OPERATING THE HEATER. FAILURE TO FOLLOW THESE INSTRUCTIONS CAN RESULT IN PERSONAL INJURY OR DEATH.</p> <p>WARNING: ALLOW THE HEATER ASSEMBLY TO COOL BEFORE PERFORMING A COMPONENT INSPECTION/REPAIR/REPLACEMENT. FAILURE TO FOLLOW THESE INSTRUCTIONS CAN RESULT IN PERSONAL INJURY OR DEATH.</p> <p>Turn the ignition off.</p> <p>Disconnect the battery in accordance with the Service information.</p> <p>NOTE: Check connectors - Clean/repair as necessary.</p> <p>Disconnect the Cabin Heater or Heater Booster harness connector.</p> <p>NOTE: Check connectors - Clean/repair as necessary.</p> <p>Disconnect the Dosing Pump harness connector.</p> <p>Measure the resistance between ground and the Dosing Pump Control circuit.</p> <p>Is the resistance below 10K ohms?</p> <p style="padding-left: 40px;">Yes → Repair the Dosing Pump Control circuit for a short to ground. Perform HEATER VERIFICATION TEST - VER 1.</p> <p style="padding-left: 40px;">No → Replace the Cabin Heater Assembly or Heater Booster Assembly in accordance with the Service Information. Perform HEATER VERIFICATION TEST - VER 1.</p>	All

Symptom:
FAN STAGE 1 RELAY CONTROL OPEN

POSSIBLE CAUSES
<p>GROUND CIRCUIT OPEN</p> <p>FAN STAGE 1 RELAY HIGH SIDE CONTROL CIRCUIT OPEN</p> <p>FAN STAGE 1 RELAY</p> <p>CABIN HEATER CONTROL UNIT</p>

TEST	ACTION	APPLICABILITY
1	<p>WARNING: NEVER OPERATE THE HEATER IN AN ENCLOSED AREA THAT DOES NOT HAVE EXHAUST VENTILATION FACILITIES. ALWAYS VENT THE EXHAUST WHEN OPERATING THE HEATER. FAILURE TO FOLLOW THESE INSTRUCTIONS CAN RESULT IN PERSONAL INJURY OR DEATH.</p> <p>WARNING: ALLOW THE HEATER ASSEMBLY TO COOL BEFORE PERFORMING A COMPONENT INSPECTION/REPAIR/REPLACEMENT. FAILURE TO FOLLOW THESE INSTRUCTIONS CAN RESULT IN PERSONAL INJURY OR DEATH.</p> <p>CAUTION: DO NOT PERFORM THIS TEST UNLESS DIRECTED HERE BY THE HEATER PRE-TEST. ALWAYS PERFORM THE HEATER PRE-TEST PRIOR TO PERFORMING ANY OTHER TEST FOR THE RESULT TO BE VALID.</p> <p>Turn the ignition off.</p> <p>Remove the Fan Stage 1 Relay from the relay center.</p> <p>Measure the resistance between ground and the Ground circuit in the relay center (Fan Stage 1 Relay connector terminal 85).</p> <p>Is the resistance below 5.0 ohms?</p> <p style="padding-left: 40px;">Yes → Go To 2</p> <p style="padding-left: 40px;">No → Repair the Ground circuit for an open. Perform HEATER VERIFICATION TEST - VER 1.</p>	All

FAN STAGE 1 RELAY CONTROL OPEN — Continued

TEST	ACTION	APPLICABILITY
2	<p>WARNING: NEVER OPERATE THE HEATER IN AN ENCLOSED AREA THAT DOES NOT HAVE EXHAUST VENTILATION FACILITIES. ALWAYS VENT THE EXHAUST WHEN OPERATING THE HEATER. FAILURE TO FOLLOW THESE INSTRUCTIONS CAN RESULT IN PERSONAL INJURY OR DEATH.</p> <p>WARNING: ALLOW THE HEATER ASSEMBLY TO COOL BEFORE PERFORMING A COMPONENT INSPECTION/REPAIR/REPLACEMENT. FAILURE TO FOLLOW THESE INSTRUCTIONS CAN RESULT IN PERSONAL INJURY OR DEATH.</p> <p>Turn the ignition off.</p> <p>NOTE: Check connectors - Clean/repair as necessary.</p> <p>Disconnect the Cabin Heater harness connector.</p> <p>Remove the Fan Stage 1 Relay from the relay center.</p> <p>Measure the resistance of the Fan Stage 1 Relay High Side Control circuit between the Cabin Heater harness connector and the relay center (Fan Stage 1 Relay connector terminal 86).</p> <p>Is the resistance below 5.0 ohms?</p> <p style="padding-left: 40px;">Yes → Go To 3</p> <p style="padding-left: 40px;">No → Repair the Fan Stage 1 Relay High Side Control circuit for an open.</p> <p style="padding-left: 40px;">Perform HEATER VERIFICATION TEST - VER 1.</p>	All
3	<p>WARNING: NEVER OPERATE THE HEATER IN AN ENCLOSED AREA THAT DOES NOT HAVE EXHAUST VENTILATION FACILITIES. ALWAYS VENT THE EXHAUST WHEN OPERATING THE HEATER. FAILURE TO FOLLOW THESE INSTRUCTIONS CAN RESULT IN PERSONAL INJURY OR DEATH.</p> <p>Turn the ignition off.</p> <p>Reconnect the Cabin Heater harness connector.</p> <p>Install a substitute relay in place of the Fan Stage 1 Relay.</p> <p>Turn the ignition on.</p> <p>Verify that the Cabin Heater is switched off.</p> <p>Set the blend control to the max heat position and the mode control to the floor position.</p> <p>With the DRBIII®, erase the Cabin Heater Module's DTCs.</p> <p>Start the engine. Allow the engine to idle.</p> <p>With the DRBIII, monitor for Cabin Heater Module DTCs while performing the following step.</p> <p>NOTE: Do not disconnect the vehicle's battery or the heater's main power supply while the heater is in operation or in run-down mode. Failure to follow these instructions can result in excess emissions from the heater during heater operation.</p> <p>Switch the Cabin Heater on. If necessary, allow the heater to run through at least one cycle of operation (approximately 10 minutes), and then switch the heater off.</p> <p>Turn the engine off.</p> <p>Does the DRBIII® display: FAN STAGE 1 RELAY CONTROL OPEN?</p> <p style="padding-left: 40px;">Yes → Replace the Cabin Heater Assembly in accordance with the Service Information. Reinstall the original Fan Stage 1 Relay.</p> <p style="padding-left: 40px;">Perform HEATER VERIFICATION TEST - VER 1.</p> <p style="padding-left: 40px;">No → Replace the original Fan Stage 1 Relay in accordance with the Service Information.</p> <p style="padding-left: 40px;">Perform HEATER VERIFICATION TEST - VER 1.</p>	All

Symptom:
FAN STAGE 1 RELAY CONTROL SHORTED

POSSIBLE CAUSES
<p>FAN STAGE 1 RELAY FAN STAGE 1 RELAY HIGH SIDE CONTROL CIRCUIT SHORTED TO GROUND FAN STAGE 1 RELAY HIGH SIDE CONTROL CIRCUIT SHORTED TO GROUND CIRCUIT CABIN HEATER CONTROL UNIT</p>

TEST	ACTION	APPLICABILITY
1	<p>WARNING: NEVER OPERATE THE HEATER IN AN ENCLOSED AREA THAT DOES NOT HAVE EXHAUST VENTILATION FACILITIES. ALWAYS VENT THE EXHAUST WHEN OPERATING THE HEATER. FAILURE TO FOLLOW THESE INSTRUCTIONS CAN RESULT IN PERSONAL INJURY OR DEATH.</p> <p>CAUTION: DO NOT PERFORM THIS TEST UNLESS DIRECTED HERE BY THE HEATER PRE-TEST. ALWAYS PERFORM THE HEATER PRE-TEST PRIOR TO PERFORMING ANY OTHER TEST FOR THE RESULT TO BE VALID.</p> <p>Turn the ignition off. Install a substitute relay in place of the Fan Stage 1 Relay. Turn the ignition on. Verify that the Cabin Heater is switched off. Set the blend control to the max heat position and the mode control to the floor position. With the DRBIII®, erase the Cabin Heater Module's DTCs. Start the engine. Allow the engine to idle. With the DRBIII, monitor for Cabin Heater Module DTCs while performing the following step.</p> <p>NOTE: Do not disconnect the vehicle's battery or the heater's main power supply while the heater is in operation or in run-down mode. Failure to follow these instructions can result in excess emissions from the heater during heater operation.</p> <p>Switch the Cabin Heater on. If necessary, allow the heater to run through at least one cycle of operation (approximately 10 minutes), and then switch the heater off. Turn the engine off. Does the DRBIII® display: FAN STAGE 1 RELAY CONTROL SHORTED?</p> <p style="padding-left: 40px;">Yes → Go To 2</p> <p style="padding-left: 40px;">No → Replace the original Fan Stage 1 Relay in accordance with the Service Information. Perform HEATER VERIFICATION TEST - VER 1.</p>	All

FAN STAGE 1 RELAY CONTROL SHORTED — Continued

TEST	ACTION	APPLICABILITY
2	<p>WARNING: NEVER OPERATE THE HEATER IN AN ENCLOSED AREA THAT DOES NOT HAVE EXHAUST VENTILATION FACILITIES. ALWAYS VENT THE EXHAUST WHEN OPERATING THE HEATER. FAILURE TO FOLLOW THESE INSTRUCTIONS CAN RESULT IN PERSONAL INJURY OR DEATH.</p> <p>WARNING: ALLOW THE HEATER ASSEMBLY TO COOL BEFORE PERFORMING A COMPONENT INSPECTION/REPAIR/REPLACEMENT. FAILURE TO FOLLOW THESE INSTRUCTIONS CAN RESULT IN PERSONAL INJURY OR DEATH.</p> <p>Turn the ignition off.</p> <p>NOTE: Check connectors - Clean/repair as necessary.</p> <p>Disconnect the Cabin Heater harness connector.</p> <p>Remove the substitute Fan Stage 1 Relay from the relay center.</p> <p>Measure the resistance between ground and the Fan Stage 1 Relay High Side Control circuit.</p> <p>Is the resistance below 10K ohms?</p> <p style="padding-left: 40px;">Yes → Repair the Fan Stage 1 Relay High Side Control circuit for a short to ground. Reinstall the original Fan Stage 1 Relay. Perform HEATER VERIFICATION TEST - VER 1.</p> <p style="padding-left: 40px;">No → Go To 3</p>	All
3	<p>WARNING: NEVER OPERATE THE HEATER IN AN ENCLOSED AREA THAT DOES NOT HAVE EXHAUST VENTILATION FACILITIES. ALWAYS VENT THE EXHAUST WHEN OPERATING THE HEATER. FAILURE TO FOLLOW THESE INSTRUCTIONS CAN RESULT IN PERSONAL INJURY OR DEATH.</p> <p>WARNING: ALLOW THE HEATER ASSEMBLY TO COOL BEFORE PERFORMING A COMPONENT INSPECTION/REPAIR/REPLACEMENT. FAILURE TO FOLLOW THESE INSTRUCTIONS CAN RESULT IN PERSONAL INJURY OR DEATH.</p> <p>Turn the ignition off.</p> <p>NOTE: Check connectors - Clean/repair as necessary.</p> <p>Disconnect the Cabin Heater harness connector.</p> <p>Remove the Fan Stage 1 Relay from the relay center.</p> <p>Measure the resistance between the Fan Stage 1 Relay High Side Control circuit and the Ground circuit (Fan Stage 1 Relay connector terminal 86 and 85).</p> <p>Is the resistance below 10K ohms?</p> <p style="padding-left: 40px;">Yes → Repair the Fan Stage 1 Relay High Side Control circuit for a short to the Ground circuit. Perform HEATER VERIFICATION TEST - VER 1.</p> <p style="padding-left: 40px;">No → Replace the Cabin Heater Assembly in accordance with the Service Information. Perform HEATER VERIFICATION TEST - VER 1.</p>	All

Symptom:
FLAME DETECT PRIOR TO COMBUST

When Monitored and Set Condition:

FLAME DETECT PRIOR TO COMBUST

When Monitored: During heater start up.

Set Condition: This DTC will set if the Flame Sensor's resistance is not within the expected parameters.

POSSIBLE CAUSES

HEATER'S AIR INTAKE/EXHAUST RESTRICTED
 FLAME SENSOR

TEST	ACTION	APPLICABILITY
1	<p>WARNING: NEVER OPERATE THE HEATER IN AN ENCLOSED AREA THAT DOES NOT HAVE EXHAUST VENTILATION FACILITIES. ALWAYS VENT THE EXHAUST WHEN OPERATING THE HEATER. FAILURE TO FOLLOW THESE INSTRUCTIONS CAN RESULT IN PERSONAL INJURY OR DEATH.</p> <p>WARNING: ALLOW THE HEATER ASSEMBLY TO COOL BEFORE PERFORMING A COMPONENT INSPECTION/REPAIR/REPLACEMENT. FAILURE TO FOLLOW THESE INSTRUCTIONS CAN RESULT IN PERSONAL INJURY OR DEATH.</p> <p>CAUTION: DO NOT PERFORM THIS TEST UNLESS DIRECTED HERE BY THE HEATER PRE-TEST. ALWAYS PERFORM THE HEATER PRE-TEST PRIOR TO PERFORMING ANY OTHER TEST FOR THE RESULT TO BE VALID.</p> <p>Turn the ignition off. Inspect the heater's air intake pipe and exhaust pipe for restrictions and obstructions. Is the heater's air intake pipe and exhaust pipe Ok?</p> <p>Yes → Replace the Cabin Heater Assembly or Heater Booster Assembly in accordance with the Service Information. Perform HEATER VERIFICATION TEST - VER 1.</p> <p>No → Repair the heater's air intake/exhaust as necessary in accordance with the Service Information. Perform HEATER VERIFICATION TEST - VER 1.</p>	All

Symptom List:

**FLAME OUT
NO START**

**Test Note: All symptoms listed above are diagnosed using the same tests.
The title for the tests will be FLAME OUT.**

When Monitored and Set Condition:**FLAME OUT**

When Monitored: After heater activation and during subsequent attempts to start the heater.

Set Condition: This DTC will set if the Flame Sensor's resistance is not within the expected parameters.

NO START

When Monitored: After heater activation.

Set Condition: This DTC will set if the Flame Sensor's resistance is not within the expected parameters 340 seconds after activation.

POSSIBLE CAUSES
LOW FUEL LEVEL IN VEHICLE'S FUEL TANK
HEATER'S FUEL LINE RESTRICTED/LEAKING/DAMAGED
DOSING PUMP
HEATER'S AIR INTAKE/EXHAUST RESTRICTED
CABIN HEATER ASSEMBLY OR HEATER BOOSTER ASSEMBLY

FLAME OUT — Continued

TEST	ACTION	APPLICABILITY
1	<p>WARNING: NEVER OPERATE THE HEATER IN AN ENCLOSED AREA THAT DOES NOT HAVE EXHAUST VENTILATION FACILITIES. ALWAYS VENT THE EXHAUST WHEN OPERATING THE HEATER. FAILURE TO FOLLOW THESE INSTRUCTIONS CAN RESULT IN PERSONAL INJURY OR DEATH.</p> <p>WARNING: ALWAYS SWITCH THE HEATER OFF PRIOR TO REFUELING THE VEHICLE. FAILURE TO FOLLOW THESE INSTRUCTIONS CAN RESULT IN PERSONAL INJURY OR DEATH.</p> <p>CAUTION: DO NOT PERFORM THIS TEST UNLESS DIRECTED HERE BY THE HEATER PRE-TEST. ALWAYS PERFORM THE HEATER PRE-TEST PRIOR TO PERFORMING ANY OTHER TEST FOR THE RESULT TO BE VALID.</p> <p>Verify that there is more than an 1/8 of a tank of fuel in the vehicle's fuel tank. Is there more than an 1/8 of a tank of fuel in the vehicle's fuel tank?</p> <p>Yes → Go To 2</p> <p>No → Add fuel to the vehicle's fuel tank to bring the fuel level above 1/8 of a tank. Perform HEATER VERIFICATION TEST - VER 1.</p>	All
2	<p>WARNING: NEVER OPERATE THE HEATER IN AN ENCLOSED AREA THAT DOES NOT HAVE EXHAUST VENTILATION FACILITIES. ALWAYS VENT THE EXHAUST WHEN OPERATING THE HEATER. FAILURE TO FOLLOW THESE INSTRUCTIONS CAN RESULT IN PERSONAL INJURY OR DEATH.</p> <p>WARNING: ALLOW THE HEATER ASSEMBLY TO COOL BEFORE PERFORMING A COMPONENT INSPECTION/REPAIR/REPLACEMENT. FAILURE TO FOLLOW THESE INSTRUCTIONS CAN RESULT IN PERSONAL INJURY OR DEATH.</p> <p>Turn the ignition off. Inspect the heater's fuel line exterior for restrictions, leakage, and damage. Verify that the heater's fuel line is installed correctly.</p> <p>NOTE: Waxed fuel can obstruct the fuel line and reduce flow. Check for the appropriate winter grade fuel and replace as necessary.</p> <p>Check for obstructions in the heater's fuel line. Refer to Fuel Line, Cleaning in the Service Information. Is the heater's fuel line Ok?</p> <p>Yes → Go To 3</p> <p>No → Repair the heater's fuel line as necessary in accordance with the Service Information. Perform HEATER VERIFICATION TEST - VER 1.</p>	All

CABIN HEATER

FLAME OUT — Continued

TEST	ACTION	APPLICABILITY
3	<p>WARNING: NEVER OPERATE THE HEATER IN AN ENCLOSED AREA THAT DOES NOT HAVE EXHAUST VENTILATION FACILITIES. ALWAYS VENT THE EXHAUST WHEN OPERATING THE HEATER. FAILURE TO FOLLOW THESE INSTRUCTIONS CAN RESULT IN PERSONAL INJURY OR DEATH.</p> <p>WARNING: ALLOW THE HEATER ASSEMBLY TO COOL BEFORE PERFORMING A COMPONENT INSPECTION/REPAIR/REPLACEMENT. FAILURE TO FOLLOW THESE INSTRUCTIONS CAN RESULT IN PERSONAL INJURY OR DEATH.</p> <p>Turn the ignition off.</p> <p>Disconnect the fuel line from the fuel outlet side of the Dosing Pump.</p> <p>Using a suitable length of fuel line, connect one end to the fuel outlet side of the Dosing Pump and place the other end in a suitable container.</p> <p>Turn the ignition on.</p> <p>CAUTION: For the result of this test to be valid, the vehicle's battery must be fully charged.</p> <p>CAUTION: For the result of the Dosing Pump OUTPUT test to be valid, actuate Dosing Pump PRIME if the heater's fuel supply line was drained & then not primed. Remove any fuel in the container before performing the Dosing Pump OUTPUT test.</p> <p>If the heater's fuel supply line was drained and then not primed, with the DRBIII® in System Tests, actuate Dosing Pump PRIME. Otherwise, proceed to the next step of this procedure.</p> <p>With the DRBIII® in System Tests, select Dosing Pump OUTPUT. Allow the Dosing Pump Output test to run the full 90 seconds. When the Dosing Pump Output test is complete, measure the amount of fuel in the container.</p> <p>Does the dosing pump output 422 - 636 cc (14.26 - 21.5 oz) in 90 seconds?</p> <p>Yes → Go To 4</p> <p>No → Replace the Dosing Pump in accordance with the Service Information. Perform HEATER VERIFICATION TEST - VER 1.</p>	All
4	<p>WARNING: NEVER OPERATE THE HEATER IN AN ENCLOSED AREA THAT DOES NOT HAVE EXHAUST VENTILATION FACILITIES. ALWAYS VENT THE EXHAUST WHEN OPERATING THE HEATER. FAILURE TO FOLLOW THESE INSTRUCTIONS CAN RESULT IN PERSONAL INJURY OR DEATH.</p> <p>WARNING: ALLOW THE HEATER ASSEMBLY TO COOL BEFORE PERFORMING A COMPONENT INSPECTION/REPAIR/REPLACEMENT. FAILURE TO FOLLOW THESE INSTRUCTIONS CAN RESULT IN PERSONAL INJURY OR DEATH.</p> <p>Turn the ignition off.</p> <p>Inspect the heater's air intake pipe and exhaust pipe for restrictions and obstructions.</p> <p>Is the heater's air intake pipe and exhaust pipe Ok?</p> <p>Yes → Replace the Cabin Heater Assembly or Heater Booster Assembly in accordance with the Service Information. Perform HEATER VERIFICATION TEST - VER 1.</p> <p>No → Repair the heater's air intake/exhaust as necessary in accordance with the Service Information. Perform HEATER VERIFICATION TEST - VER 1.</p>	All

Symptom List:

FLAME SENSOR OPEN
FLAME SENSOR SHORTED
GLOW PIN OPEN
GLOW PIN SHORTED

**Test Note: All symptoms listed above are diagnosed using the same tests.
The title for the tests will be FLAME SENSOR OPEN.**

When Monitored and Set Condition:**FLAME SENSOR OPEN**

When Monitored: During heater activation and operation.

Set Condition: This DTC will set if the Flame Sensor's resistance is not within the expected parameters.

FLAME SENSOR SHORTED

When Monitored: During heater activation and operation.

Set Condition: This DTC will set if the Flame Sensor's resistance is not within the expected parameters.

GLOW PIN OPEN

When Monitored: During heater activation and operation.

Set Condition: This DTC will set if the Glow Pin's resistance is not within the expected parameters.

GLOW PIN SHORTED

When Monitored: During heater activation and operation.

Set Condition: This DTC will set if the Glow Pin's resistance is not within the expected parameters.

POSSIBLE CAUSES

FLAME SENSOR

CABIN HEATER

FLAME SENSOR OPEN — Continued

TEST	ACTION	APPLICABILITY
1	<p>WARNING: NEVER OPERATE THE HEATER IN AN ENCLOSED AREA THAT DOES NOT HAVE EXHAUST VENTILATION FACILITIES. ALWAYS VENT THE EXHAUST WHEN OPERATING THE HEATER. FAILURE TO FOLLOW THESE INSTRUCTIONS CAN RESULT IN PERSONAL INJURY OR DEATH.</p> <p>WARNING: ALLOW THE HEATER ASSEMBLY TO COOL BEFORE PERFORMING A COMPONENT INSPECTION/REPAIR/REPLACEMENT. FAILURE TO FOLLOW THESE INSTRUCTIONS CAN RESULT IN PERSONAL INJURY OR DEATH.</p> <p>CAUTION: DO NOT PERFORM THIS TEST UNLESS DIRECTED HERE BY THE HEATER PRE-TEST. ALWAYS PERFORM THE HEATER PRE-TEST PRIOR TO PERFORMING ANY OTHER TEST FOR THE RESULT TO BE VALID.</p> <p>Turn the ignition off. View repair</p> <p>Repair</p> <p>Replace the Cabin Heater Assembly or Heater Booster Assembly in accordance with the Service Information. Perform HEATER VERIFICATION TEST - VER 1.</p>	All

Symptom List:

HEATER IN LOCKOUT MODE
HEATER OVERHEATED
SUCCESSIVE OVERHEATING

**Test Note: All symptoms listed above are diagnosed using the same tests.
The title for the tests will be HEATER IN LOCKOUT MODE.**

When Monitored and Set Condition:**HEATER IN LOCKOUT MODE**

When Monitored: During heater activation and operation.

Set Condition: This DTC will set if multiple attempts to start the heater have failed or if successive overheating occurs.

HEATER OVERHEATED

When Monitored: After heater activation, when the system is in a steady state of operation.

Set Condition: This DTC will set if the Temperature Sensor's resistance or Overheating Sensor's resistance is not within the expected parameters (coolant temperature in the heater module exceeds 105°C [221°F]).

SUCCESSIVE OVERHEATING

When Monitored: After heater activation, when the system is in a steady state of operation.

Set Condition: This DTC will set if successive overheating occurs.

POSSIBLE CAUSES

CABIN HEATER ASSEMBLY OR HEATER BOOSTER ASSEMBLY
HEATER'S COOLANT HOSES RESTRICTED/LEAKING/DAMAGED
ENGINE'S COOLING SYSTEM FAULT
CABIN HEATER OR HEATER BOOSTER CONTROL UNIT
HEATER OVERHEATED/SUCCESSIVE OVERHEATING CLEARED, ADDITIONAL DTC(S)
PRESENT

HEATER IN LOCKOUT MODE — Continued

TEST	ACTION	APPLICABILITY
1	<p>WARNING: NEVER OPERATE THE HEATER IN AN ENCLOSED AREA THAT DOES NOT HAVE EXHAUST VENTILATION FACILITIES. ALWAYS VENT THE EXHAUST WHEN OPERATING THE HEATER. FAILURE TO FOLLOW THESE INSTRUCTIONS CAN RESULT IN PERSONAL INJURY OR DEATH.</p> <p>WARNING: ALLOW THE HEATER ASSEMBLY TO COOL BEFORE PERFORMING A COMPONENT INSPECTION/REPAIR/REPLACEMENT. FAILURE TO FOLLOW THESE INSTRUCTIONS CAN RESULT IN PERSONAL INJURY OR DEATH.</p> <p>CAUTION: DO NOT PERFORM THIS TEST UNLESS DIRECTED HERE BY THE HEATER PRE-TEST. ALWAYS PERFORM THE HEATER PRE-TEST PRIOR TO PERFORMING ANY OTHER TEST FOR THE RESULT TO BE VALID.</p> <p>Turn the ignition off.</p> <p>NOTE: If there is an internal leak in the heater, a continuous loud chunking or grinding noise may have been heard coming from the assembly during the Pre-test.</p> <p>Check for engine coolant continuously flowing out of the heater's exhaust pipe. Is engine coolant coming out of the heater's exhaust pipe?</p> <p>Yes → Replace the Cabin Heater Assembly or Heater Booster Assembly in accordance with the Service Information. Perform HEATER VERIFICATION TEST - VER 1.</p> <p>No → Go To 2</p>	All
2	<p>WARNING: NEVER OPERATE THE HEATER IN AN ENCLOSED AREA THAT DOES NOT HAVE EXHAUST VENTILATION FACILITIES. ALWAYS VENT THE EXHAUST WHEN OPERATING THE HEATER. FAILURE TO FOLLOW THESE INSTRUCTIONS CAN RESULT IN PERSONAL INJURY OR DEATH.</p> <p>WARNING: ALLOW THE HEATER ASSEMBLY TO COOL BEFORE PERFORMING A COMPONENT INSPECTION/REPAIR/REPLACEMENT. FAILURE TO FOLLOW THESE INSTRUCTIONS CAN RESULT IN PERSONAL INJURY OR DEATH.</p> <p>Turn the ignition off.</p> <p>Inspect the heater's coolant hoses for restrictions, leakage, and damage. Are the heater's coolant hoses Ok?</p> <p>Yes → Go To 3</p> <p>No → Repair the heater's coolant hoses as necessary in accordance with the Service Information. Perform HEATER VERIFICATION TEST - VER 1.</p>	All
3	<p>WARNING: NEVER OPERATE THE HEATER IN AN ENCLOSED AREA THAT DOES NOT HAVE EXHAUST VENTILATION FACILITIES. ALWAYS VENT THE EXHAUST WHEN OPERATING THE HEATER. FAILURE TO FOLLOW THESE INSTRUCTIONS CAN RESULT IN PERSONAL INJURY OR DEATH.</p> <p>Check that the engine's cooling system is operating properly in accordance with the Service Information. Is the engine's cooling system operating properly?</p> <p>Yes → Go To 4</p> <p>No → Repair the engine's cooling system in accordance with the Service Information. Perform HEATER VERIFICATION TEST - VER 1.</p>	All

HEATER IN LOCKOUT MODE — Continued

TEST	ACTION	APPLICABILITY
4	<p>WARNING: NEVER OPERATE THE HEATER IN AN ENCLOSED AREA THAT DOES NOT HAVE EXHAUST VENTILATION FACILITIES. ALWAYS VENT THE EXHAUST WHEN OPERATING THE HEATER. FAILURE TO FOLLOW THESE INSTRUCTIONS CAN RESULT IN PERSONAL INJURY OR DEATH.</p> <p>Refill the cooling system in accordance with the Service Information. Start the engine. Allow the engine to reach normal operating temperature. Turn the engine off. Allow the engine coolant to cool down to a temperature of 50°C (122°F). Start the engine. Allow the engine to reach normal operating temperature. Turn the engine off. View repair</p> <p style="padding-left: 40px;">Repair</p> <p style="padding-left: 80px;">Go To 5</p>	All
5	<p>WARNING: NEVER OPERATE THE HEATER IN AN ENCLOSED AREA THAT DOES NOT HAVE EXHAUST VENTILATION FACILITIES. ALWAYS VENT THE EXHAUST WHEN OPERATING THE HEATER. FAILURE TO FOLLOW THESE INSTRUCTIONS CAN RESULT IN PERSONAL INJURY OR DEATH.</p> <p>NOTE: The heater's control unit will store up to five DTCs in its memory. NOTE: If the heater's control unit detects a new fault in the system, one that is not already stored in its memory, it will clear the oldest of the five stored DTCs, and it will store the new fault's DTC. NOTE: If the heater's control unit detects a reoccurrence of a stored fault, it will overwrite that fault's DTC with the most recent occurrence.</p> <p>Turn the ignition on. Verify that the Cabin Heater or Heater Booster is switched off. Set the blend control to the max heat position and the mode control to the floor position. Start the engine. Allow the engine to idle. With the DRBIII, monitor for Cabin Heater or Heater Booster Module DTCs while performing the following step. NOTE: Do not disconnect the vehicle's battery or the heater's main power supply while the heater is in operation or in run-down mode. Failure to follow these instructions can result in excess emissions from the heater during heater operation. Switch the Cabin Heater or Heater Booster on. If necessary, allow the heater to run through at least one cycle of operation (approximately 10 minutes), and then turn the heater off. Turn the engine off. Does the DRBIII® display any DTCs?</p> <p style="padding-left: 40px;">Overheating Related DTC(s) Reset Replace the Cabin Heater Assembly or Heater Booster Assembly in accordance with the Service Information. Perform HEATER VERIFICATION TEST - VER 1.</p> <p style="padding-left: 40px;">Ovrheatng DTC(s) clear, Other DTC(s) Set Return to the symptom list and choose the symptom(s). Perform HEATER VERIFICATION TEST - VER 1.</p> <p style="padding-left: 40px;">No DTCs Present Test Complete.</p>	All

CABIN HEATER

Symptom: OVER VOLTAGE

When Monitored and Set Condition:

OVER VOLTAGE

When Monitored: With the engine running.

Set Condition: This DTC will set if the heater's power supply exceed 15.9 volts for longer than 20 seconds.

POSSIBLE CAUSES

VEHICLE'S CHARGING SYSTEM OVERCHARGING

CABIN HEATER OR HEATER BOOSTER CONTROL UNIT

TEST	ACTION	APPLICABILITY
1	<p>WARNING: NEVER OPERATE THE HEATER IN AN ENCLOSED AREA THAT DOES NOT HAVE EXHAUST VENTILATION FACILITIES. ALWAYS VENT THE EXHAUST WHEN OPERATING THE HEATER. FAILURE TO FOLLOW THESE INSTRUCTIONS CAN RESULT IN PERSONAL INJURY OR DEATH.</p> <p>WARNING: ALLOW THE HEATER ASSEMBLY TO COOL BEFORE PERFORMING A COMPONENT INSPECTION/REPAIR/REPLACEMENT. FAILURE TO FOLLOW THESE INSTRUCTIONS CAN RESULT IN PERSONAL INJURY OR DEATH.</p> <p>CAUTION: DO NOT PERFORM THIS TEST UNLESS DIRECTED HERE BY THE HEATER PRE-TEST. ALWAYS PERFORM THE HEATER PRE-TEST PRIOR TO PERFORMING ANY OTHER TEST FOR THE RESULT TO BE VALID.</p> <p>Check the vehicle's charging system for proper operation in accordance with the Service Information.</p> <p>Is the vehicle's charging system operating properly?</p> <p>Yes → Replace the Cabin Heater Assembly or Heater Booster Assembly in accordance with the Service Information. Perform HEATER VERIFICATION TEST - VER 1.</p> <p>No → Repair the vehicle's charging system in accordance with the Service Information. Perform HEATER VERIFICATION TEST - VER 1.</p>	All

Symptom List:

**OVERHEATING SENSOR OPEN
OVERHEATING SENSOR SHORTED**

**Test Note: All symptoms listed above are diagnosed using the same tests.
The title for the tests will be OVERHEATING SENSOR OPEN.**

When Monitored and Set Condition:

OVERHEATING SENSOR OPEN

When Monitored: During heater activation and operation.

Set Condition: This DTC will set if the Overheating Sensor's resistance is not within the expected parameters.

OVERHEATING SENSOR SHORTED

When Monitored: During heater activation and operation.

Set Condition: This DTC will set if the Overheating Sensor's resistance is not within the expected parameters.

POSSIBLE CAUSES

OVERHEATING SENSOR

TEST	ACTION	APPLICABILITY
1	<p>WARNING: NEVER OPERATE THE HEATER IN AN ENCLOSED AREA THAT DOES NOT HAVE EXHAUST VENTILATION FACILITIES. ALWAYS VENT THE EXHAUST WHEN OPERATING THE HEATER. FAILURE TO FOLLOW THESE INSTRUCTIONS CAN RESULT IN PERSONAL INJURY OR DEATH.</p> <p>WARNING: ALLOW THE HEATER ASSEMBLY TO COOL BEFORE PERFORMING A COMPONENT INSPECTION/REPAIR/REPLACEMENT. FAILURE TO FOLLOW THESE INSTRUCTIONS CAN RESULT IN PERSONAL INJURY OR DEATH.</p> <p>CAUTION: DO NOT PERFORM THIS TEST UNLESS DIRECTED HERE BY THE HEATER PRE-TEST. ALWAYS PERFORM THE HEATER PRE-TEST PRIOR TO PERFORMING ANY OTHER TEST FOR THE RESULT TO BE VALID.</p> <p>Turn the ignition off. View repair</p> <p>Repair</p> <p>Replace the Cabin Heater Assembly or Heater Booster Assembly in accordance with the Service Information. Perform HEATER VERIFICATION TEST - VER 1.</p>	All

CABIN HEATER

Symptom List:

TEMP SENSOR OPEN
TEMP SENSOR SHORTED

Test Note: All symptoms listed above are diagnosed using the same tests. The title for the tests will be TEMP SENSOR OPEN.

When Monitored and Set Condition:

TEMP SENSOR OPEN

When Monitored: During heater activation and operation.

Set Condition: This DTC will set if the Temperature Sensor's resistance is not within the expected parameters.

TEMP SENSOR SHORTED

When Monitored: During heater activation and operation.

Set Condition: This DTC will set if the Temperature Sensor's resistance is not within the expected parameters.

POSSIBLE CAUSES

TEMPERATURE SENSOR

TEST	ACTION	APPLICABILITY
1	<p>WARNING: NEVER OPERATE THE HEATER IN AN ENCLOSED AREA THAT DOES NOT HAVE EXHAUST VENTILATION FACILITIES. ALWAYS VENT THE EXHAUST WHEN OPERATING THE HEATER. FAILURE TO FOLLOW THESE INSTRUCTIONS CAN RESULT IN PERSONAL INJURY OR DEATH.</p> <p>WARNING: ALLOW THE HEATER ASSEMBLY TO COOL BEFORE PERFORMING A COMPONENT INSPECTION/REPAIR/REPLACEMENT. FAILURE TO FOLLOW THESE INSTRUCTIONS CAN RESULT IN PERSONAL INJURY OR DEATH.</p> <p>CAUTION: DO NOT PERFORM THIS TEST UNLESS DIRECTED HERE BY THE HEATER PRE-TEST. ALWAYS PERFORM THE HEATER PRE-TEST PRIOR TO PERFORMING ANY OTHER TEST FOR THE RESULT TO BE VALID.</p> <p>Turn the ignition off. View repair</p> <p>Repair</p> <p>Replace the Cabin Heater Assembly or Heater Booster Assembly in accordance with the Service Information. Perform HEATER VERIFICATION TEST - VER 1.</p>	All

Symptom:
UNDER VOLTAGE

When Monitored and Set Condition:

UNDER VOLTAGE

When Monitored: With the engine running.

Set Condition: This DTC will set if the heater's power supply voltage drops below 10.2 volts for longer than 20 seconds.

POSSIBLE CAUSES

- VEHICLE'S BATTERY SYSTEM
- VEHICLE'S CHARGING SYSTEM NOT OPERATING PROPERLY
- CABIN HEATER OR HEATER BOOSTER CONTROL UNIT
- FUSED B+ CIRCUIT HIGH RESISTANCE
- CABIN HEATER OR HEATER BOOSTER CONTROL UNIT

TEST	ACTION	APPLICABILITY
1	<p>WARNING: NEVER OPERATE THE HEATER IN AN ENCLOSED AREA THAT DOES NOT HAVE EXHAUST VENTILATION FACILITIES. ALWAYS VENT THE EXHAUST WHEN OPERATING THE HEATER. FAILURE TO FOLLOW THESE INSTRUCTIONS CAN RESULT IN PERSONAL INJURY OR DEATH.</p> <p>Turn the ignition off. Inspect the vehicle's battery terminals, cable terminals, and cables for corrosion and damage in accordance with the Service Information. Test the vehicle's battery in accordance with the Service Information. Is the vehicle's battery system Ok?</p> <p style="padding-left: 40px;">Yes → Go To 2</p> <p style="padding-left: 40px;">No → Clean/repair the vehicle's battery system in accordance with the Service Information. Perform HEATER VERIFICATION TEST - VER 1.</p>	All
2	<p>WARNING: NEVER OPERATE THE HEATER IN AN ENCLOSED AREA THAT DOES NOT HAVE EXHAUST VENTILATION FACILITIES. ALWAYS VENT THE EXHAUST WHEN OPERATING THE HEATER. FAILURE TO FOLLOW THESE INSTRUCTIONS CAN RESULT IN PERSONAL INJURY OR DEATH.</p> <p>Check the vehicle's charging system for proper operation in accordance with the Service Information. Is the vehicle's charging system operating properly?</p> <p style="padding-left: 40px;">Yes → Go To 3</p> <p style="padding-left: 40px;">No → Repair the vehicle's charging system in accordance with the Service Information. Perform HEATER VERIFICATION TEST - VER 1.</p>	All

CABIN HEATER

UNDER VOLTAGE — Continued

TEST	ACTION	APPLICABILITY
3	<p>WARNING: NEVER OPERATE THE HEATER IN AN ENCLOSED AREA THAT DOES NOT HAVE EXHAUST VENTILATION FACILITIES. ALWAYS VENT THE EXHAUST WHEN OPERATING THE HEATER. FAILURE TO FOLLOW THESE INSTRUCTIONS CAN RESULT IN PERSONAL INJURY OR DEATH.</p> <p>WARNING: ALLOW THE HEATER ASSEMBLY TO COOL BEFORE PERFORMING A COMPONENT INSPECTION/REPAIR/REPLACEMENT. FAILURE TO FOLLOW THESE INSTRUCTIONS CAN RESULT IN PERSONAL INJURY OR DEATH.</p> <p>Turn the ignition on.</p> <p>With the DRBIII® in Sensors, record the Cabin Heater's or Heater Booster's Operating Voltage.</p> <p>NOTE: Check connectors - Clean/repair as necessary.</p> <p>Disconnect the Cabin Heater or Heater Booster harness connector.</p> <p>Measure the voltage between the Fused B+ circuit and ground.</p> <p>Is there more than 1.0 volt difference between the Operating Voltage and the Fused B+ voltage?</p> <p>Yes → Replace the Cabin Heater Assembly or Heater Booster Assembly in accordance with the Service Information. Perform HEATER VERIFICATION TEST - VER 1.</p> <p>No → Go To 4</p>	All

UNDER VOLTAGE — Continued

TEST	ACTION	APPLICABILITY
4	<p>WARNING: NEVER OPERATE THE HEATER IN AN ENCLOSED AREA THAT DOES NOT HAVE EXHAUST VENTILATION FACILITIES. ALWAYS VENT THE EXHAUST WHEN OPERATING THE HEATER. FAILURE TO FOLLOW THESE INSTRUCTIONS CAN RESULT IN PERSONAL INJURY OR DEATH.</p> <p>WARNING: ALLOW THE HEATER ASSEMBLY TO COOL BEFORE PERFORMING A COMPONENT INSPECTION/REPAIR/REPLACEMENT. FAILURE TO FOLLOW THESE INSTRUCTIONS CAN RESULT IN PERSONAL INJURY OR DEATH.</p> <p>Reconnect the Cabin Heater or Heater Booster harness connector. Connect a suitable voltmeter to the vehicle's battery. Position the voltmeter where it can be monitored while operating the DRBIII®. Turn the ignition on. Set the blend control to the max heat position and the mode control to the floor position. Start the engine. Allow the engine to idle.</p> <p>NOTE: Do not disconnect the vehicle's battery or the heater's main power supply while the heater is in operation or in run-down mode. Failure to follow these instructions can result in excess emissions from the heater during heater operation.</p> <p>Switch the Cabin Heater or Heater Booster on. If necessary, allow the heater to run through at least one cycle of operation (approximately 10 minutes), and then turn the heater off. With the DRBIII® in Sensors, monitor the voltmeter and the Cabin Heater's or Heater Booster's Operating Voltage while the heater is operational. Switch the heater off. Turn the engine off.</p> <p>Was there more than 1.5 volts difference between Operating & battery voltage?</p> <p>Yes → Repair the high resistance in the Fused B+ circuit. Perform HEATER VERIFICATION TEST - VER 1.</p> <p>No → Replace the Cabin Heater Assembly or Heater Booster Assembly in accordance with the Service Information. Perform HEATER VERIFICATION TEST - VER 1.</p>	All

Symptom:

***NO RESPONSE FROM AIRBAG CONTROL MODULE**

POSSIBLE CAUSES
CHECK POWERS AND GROUNDS TO THE AIRBAG CONTROL MODULE K-ACM CIRCUIT SHORTED TO GROUND K-ACM CIRCUIT SHORTED TO VOLTAGE K-ACM CIRCUIT OPEN AIRBAG CONTROL MODULE

TEST	ACTION	APPLICABILITY
1	<p>WARNING: TURN THE IGNITION OFF, DISCONNECT THE BATTERY AND WAIT TWO MINUTES BEFORE PROCEEDING. FAILURE TO DO SO MAY RESULT IN PERSONAL INJURY OR DEATH.</p> <p>Disconnect the Airbag Control Module harness connector. Check each power and ground circuit to the module. Were any problems found?</p> <p style="padding-left: 40px;">Yes → Refer to the wiring diagrams located in the service information to help isolate an open or shorted condition. Repair as necessary. Perform AIRBAG VERIFICATION TEST - VER 1.</p> <p style="padding-left: 40px;">No → Go To 2</p>	All
2	<p>WARNING: TURN THE IGNITION OFF, DISCONNECT THE BATTERY AND WAIT TWO MINUTES BEFORE PROCEEDING. FAILURE TO DO SO MAY RESULT IN PERSONAL INJURY OR DEATH.</p> <p>Disconnect the ACM harness connector. Disconnect the DRBIII® from the DLC. Measure the resistance between ground and the K-ACM circuit. Is the resistance below 5.0 ohms?</p> <p style="padding-left: 40px;">Yes → Repair the K-ACM circuit for a short to ground. Perform AIRBAG VERIFICATION TEST - VER 1.</p> <p style="padding-left: 40px;">No → Go To 3</p>	All
3	<p>WARNING: TURN THE IGNITION OFF, DISCONNECT THE BATTERY AND WAIT TWO MINUTES BEFORE PROCEEDING. FAILURE TO DO SO MAY RESULT IN PERSONAL INJURY OR DEATH.</p> <p>Disconnect the DRBIII® from the DLC. Disconnect the ACM harness connector. Turn the ignition on. Using a 12-volt test light connected to ground, probe the K-ACM circuit. NOTE: The test light must illuminate brightly. Compare the brightness to that of a direct connection to the battery. Does the test light illuminate brightly?</p> <p style="padding-left: 40px;">Yes → Repair the K-ACM circuit for a short to voltage. Perform AIRBAG VERIFICATION TEST - VER 1.</p> <p style="padding-left: 40px;">No → Go To 4</p>	All

***NO RESPONSE FROM AIRBAG CONTROL MODULE — Continued**

TEST	ACTION	APPLICABILITY
<p>4</p>	<p>WARNING: TURN THE IGNITION OFF, DISCONNECT THE BATTERY AND WAIT TWO MINUTES BEFORE PROCEEDING. FAILURE TO DO SO MAY RESULT IN PERSONAL INJURY OR DEATH.</p> <p>Disconnect the ACM harness connector. Disconnect the DRBIII® from the DLC. Measure the resistance of the K-ACM circuit between the ACM connector and the DLC. Is the resistance below 5.0 ohms?</p> <p>Yes → Replace the Airbag Control Module in accordance with the Service Information. Perform AIRBAG VERIFICATION TEST - VER 1.</p> <p>No → Repair the K-ACM circuit for an open. Perform AIRBAG VERIFICATION TEST - VER 1.</p>	<p>All</p>

Symptom:

***NO RESPONSE FROM AUTOMATIC TEMPERATURE CONTROL**

POSSIBLE CAUSES
CHECK POWERS AND GROUNDS TO THE AUTOMATIC TEMPERATURE CONTROL MODULE - INTERNAL SHORT TO GROUND K-IC, ATC, HBM, CHM CIRCUIT SHORTED TO GROUND MODULE - INTERNAL SHORT TO VOLTAGE K-IC, ATC, HBM, CHM CIRCUIT SHORTED TO VOLTAGE K-IC, ATC, HBM, CHM CIRCUIT OPEN AUTOMATIC TEMPERATURE CONTROL

TEST	ACTION	APPLICABILITY
1	Turn the ignition off. Disconnect the Automatic Temperature Control harness connectors. Check each power and ground circuit to the module. Were any problems found? Yes → Refer to the wiring diagrams located in the service information to help isolate an open or shorted condition. Repair as necessary. Perform BODY VERIFICATION TEST - VER 1. No → Go To 2	All
2	Turn the ignition off. Disconnect the Automatic Temperature Control harness connectors. Disconnect the DRBIII® from the DLC. Measure the resistance between ground and the K-IC, ATC, HBM, CHM circuit. Is the resistance below 5.0 ohms? Yes → Go To 3 No → Go To 4	All
3	Turn the ignition off. Disconnect the Automatic Temperature Control harness connectors. Measure the resistance between ground and the K-IC, ATC, HBM, CHM circuit. While monitoring the ohmmeter, disconnect each module (IC, HBM, CHM) one at a time. NOTE: The vehicle may not be equipped with all the above modules. Is the resistance below 5.0 ohms with all the above modules disconnected? Yes → Repair the K-IC, ATC, HBM, CHM circuit for a short to ground. Perform BODY VERIFICATION TEST - VER 1. No → Replace the Module, that when disconnected the short was eliminated, in accordance with the service information. Perform BODY VERIFICATION TEST - VER 1.	All

***NO RESPONSE FROM AUTOMATIC TEMPERATURE CONTROL —
Continued**

TEST	ACTION	APPLICABILITY
4	<p>Turn the ignition off. Disconnect the DRBIII® from the DLC. Disconnect the Automatic Temperature Control harness connectors. Turn the ignition on. Using a 12-volt test light connected to ground, probe the K-IC, ATC, HBM, CHM circuit. NOTE: The test light must illuminate brightly. Compare the brightness to that of a direct connection to the battery. Does the test light illuminate brightly?</p> <p>Yes → Go To 5 No → Go To 6</p>	All
5	<p>Turn the ignition off. Disconnect the Automatic Temperature Control harness connectors. Turn the ignition on. Using a 12-volt test light connected to ground, probe the K-IC, ATC, HBM, CHM circuit. While monitoring the test light, disconnect each module (IC, HBM, CHM) one at a time. NOTE: The vehicle may not be equipped with all the above modules. NOTE: The test light must illuminate brightly. Compare the brightness to that of a direct connection to the battery. Does the test light illuminate brightly with all the above modules disconnected?</p> <p>Yes → Repair the K-IC, ATC, HBM, CHM circuit for a short to voltage. Perform BODY VERIFICATION TEST - VER 1.</p> <p>No → Replace the Module, that when disconnected the short was eliminated, in accordance with the service information. Perform BODY VERIFICATION TEST - VER 1.</p>	All
6	<p>Turn the ignition off. Disconnect the Automatic Temperature Control harness connectors. Disconnect the DRBIII® from the DLC. Measure the resistance of the K-IC, ATC, HBM, CHM circuit between the ATC connector and the DLC. Is the resistance below 5.0 ohms?</p> <p>Yes → Replace the Automatic Temperature Control in accordance with the Service Information. Perform BODY VERIFICATION TEST - VER 1.</p> <p>No → Repair the K-IC, ATC, HBM, CHM circuit for an open. Perform BODY VERIFICATION TEST - VER 1.</p>	All

Symptom:

***NO RESPONSE FROM CABIN HEATER MODULE**

POSSIBLE CAUSES
CHECK POWERS AND GROUNDS TO THE CABIN HEATER MODULE
MODULE - INTERNAL SHORT TO GROUND
K-IC, ATC, HBM, CHM CIRCUIT SHORTED TO GROUND
MODULE - INTERNAL SHORT TO VOLTAGE
K-IC, ATC, HBM, CHM CIRCUIT SHORTED TO VOLTAGE
K-IC, ATC, HBM, CHM CIRCUIT OPEN
CABIN HEATER MODULE

TEST	ACTION	APPLICABILITY
1	Turn the ignition off. Disconnect the Cabin Heater Module harness connectors. Check each power and ground circuit to the module. Were any problems found? Yes → Refer to the wiring diagrams located in the service information to help isolate an open or shorted condition. Repair as necessary. Perform BODY VERIFICATION TEST - VER 1. No → Go To 2	All
2	Turn the ignition off. Disconnect the Cabin Heater Module harness connectors. Disconnect the DRBIII® from the DLC. Measure the resistance between ground and the K-IC, ATC, HBM, CHM circuit. Is the resistance below 5.0 ohms? Yes → Go To 3 No → Go To 4	All
3	Turn the ignition off. Disconnect the Cabin Heater Module harness connectors. Measure the resistance between ground and the K-IC, ATC, HBM, CHM circuit. While monitoring the ohmmeter, disconnect each module (IC, ATC, HBM) one at a time. NOTE: The vehicle may not be equipped with all the above modules. Is the resistance below 5.0 ohms with all the above modules disconnected? Yes → Repair the K-IC, ATC, HBM, CHM circuit for a short to ground. Perform BODY VERIFICATION TEST - VER 1. No → Replace the Module, that when disconnected the short was eliminated, in accordance with the service information. Perform BODY VERIFICATION TEST - VER 1.	All

***NO RESPONSE FROM CABIN HEATER MODULE — Continued**

TEST	ACTION	APPLICABILITY
4	Turn the ignition off. Disconnect the DRBIII® from the DLC. Disconnect the Cabin Heater Module harness connectors. Turn the ignition on. Using a 12-volt test light connected to ground, probe the K-IC, ATC, HBM, CHM circuit. NOTE: The test light must illuminate brightly. Compare the brightness to that of a direct connection to the battery. Does the test light illuminate brightly? Yes → Go To 5 No → Go To 6	All
5	Turn the ignition off. Disconnect the Cabin Heater Module harness connectors. Turn the ignition on. Using a 12-volt test light connected to ground, probe the K-IC, ATC, HBM, CHM circuit. While monitoring the test light, disconnect each module (IC, ATC, HBM) one at a time. NOTE: The vehicle may not be equipped with all the above modules. NOTE: The test light must illuminate brightly. Compare the brightness to that of a direct connection to the battery. Does the test light illuminate brightly with all the above modules disconnected? Yes → Repair the K-IC, ATC, HBM, CHM circuit for a short to voltage. Perform BODY VERIFICATION TEST - VER 1. No → Replace the Module, that when disconnected the short was eliminated, in accordance with the service information. Perform BODY VERIFICATION TEST - VER 1.	All
6	Turn the ignition off. Disconnect the Cabin Heater Module harness connectors. Disconnect the DRBIII® from the DLC. Measure the resistance of the K-IC, ATC, HBM, CHM circuit between the CHM connector and the DLC. Is the resistance below 5.0 ohms? Yes → Replace the Cabin Heater Module in accordance with the Service Information. Perform BODY VERIFICATION TEST - VER 1. No → Repair the K-IC, ATC, HBM, CHM circuit for an open. Perform BODY VERIFICATION TEST - VER 1.	All

Symptom:

***NO RESPONSE FROM CENTRAL TIMER MODULE**

POSSIBLE CAUSES
CHECK POWERS AND GROUNDS TO THE CENTRAL TIMER MODULE
SECURITY SYSTEM MODULE
K-CTM, SSM CIRCUIT SHORTED TO GROUND
SECURITY SYSTEM MODULE
K-CTM, SSM CIRCUIT SHORTED TO VOLTAGE
K-CTM, SSM CIRCUIT OPEN
CENTRAL TIMER MODULE

TEST	ACTION	APPLICABILITY
1	Turn the ignition off. Disconnect the Central Timer Module harness connectors. Check each power and ground circuit to the module. Were any problems found? Yes → Refer to the wiring diagrams located in the service information to help isolate an open or shorted condition. Repair as necessary. Perform BODY VERIFICATION TEST - VER 1. No → Go To 2	All
2	Turn the ignition off. Disconnect the CTM harness connectors. Disconnect the DRBIII® from the DLC. Measure the resistance between ground and the K-CTM, SSM circuit. Is the resistance below 5.0 ohms? Yes → Go To 3 No → Go To 4	All
3	Turn the ignition off. Disconnect the Security System Module harness connector. Measure the resistance between ground and the K-CTM, SSM circuit. Is the resistance below 5.0 ohms? Yes → Repair the K-CTM, SSM circuit for a short to ground. Perform BODY VERIFICATION TEST - VER 1. No → Replace the Security System Module in accordance with the service information. Perform BODY VERIFICATION TEST - VER 1.	All

***NO RESPONSE FROM CENTRAL TIMER MODULE — Continued**

TEST	ACTION	APPLICABILITY
4	Turn the ignition off. Disconnect the DRBIII® from the DLC. Disconnect the CTM harness connectors. Turn the ignition on. Using a 12-volt test light connected to ground, probe the K-CTM, SSM circuit. NOTE: The test light must illuminate brightly. Compare the brightness to that of a direct connection to the battery. Does the test light illuminate brightly? Yes → Go To 5 No → Go To 6	All
5	Turn the ignition off. Disconnect the Security System Module harness connector. Turn the ignition on. Using a 12-volt test light connected to ground, probe the K-CTM, SSM circuit. NOTE: The test light must illuminate brightly. Compare the brightness to that of a direct connection to the battery. Does the test light illuminate brightly? Yes → Repair the K-CTM, SSM circuit for a short to voltage. Perform BODY VERIFICATION TEST - VER 1. No → Replace the Security System Module in accordance with the service information. Perform BODY VERIFICATION TEST - VER 1.	All
6	Turn the ignition off. Disconnect the CTM harness connectors. Disconnect the DRBIII® from the DLC. Measure the resistance of the K-CTM, SSM circuit between the CTM connector and the DLC. Is the resistance below 5.0 ohms? Yes → Replace the Central Timer Module in accordance with the Service Information. Perform BODY VERIFICATION TEST - VER 1. No → Repair the K-CTM, SSM circuit for an open. Perform BODY VERIFICATION TEST - VER 1.	All

Symptom:

***NO RESPONSE FROM CONTROLLER ANTILOCK BRAKE**

POSSIBLE CAUSES
CHECK POWERS AND GROUNDS TO THE CONTROLLER ANTILOCK BRAKE SHIFTER ASSEMBLY K-ABS, SHIFTER ASSEMBLY CIRCUIT SHORTED TO GROUND SHIFTER ASSEMBLY K-ABS, SHIFTER ASSEMBLY CIRCUIT SHORTED TO VOLTAGE K-ABS, SHIFTER ASSEMBLY CIRCUIT OPEN CONTROLLER ANTILOCK BRAKE

TEST	ACTION	APPLICABILITY
1	Turn the ignition off. Disconnect the Controller Antilock Brake harness connector. Check each power and ground circuit to the module. Were any problems found? Yes → Refer to the wiring diagrams located in the service information to help isolate an open or shorted condition. Repair as necessary. Perform ABS VERIFICATION TEST - VER 1. No → Go To 2	All
2	Turn the ignition off. Disconnect the CAB harness connector. Disconnect the DRBIII® from the DLC. Measure the resistance between ground and the K-ABS, Shifter Assembly circuit. Is the resistance below 5.0 ohms? Yes → Go To 3 No → Go To 4	All
3	Turn the ignition off. Disconnect the Shifter Assembly harness connector. Measure the resistance between ground and the K-ABS, Shifter Assembly circuit. Is the resistance below 5.0 ohms? Yes → Repair the K-ABS, Shifter Assembly circuit for a short to ground. Perform ABS VERIFICATION TEST - VER 1. No → Replace the Shifter Assembly in accordance with the service information. Perform ABS VERIFICATION TEST - VER 1.	All

***NO RESPONSE FROM CONTROLLER ANTILOCK BRAKE — Continued**

TEST	ACTION	APPLICABILITY
4	Turn the ignition off. Disconnect the DRBIII® from the DLC. Disconnect the CAB harness connector. Turn the ignition on. Using a 12-volt test light connected to ground, probe the K-ABS, Shifter Assembly circuit. NOTE: The test light must illuminate brightly. Compare the brightness to that of a direct connection to the battery. Does the test light illuminate brightly? Yes → Go To 5 No → Go To 6	All
5	Turn the ignition off. Disconnect the Shifter Assembly harness connector. Turn the ignition on. Using a 12-volt test light connected to ground, probe the K-ABS, Shifter Assembly circuit. NOTE: The test light must illuminate brightly. Compare the brightness to that of a direct connection to the battery. Does the test light illuminate brightly? Yes → Repair the K-ABS, Shifter Assembly circuit for a short to voltage. Perform ABS VERIFICATION TEST - VER 1. No → Replace the Shifter Assembly in accordance with the service information. Perform ABS VERIFICATION TEST - VER 1.	All
6	Turn the ignition off. Disconnect the CAB harness connector. Disconnect the DRBIII® from the DLC. Measure the resistance of the K-ABS, Shifter Assembly circuit between the CAB connector and the DLC. Is the resistance below 5.0 ohms? Yes → Replace the Controller Antilock Brake in accordance with the Service Information. Perform ABS VERIFICATION TEST - VER 1. No → Repair the K-ABS, Shifter Assembly circuit for an open. Perform ABS VERIFICATION TEST - VER 1.	All

Symptom:

***NO RESPONSE FROM ENGINE CONTROL MODULE**

POSSIBLE CAUSES
CHECK POWERS AND GROUNDS TO THE ENGINE CONTROL MODULE K-ECM CIRCUIT SHORTED TO GROUND K-ECM CIRCUIT SHORTED TO VOLTAGE K-ECM CIRCUIT OPEN ENGINE CONTROL MODULE

TEST	ACTION	APPLICABILITY
1	Turn the ignition off. Disconnect the Engine Control Module harness connectors. Check each power and ground circuit to the module. Were any problems found? Yes → Refer to the wiring diagrams located in the service information to help isolate an open or shorted condition. Repair as necessary. Perform ROAD TEST VERIFICATION - VER-2. No → Go To 2	All
2	Turn the ignition off. Disconnect the ECM harness connectors. Disconnect the DRBIII® from the DLC. Measure the resistance between ground and the K-ECM circuit. Is the resistance below 5.0 ohms? Yes → Repair the K-ECM circuit for a short to ground. Perform ROAD TEST VERIFICATION - VER-2. No → Go To 3	All
3	Turn the ignition off. Disconnect the DRBIII® from the DLC. Disconnect the ECM harness connectors. Turn the ignition on. Using a 12-volt test light connected to ground, probe the K-ECM circuit. NOTE: The test light must illuminate brightly. Compare the brightness to that of a direct connection to the battery. Does the test light illuminate brightly? Yes → Repair the K-ECM circuit for a short to voltage. Perform ROAD TEST VERIFICATION - VER-2. No → Go To 4	All

***NO RESPONSE FROM ENGINE CONTROL MODULE — Continued**

TEST	ACTION	APPLICABILITY
4	<p>Turn the ignition off. Disconnect the ECM harness connectors. Disconnect the DRBIII® from the DLC. Measure the resistance of the K-ECM circuit between the ECM connector and the DLC. Is the resistance below 5.0 ohms?</p> <p>Yes → Replace and program the Engine Control Module in accordance with the Service Information. Perform ROAD TEST VERIFICATION - VER-2.</p> <p>No → Repair the K-ECM circuit for an open. Perform ROAD TEST VERIFICATION - VER-2.</p>	All

Symptom:

***NO RESPONSE FROM HEATER BOOSTER MODULE**

POSSIBLE CAUSES
CHECK POWERS AND GROUNDS TO THE HEATER BOOSTER MODULE
MODULE - INTERNAL SHORT TO GROUND
K-IC, ATC, HBM, CHM CIRCUIT SHORTED TO GROUND
MODULE - INTERNAL SHORT TO VOLTAGE
K-IC, ATC, HBM, CHM CIRCUIT SHORTED TO VOLTAGE
K-IC, ATC, HBM, CHM CIRCUIT OPEN
HEATER BOOSTER MODULE

TEST	ACTION	APPLICABILITY
1	Turn the ignition off. Disconnect the Heater Booster Module harness connector. Check each power and ground circuit to the module. Were any problems found? Yes → Refer to the wiring diagrams located in the service information to help isolate an open or shorted condition. Repair as necessary. Perform BODY VERIFICATION TEST - VER 1. No → Go To 2	All
2	Turn the ignition off. Disconnect the Heater Booster Module harness connector. Disconnect the DRBIII® from the DLC. Measure the resistance between ground and the K-IC, ATC, HBM, CHM circuit. Is the resistance below 5.0 ohms? Yes → Go To 3 No → Go To 4	All
3	Turn the ignition off. Disconnect the Heater Booster Module harness connector. Measure the resistance between ground and the K-IC, ATC, HBM, CHM circuit. While monitoring the ohmmeter, disconnect each module (IC, ATC, CHM) one at a time. NOTE: The vehicle may not be equipped with all the above modules. Is the resistance below 5.0 ohms with all the above modules disconnected? Yes → Repair the K-IC, ATC, HBM, CHM circuit for a short to ground. Perform BODY VERIFICATION TEST - VER 1. No → Replace the Module, that when disconnected the short was eliminated, in accordance with the service information. Perform BODY VERIFICATION TEST - VER 1.	All

***NO RESPONSE FROM HEATER BOOSTER MODULE — Continued**

TEST	ACTION	APPLICABILITY
4	Turn the ignition off. Disconnect the DRBIII® from the DLC. Disconnect the Heater Booster Module harness connector. Turn the ignition on. Using a 12-volt test light connected to ground, probe the K-IC, ATC, HBM, CHM circuit. NOTE: The test light must illuminate brightly. Compare the brightness to that of a direct connection to the battery. Does the test light illuminate brightly? Yes → Go To 5 No → Go To 6	All
5	Turn the ignition off. Disconnect the Heater Booster Module harness connector. Turn the ignition on. Using a 12-volt test light connected to ground, probe the K-IC, ATC, HBM, CHM circuit. While monitoring the test light, disconnect each module (IC, ATC, CHM) one at a time. NOTE: The vehicle may not be equipped with all the above modules. NOTE: The test light must illuminate brightly. Compare the brightness to that of a direct connection to the battery. Does the test light illuminate brightly with all the above modules disconnected? Yes → Repair the K-IC, ATC, HBM, CHM circuit for a short to voltage. Perform BODY VERIFICATION TEST - VER 1. No → Replace the Module, that when disconnected the short was eliminated, in accordance with the service information. Perform BODY VERIFICATION TEST - VER 1.	All
6	Turn the ignition off. Disconnect the Heater Booster Module harness connector. Disconnect the DRBIII® from the DLC. Measure the resistance of the K-IC, ATC, HBM, CHM circuit between the HBM connector and the DLC. Is the resistance below 5.0 ohms? Yes → Replace the Heater Booster Module in accordance with the Service Information. Perform BODY VERIFICATION TEST - VER 1. No → Repair the K-IC, ATC, HBM, CHM circuit for an open. Perform BODY VERIFICATION TEST - VER 1.	All

Symptom:

***NO RESPONSE FROM INSTRUMENT CLUSTER**

POSSIBLE CAUSES
CHECK POWERS AND GROUNDS TO THE INSTRUMENT CLUSTER MODULE - INTERNAL SHORT TO GROUND K-IC, ATC, HBM, CHM CIRCUIT SHORTED TO GROUND MODULE - INTERNAL SHORT TO VOLTAGE K-IC, ATC, HBM, CHM CIRCUIT SHORTED TO VOLTAGE K-IC, ATC, HBM, CHM CIRCUIT OPEN INSTRUMENT CLUSTER

TEST	ACTION	APPLICABILITY
1	Turn the ignition off. Disconnect the Instrument Cluster harness connectors. Check each power and ground circuit to the module. Were any problems found? Yes → Refer to the wiring diagrams located in the service information to help isolate an open or shorted condition. Repair as necessary. Perform BODY VERIFICATION TEST - VER 1. No → Go To 2	All
2	Turn the ignition off. Disconnect the Instrument Cluster harness connectors. Disconnect the DRBIII® from the DLC. Measure the resistance between ground and the K-IC, ATC, HBM, CHM circuit. Is the resistance below 5.0 ohms? Yes → Go To 3 No → Go To 4	All
3	Turn the ignition off. Disconnect the Instrument Cluster harness connectors. Measure the resistance between ground and the K-IC, ATC, HBM, CHM circuit. While monitoring the ohmmeter, disconnect each module (ATC, HBM, CHM) one at a time. NOTE: The vehicle may not be equipped with all the above modules. Is the resistance below 5.0 ohms with all the above modules disconnected? Yes → Repair the K-IC, ATC, HBM, CHM circuit for a short to ground. Perform BODY VERIFICATION TEST - VER 1. No → Replace the Module, that when disconnected the short was eliminated, in accordance with the service information. Perform BODY VERIFICATION TEST - VER 1.	All

***NO RESPONSE FROM INSTRUMENT CLUSTER — Continued**

TEST	ACTION	APPLICABILITY
4	<p>Turn the ignition off. Disconnect the DRBIII® from the DLC. Disconnect the Instrument Cluster harness connectors. Turn the ignition on. Using a 12-volt test light connected to ground, probe the K-IC, ATC, HBM, CHM circuit. NOTE: The test light must illuminate brightly. Compare the brightness to that of a direct connection to the battery. Does the test light illuminate brightly?</p> <p style="padding-left: 40px;">Yes → Go To 5</p> <p style="padding-left: 40px;">No → Go To 6</p>	All
5	<p>Turn the ignition off. Disconnect the Instrument Cluster harness connectors. Turn the ignition on. Using a 12-volt test light connected to ground, probe the K-IC, ATC, HBM, CHM circuit. While monitoring the test light, disconnect each module (ATC, HBM, CHM) one at a time. NOTE: The vehicle may not be equipped with all the above modules. NOTE: The test light must illuminate brightly. Compare the brightness to that of a direct connection to the battery. Does the test light illuminate brightly with all the above modules disconnected?</p> <p style="padding-left: 40px;">Yes → Repair the K-IC, ATC, HBM, CHM circuit for a short to voltage. Perform BODY VERIFICATION TEST - VER 1.</p> <p style="padding-left: 40px;">No → Replace the Module, that when disconnected the short was eliminated, in accordance with the service information. Perform BODY VERIFICATION TEST - VER 1.</p>	All
6	<p>Turn the ignition off. Disconnect the Instrument Cluster harness connectors. Disconnect the DRBIII® from the DLC. Measure the resistance of the K-IC, ATC, HBM, CHM circuit between the Instrument Cluster connector and the DLC. Is the resistance below 5.0 ohms?</p> <p style="padding-left: 40px;">Yes → Replace the Instrument Cluster in accordance with the Service Information. Perform BODY VERIFICATION TEST - VER 1.</p> <p style="padding-left: 40px;">No → Repair the K-IC, ATC, HBM, CHM circuit for an open. Perform BODY VERIFICATION TEST - VER 1.</p>	All

Symptom:

***NO RESPONSE FROM SECURITY SYSTEM MODULE**

POSSIBLE CAUSES
CHECK POWERS AND GROUNDS TO THE SECURITY SYSTEM MODULE CENTRAL TIMER MODULE K-CTM, SSM CIRCUIT SHORTED TO GROUND CENTRAL TIMER MODULE K-CTM, SSM CIRCUIT SHORTED TO VOLTAGE K-CTM, SSM CIRCUIT OPEN SECURITY SYSTEM MODULE

TEST	ACTION	APPLICABILITY
1	Turn the ignition off. Disconnect the Security System Module harness connectors. Check each power and ground circuit to the module. Were any problems found? Yes → Refer to the wiring diagrams located in the service information to help isolate an open or shorted condition. Repair as necessary. Perform BODY VERIFICATION TEST - VER 1. No → Go To 2	All
2	Turn the ignition off. Disconnect the SSM harness connectors. Disconnect the DRBIII® from the DLC. Measure the resistance between ground and the K-CTM, SSM circuit. Is the resistance below 5.0 ohms? Yes → Go To 3 No → Go To 4	All
3	Turn the ignition off. Disconnect the Central Timer Module harness connector. Measure the resistance between ground and the K-CTM, SSM circuit. Is the resistance below 5.0 ohms? Yes → Repair the K-CTM, SSM circuit for a short to ground. Perform BODY VERIFICATION TEST - VER 1. No → Replace the Central Timer Module in accordance with the service information. Perform BODY VERIFICATION TEST - VER 1.	All

***NO RESPONSE FROM SECURITY SYSTEM MODULE — Continued**

TEST	ACTION	APPLICABILITY
4	Turn the ignition off. Disconnect the DRBIII® from the DLC. Disconnect the SSM harness connectors. Turn the ignition on. Using a 12-volt test light connected to ground, probe the K-CTM, SSM circuit. NOTE: The test light must illuminate brightly. Compare the brightness to that of a direct connection to the battery. Does the test light illuminate brightly? Yes → Go To 5 No → Go To 6	All
5	Turn the ignition off. Disconnect the Central Timer Module harness connectors. Turn the ignition on. Using a 12-volt test light connected to ground, probe the K-CTM, SSM circuit. NOTE: The test light must illuminate brightly. Compare the brightness to that of a direct connection to the battery. Does the test light illuminate brightly? Yes → Repair the K-CTM, SSM circuit for a short to voltage. Perform BODY VERIFICATION TEST - VER 1. No → Replace the Central Timer Module in accordance with the service information. Perform BODY VERIFICATION TEST - VER 1.	All
6	Turn the ignition off. Disconnect the SSM harness connectors. Disconnect the DRBIII® from the DLC. Measure the resistance of the K-CTM, SSM circuit between the SSM connector and the DLC. Is the resistance below 5.0 ohms? Yes → Replace the Security System Module in accordance with the Service Information. Perform BODY VERIFICATION TEST - VER 1. No → Repair the K-CTM, SSM circuit for an open. Perform BODY VERIFICATION TEST - VER 1.	All

Symptom:

***NO RESPONSE FROM SENTRY KEY REMOTE ENTRY MODULE**

POSSIBLE CAUSES
CHECK POWERS AND GROUNDS TO THE SENTRY KEY REMOTE ENTRY MODULE
K-SKREEM CIRCUIT SHORTED TO GROUND
K-SKREEM CIRCUIT SHORTED TO VOLTAGE
K-SKREEM CIRCUIT OPEN
SENTRY KEY REMOTE ENTRY MODULE

TEST	ACTION	APPLICABILITY
1	Turn the ignition off. Disconnect the SKREEM harness connector. Check each power and ground circuit to the module. Were any problems found? Yes → Refer to the wiring diagrams located in the service information to help isolate an open or shorted condition. Repair as necessary. Perform BODY VERIFICATION TEST - VER 1. No → Go To 2	All
2	Turn the ignition off. Disconnect the SKREEM harness connector. Disconnect the DRBIII® from the DLC. Measure the resistance between ground and the K-SKREEM circuit. Is the resistance below 5.0 ohms? Yes → Repair the K-SKREEM circuit for a short to ground. Perform BODY VERIFICATION TEST - VER 1. No → Go To 3	All
3	Turn the ignition off. Disconnect the DRBIII® from the DLC. Disconnect the SKREEM harness connector. Turn the ignition on. Using a 12-volt test light connected to ground, probe the K-SKREEM circuit. NOTE: The test light must illuminate brightly. Compare the brightness to that of a direct connection to the battery. Does the test light illuminate brightly? Yes → Repair the K-SKREEM circuit for a short to voltage. Perform BODY VERIFICATION TEST - VER 1. No → Go To 4	All

***NO RESPONSE FROM SENTRY KEY REMOTE ENTRY MODULE —
Continued**

TEST	ACTION	APPLICABILITY
4	Turn the ignition off. Disconnect the SKREEM harness connector. Disconnect the DRBIII® from the DLC. Measure the resistance of the K-SKREEM circuit between the SKREEM connector and the DLC. Is the resistance below 5.0 ohms? Yes → Replace and program the Sentry Key Remote Entry Module in accordance with the Service Information. Perform BODY VERIFICATION TEST - VER 1. No → Repair the K-SKREEM circuit for an open. Perform BODY VERIFICATION TEST - VER 1.	All

Symptom:

***NO RESPONSE FROM SHIFTER ASSEMBLY**

POSSIBLE CAUSES
CHECK POWERS AND GROUNDS TO THE SHIFTER ASSEMBLY CONTROLLER ANTILOCK BRAKE K-ABS, SHIFTER ASSEMBLY CIRCUIT SHORTED TO GROUND CONTROLLER ANTILOCK BRAKE K-ABS, SHIFTER ASSEMBLY CIRCUIT SHORTED TO VOLTAGE K-ABS, SHIFTER ASSEMBLY CIRCUIT OPEN SHIFTER ASSEMBLY

TEST	ACTION	APPLICABILITY
1	Turn the ignition off. Disconnect the Shifter Assembly harness connector. Check each power and ground circuit to the module. Were any problems found? Yes → Refer to the wiring diagrams located in the service information to help isolate an open or shorted condition. Repair as necessary. Perform NAG1 TRANSMISSION VERIFICATION TEST - VER 1. No → Go To 2	All
2	Turn the ignition off. Disconnect the Shifter Assembly harness connector. Disconnect the DRBIII® from the DLC. Measure the resistance between ground and the K-ABS, Shifter Assembly circuit. Is the resistance below 5.0 ohms? Yes → Go To 3 No → Go To 4	All
3	Turn the ignition off. Disconnect the CAB harness connector. Measure the resistance between ground and the K-ABS, Shifter Assembly circuit. Is the resistance below 5.0 ohms? Yes → Repair the K-ABS, Shifter Assembly circuit for a short to ground. Perform NAG1 TRANSMISSION VERIFICATION TEST - VER 1. No → Replace the Controller Antilock Brake in accordance with the service information. Perform NAG1 TRANSMISSION VERIFICATION TEST - VER 1.	All

***NO RESPONSE FROM SHIFTER ASSEMBLY — Continued**

TEST	ACTION	APPLICABILITY
4	Turn the ignition off. Disconnect the DRBIII® from the DLC. Disconnect the Shifter Assembly harness connector. Turn the ignition on. Using a 12-volt test light connected to ground, probe the K-ABS, Shifter Assembly circuit. NOTE: The test light must illuminate brightly. Compare the brightness to that of a direct connection to the battery. Does the test light illuminate brightly? Yes → Go To 5 No → Go To 6	All
5	Turn the ignition off. Disconnect the Controller Antilock Brake harness connector. Turn the ignition on. Using a 12-volt test light connected to ground, probe the K-ABS, Shifter Assembly circuit. NOTE: The test light must illuminate brightly. Compare the brightness to that of a direct connection to the battery. Does the test light illuminate brightly? Yes → Repair the K-ABS, Shifter Assembly circuit for a short to voltage. Perform NAG1 TRANSMISSION VERIFICATION TEST - VER 1. No → Replace the Controller Antilock Brake in accordance with the service information. Perform NAG1 TRANSMISSION VERIFICATION TEST - VER 1.	All
6	Turn the ignition off. Disconnect the Shifter Assembly harness connector. Disconnect the DRBIII® from the DLC. Measure the resistance of the K-ABS, Shifter Assembly circuit between the Shifter Assembly connector and the DLC. Is the resistance below 5.0 ohms? Yes → Replace the Shifter Assembly in accordance with the Service Information. Perform NAG1 TRANSMISSION VERIFICATION TEST - VER 1. No → Repair the K-ABS, Shifter Assembly circuit for an open. Perform NAG1 TRANSMISSION VERIFICATION TEST - VER 1.	All

Symptom:

***NO RESPONSE FROM TRANSMISSION CONTROL MODULE**

POSSIBLE CAUSES
CHECK POWERS AND GROUNDS TO THE TRANSMISSION CONTROL MODULE K-TCM CIRCUIT SHORTED TO GROUND K-TCM CIRCUIT SHORTED TO VOLTAGE K-TCM CIRCUIT OPEN TRANSMISSION CONTROL MODULE

TEST	ACTION	APPLICABILITY
1	Turn the ignition off. Disconnect the Transmission Control Module harness connectors. Check each power and ground circuit to the module. Were any problems found? Yes → Refer to the wiring diagrams located in the service information to help isolate an open or shorted condition. Repair as necessary. Perform NAG1 TRANSMISSION VERIFICATION TEST - VER 1. No → Go To 2	All
2	Turn the ignition off. Disconnect the TCM harness connectors. Disconnect the DRBIII® from the DLC. Measure the resistance between ground and the K-TCM circuit. Is the resistance below 5.0 ohms? Yes → Repair the K-TCM circuit for a short to ground. Perform NAG1 TRANSMISSION VERIFICATION TEST - VER 1. No → Go To 3	All
3	Turn the ignition off. Disconnect the DRBIII® from the DLC. Disconnect the TCM harness connectors. Turn the ignition on. Using a 12-volt test light connected to ground, probe the K-TCM circuit. NOTE: The test light must illuminate brightly. Compare the brightness to that of a direct connection to the battery. Does the test light illuminate brightly? Yes → Repair the K-TCM circuit for a short to voltage. Perform NAG1 TRANSMISSION VERIFICATION TEST - VER 1. No → Go To 4	All

***NO RESPONSE FROM TRANSMISSION CONTROL MODULE — Continued**

TEST	ACTION	APPLICABILITY
4	<p>Turn the ignition off. Disconnect the TCM harness connectors. Disconnect the DRBIII® from the DLC. Measure the resistance of the K-TCM circuit between the TCM connector and the DLC. Is the resistance below 5.0 ohms?</p> <p>Yes → Replace the Transmission Control Module in accordance with the Service Information. Perform NAG1 TRANSMISSION VERIFICATION TEST - VER 1.</p> <p>No → Repair the K-TCM circuit for an open. Perform NAG1 TRANSMISSION VERIFICATION TEST - VER 1.</p>	All

Symptom:

A/C COMPRESSOR CONTROL HIGH OR OPEN (ACTIVE)

POSSIBLE CAUSES
A/C COMPRESSOR CLUTCH CONTROL CIRCUIT SHORTED TO VOLTAGE
A/C COMPRESSOR CLUTCH
A/C COMPRESSOR CLUTCH CONTROL CIRCUIT OPEN
AUTOMATIC TEMPERATURE CONTROL (ATC)

TEST	ACTION	APPLICABILITY
1	Turn the ignition off. NOTE: Check connectors - Clean/repair as necessary. Disconnect the A/C Compressor Clutch harness connector. Turn the ignition on. Press the Air Conditioning switch off. Measure the voltage of the A/C Compressor Clutch Control circuit. Is the voltage above 10.0 volts? Yes → Go To 2 No → Go To 4	All
2	Turn the ignition off. NOTE: Check connectors - Clean/repair as necessary. Disconnect the Automatic Temperature Control (ATC) C1 harness connector. Disconnect the A/C Compressor Clutch harness connector. Turn the ignition on. Measure the voltage of the A/C Compressor Clutch Control circuit. Is the voltage above 0.2 volts? Yes → Repair the A/C Compressor Clutch Control circuit for a short to voltage. Perform BODY VERIFICATION TEST - VER 1. No → Go To 3	All
3	Turn the ignition off. NOTE: Check connectors - Clean/repair as necessary. Reconnect the Automatic Temperature Control (ATC) C1 harness connector. Reconnect the A/C Compressor Clutch harness connector. Verify that the A/C Compressor Clutch Ground is clean and tight. Turn the ignition on. With the DRBIII®, erase DTCs. Turn the ignition off, wait 5 seconds, then turn the ignition on. With the DRBIII®, read Automatic Temperature Control DTCs. Does the DRBIII® display: A/C COMPRESSOR CONTROL HIGH OR OPEN? Yes → Replace the A/C Compressor Clutch in accordance with the Service Information. Perform BODY VERIFICATION TEST - VER 1. No → Test Complete.	All

A/C COMPRESSOR CONTROL HIGH OR OPEN (ACTIVE) — Continued

TEST	ACTION	APPLICABILITY
4	<p>Turn the ignition off.</p> <p>NOTE: Check connectors - Clean/repair as necessary.</p> <p>Disconnect the Automatic Temperature Control (ATC) C1 harness connector.</p> <p>Disconnect the A/C Compressor Clutch harness connector.</p> <p>Measure the resistance of the A/C Compressor Clutch Control circuit between the Automatic Temperature Control (ATC) C1 harness connector and the A/C Compressor Clutch harness connector.</p> <p>Is the resistance below 5.0 ohms?</p> <p>Yes → Replace the Automatic Temperature Control (ATC) in accordance with the Service Information. Perform BODY VERIFICATION TEST - VER 1.</p> <p>No → Repair the A/C Compressor Clutch Control circuit for an open. Perform BODY VERIFICATION TEST - VER 1.</p>	All

Symptom List:

A/C COMPRESSOR CONTROL HIGH OR OPEN (STORED)
A/C COMPRESSOR CONTROL SHORTED LOW (STORED)
AIR OUTLET TEMP SENSOR HIGH OR OPEN (STORED)
AIR OUTLET TEMP SENSOR SHORTED LOW (STORED)
AUX FAN RELAY CONTROL HIGH OR OPEN (STORED)
AUX FAN RELAY CONTROL SHORTED LOW (STORED)
BLOWER STAGE 1 HIGH OR OPEN (STORED)
BLOWER STAGE 1 SHORTED LOW (STORED)
CABIN HEATER CONTROL HIGH OR OPEN (STORED)
CABIN HEATER CONTROL SHORTED LOW (STORED)
CIRC PUMP CONTROL HIGH OR OPEN (STORED)
CIRC PUMP CONTROL SHORTED LOW (STORED)
EVAP TEMP SENSOR HIGH OR OPEN (STORED)
EVAP TEMP SENSOR SHORTED LOW (STORED)
NO COMMUNICATION BUS (STORED)
NO COMMUNICATION WITH ECM (STORED)
NO COMMUNICATION WITH IC (STORED)
RECIRC AIR SOLENOID CONTROL HIGH OR OPEN (STORED)
RECIRC AIR SOLENOID CONTROL SHORTED LOW (STORED)
REFRIG PRESS SENSOR HIGH OR OPEN (STORED)
REFRIG PRESS SENSOR SHORTED LOW (STORED)
WATER CYCLE VALVE CONTROL HIGH OR OPEN (STORED)
WATER CYCLE VALVE CONTROL SHORTED LOW (STORED)

Test Note: All symptoms listed above are diagnosed using the same tests. The title for the tests will be A/C COMPRESSOR CONTROL HIGH OR OPEN (STORED).

When Monitored and Set Condition:

NO COMMUNICATION BUS (STORED)

When Monitored: With the ignition on.

Set Condition: This DTC will set if the Automatic Temperature Control (ATC) fails to receive all module messages.

NO COMMUNICATION WITH ECM (STORED)

When Monitored: With the ignition on.

Set Condition: This DTC will set if the Automatic Temperature Control (ATC) fails to receive all messages from the ECM.

A/C COMPRESSOR CONTROL HIGH OR OPEN (STORED) — Continued**NO COMMUNICATION WITH IC (STORED)**

When Monitored: With the ignition on.

Set Condition: This DTC will set if the Automatic Temperature Control (ATC) fails to receive all messages from the Instrument Cluster.

POSSIBLE CAUSES

CHECK FOR ACTIVE AUTOMATIC TEMPERATURE CONTROL (ATC) DTCS
INTERMITTENT CONDITION

TEST	ACTION	APPLICABILITY
1	<p>NOTE: All of the following criteria must be met in order to successfully run the ATC Function Test. Place the shift lever in Park. Turn the ignition on. With the DRBIII®, record and erase ATC DTC's. Start the engine. Allow the engine to reach normal operating temperature. Set the blower to high speed. Press the Air Conditioning switch On. With the DRBIII®, verify that the ambient temperature is above 59°F (15°C), the refrigerant pressure is between 29 and 348 PSI (2 and 24 bar), the evaporator temperature is above 36.5°F (2.5°C), and the coolant temperature is above 158°F (70°C). With the DRBIII® in Automatic Temperature Control (ATC), select System Tests and select ATC Function Test. When the ATC Function Test is complete, proceed as follows: With the DRBIII®, read the active ATC DTCs. Does the DRBIII® display any DTCs?</p> <p>Yes → Return to the Heating & A/C Symptom List and choose the symptom(s). Perform BODY VERIFICATION TEST - VER 1.</p> <p>No → Using the wiring diagram/schematic as a guide, inspect the wiring and connectors related to the circuit(s) that caused the original DTC(s) to set. Perform BODY VERIFICATION TEST - VER 1.</p>	All

Symptom:

A/C COMPRESSOR CONTROL SHORTED LOW (ACTIVE)

POSSIBLE CAUSES

A/C COMPRESSOR CLUTCH

A/C COMPRESSOR CLUTCH CONTROL CIRCUIT SHORTED TO GROUND

A/C COMPRESSOR CLUTCH CONTROL CIRCUIT SHORTED TO GROUND CIRCUIT

A/C COMPRESSOR CLUTCH CONTROL CIRCUIT SHORTED TO SENSOR GROUND CIRCUIT

AUTOMATIC TEMPERATURE CONTROL (ATC)

TEST	ACTION	APPLICABILITY
1	<p>Turn the ignition on. Press the Air Conditioning switch off. Turn the ignition off. Disconnect the A/C Compressor Clutch harness connector. Turn the ignition on. With the DRBIII®, record and erase Automatic Temperature Control DTCs. Turn the ignition off, wait 5 seconds, then turn the ignition on. With the DRBIII®, read the Automatic Temperature Control DTCs. Does the DRBIII® display: A/C COMPRESSOR CONTROL HIGH OR OPEN?</p> <p>Yes → Replace the A/C Compressor Clutch in accordance with the Service Information. Perform BODY VERIFICATION TEST - VER 1.</p> <p>No → Go To 2</p>	All
2	<p>Turn the ignition off. Disconnect the A/C Compressor Clutch harness connector. Disconnect the Automatic Temperature Control (ATC) C1 harness connector. Measure the resistance between ground and the A/C Compressor Clutch Control circuit. Is the resistance below 10k ohms?</p> <p>Yes → Repair the A/C Compressor Clutch Control circuit for a short to ground. Perform BODY VERIFICATION TEST - VER 1.</p> <p>No → Go To 3</p>	All
3	<p>Turn the ignition off. Disconnect the A/C Compressor Clutch harness connector. Disconnect the Automatic Temperature Control (ATC) C1 harness connector. Measure the resistance between the A/C Compressor Clutch Control circuit and the Ground circuit in the Automatic Temperature Control C1 harness connector. Is the resistance below 10k ohms?</p> <p>Yes → Repair the A/C Compressor Clutch Control circuit for a short to the Ground circuit. Perform BODY VERIFICATION TEST - VER 1.</p> <p>No → Go To 4</p>	All

A/C COMPRESSOR CONTROL SHORTED LOW (ACTIVE) — Continued

TEST	ACTION	APPLICABILITY
4	<p>Turn the ignition off. Disconnect the A/C Compressor Clutch harness connector. Disconnect the Automatic Temperature Control (ATC) C1 harness connector. Measure the resistance between the A/C Compressor Clutch Control circuit and the Sensor Ground circuit in the Automatic Temperature Control C1 harness connector. Is the resistance below 10k ohms?</p> <p>Yes → Repair the A/C Compressor Clutch Control circuit for a short to the Sensor Ground circuit. Perform BODY VERIFICATION TEST - VER 1.</p> <p>No → Replace the Automatic Temperature Control (ATC) in accordance with the Service Information. Perform BODY VERIFICATION TEST - VER 1.</p>	All

Symptom:

AIR OUTLET TEMP SENSOR HIGH OR OPEN (ACTIVE)

POSSIBLE CAUSES
AIR OUTLET TEMPERATURE SENSOR SIGNAL CIRCUIT SHORTED TO VOLTAGE
AUTOMATIC TEMPERATURE CONTROL (ATC)
AUTOMATIC TEMPERATURE CONTROL (ATC)
AIR OUTLET TEMPERATURE SENSOR SIGNAL CIRCUIT OPEN
SENSOR GROUND CIRCUIT OPEN
AIR OUTLET TEMPERATURE SENSOR

TEST	ACTION	APPLICABILITY
1	Turn the ignition off. NOTE: Check connectors - Clean/repair as necessary. Disconnect the Air Outlet Temperature Sensor harness connector. Turn the ignition on. While back probing, measure the voltage between the Air Outlet Temperature Sensor Signal circuit and the Sensor Ground circuit. Is the voltage above 5.3 volts? Yes → Go To 2 No → Go To 3	All
2	Turn the ignition off. NOTE: Check connectors - Clean/repair as necessary. Disconnect the Air Outlet Temperature Sensor harness connector. Disconnect the Automatic Temperature Control (ATC) C1 harness connector. Turn the ignition on. Measure the voltage of the Air Outlet Temperature Sensor Signal circuit. Is the voltage above 0.2 volts? Yes → Repair the Air Outlet Temperature Sensor Signal circuit for a short to voltage. Perform BODY VERIFICATION TEST - VER 1. No → Replace the Automatic Temperature Control (ATC) in accordance with the Service Information. Perform BODY VERIFICATION TEST - VER 1.	All
3	Turn the ignition off. NOTE: Check connectors - Clean/repair as necessary. Disconnect the Air Outlet Temperature Sensor harness connector. Turn the ignition on. While back probing, measure the voltage between the Air Outlet Temperature Sensor Signal circuit and Sensor Ground circuit in the Automatic Temperature Control (ATC) C1 harness connector. Is the voltage above 4.5 volts? Yes → Go To 4 No → Replace the Automatic Temperature Control (ATC) in accordance with the Service Information. Perform BODY VERIFICATION TEST - VER 1.	All

AIR OUTLET TEMP SENSOR HIGH OR OPEN (ACTIVE) — Continued

TEST	ACTION	APPLICABILITY
4	Turn the ignition off. NOTE: Check connectors - Clean/repair as necessary. Disconnect the Automatic Temperature Control (ATC) C1 harness connector. Disconnect the Air Outlet Temperature Sensor harness connector. Measure the resistance of the Air Outlet Temperature Sensor Signal circuit between the Automatic Temperature Control (ATC) C1 harness connector and the Air Outlet Temperature Sensor harness connector. Is the resistance below 5.0 ohms? Yes → Go To 5 No → Repair the Air Outlet Temperature Sensor Signal circuit for an open. Perform BODY VERIFICATION TEST - VER 1.	All
5	Turn the ignition off. NOTE: Check connectors - Clean/repair as necessary. Disconnect the Automatic Temperature Control (ATC) C1 harness connector. Disconnect the Air Outlet Temperature Sensor harness connector. Measure the resistance of the Sensor Ground circuit between the Automatic Temperature Control (ATC) C1 harness connector and the Air Outlet Temperature Sensor harness connector. Is the resistance below 5.0 ohms? Yes → Replace the Air Outlet Temperature Sensor in accordance with the Service Information. Perform BODY VERIFICATION TEST - VER 1. No → Repair the Sensor Ground circuit for an open. Perform BODY VERIFICATION TEST - VER 1.	All

Symptom:

AIR OUTLET TEMP SENSOR SHORTED LOW (ACTIVE)

POSSIBLE CAUSES

AIR OUTLET TEMPERATURE SENSOR
 AIR OUTLET TEMPERATURE SENSOR SIGNAL CIRCUIT SHORTED TO GROUND
 AIR OUTLET TEMPERATURE SENSOR SIGNAL CIRCUIT SHORTED TO GROUND CIRCUIT
 AUTOMATIC TEMPERATURE CONTROL (ATC)
 AIR OUTLET TEMPERATURE SENSOR SIGNAL CIRCUIT SHORT TO SENSOR GROUND CIRCUIT

TEST	ACTION	APPLICABILITY
1	Turn the ignition off. Disconnect the Air Outlet Temperature Sensor harness connector. Turn the ignition on. With the DRBIII®, record and erase Automatic Temperature Control DTCs. Turn the ignition off, wait 5 seconds, then turn the ignition on. With the DRBIII®, read the Automatic Temperature Control DTCs. Does the DRBIII® display: AIR OUTLET TEMP SENSOR HIGH OR OPEN? Yes → Replace the Air Outlet Temperature Sensor in accordance with the Service Information. Perform BODY VERIFICATION TEST - VER 1. No → Go To 2	All
2	Turn the ignition off. Disconnect the Automatic Temperature Control (ATC) C1 harness connector. Measure the resistance between ground and the Air Outlet Temperature Sensor Signal circuit. Is the resistance below 10k ohms? Yes → Repair the Air Outlet Temperature Sensor Signal circuit for a short to ground. Perform BODY VERIFICATION TEST - VER 1. No → Go To 3	All
3	Turn the ignition off. Disconnect the Automatic Temperature Control (ATC) C1 harness connector. Measure the resistance between the Air Outlet Temperature Sensor Signal circuit and the Ground circuit. Is the resistance below 10k ohms? Yes → Repair the Air Outlet Temperature Sensor Signal circuit for a short to the Ground circuit. Perform BODY VERIFICATION TEST - VER 1. No → Go To 4	All

AIR OUTLET TEMP SENSOR SHORTED LOW (ACTIVE) — Continued

TEST	ACTION	APPLICABILITY
4	<p>Turn the ignition off. Disconnect the Air Outlet Temperature Sensor harness connector. Disconnect the Automatic Temperature Control (ATC) C1 harness connector. Measure the resistance between the Air Outlet Temperature Sensor Signal circuit and the Sensor Ground circuit. Is the resistance below 10k ohms?</p> <p>Yes → Repair the Air Outlet Temperature Sensor Signal circuit for a short to the Sensor Ground circuit. Perform BODY VERIFICATION TEST - VER 1.</p> <p>No → Replace the Automatic Temperature Control (ATC) in accordance with the Service Information. Perform BODY VERIFICATION TEST - VER 1.</p>	All

Symptom List:

ATC FUNCTION TEST COOL FAILURE
ATC FUNCTION TEST FAILURE
ATC FUNCTION TEST HEAT FAILURE

Test Note: All symptoms listed above are diagnosed using the same tests. The title for the tests will be ATC FUNCTION TEST COOL FAILURE.

When Monitored and Set Condition:

ATC FUNCTION TEST COOL FAILURE

When Monitored: With the engine running.

Set Condition: This DTC will set if specific operating criteria are not met when attempting to run the ATC Function Test.

ATC FUNCTION TEST FAILURE

When Monitored: With the engine running.

Set Condition: This DTC will set if specific operating criteria are not met when attempting to run the ATC Function Test.

ATC FUNCTION TEST HEAT FAILURE

When Monitored: With the engine running.

Set Condition: This DTC will set if specific operating criteria are not met when attempting to run the ATC Function Test.

POSSIBLE CAUSES

ATC FUNCTION TEST OPERATING CRITERIA NOT MET
AUTOMATIC TEMPERATURE CONTROL (ATC) DTC(S) PRESENT
ENGINE CONTROL MODULE DTC(S) PRESENT
CRITERIA TO RUN ATC FUNCTION TEST NOT MET AND NO DTCS PRESENT

ATC FUNCTION TEST COOL FAILURE — Continued

TEST	ACTION	APPLICABILITY
1	<p>Verify that all of the following criteria was met when attempting to run the ATC Function Test.</p> <p>The vehicle was stationary.</p> <p>The engine was running.</p> <p>The air conditioning switch was On.</p> <p>The ambient temperature was above 59°F (15°C).</p> <p>The refrigerant pressure was between 29 and 348 PSI (2 and 24 bar).</p> <p>The evaporator temperature was above 36.5°F (2.5°C).</p> <p>The coolant temperature was above 158°F (70°C).</p> <p>Was all criteria met when attempting to run the ATC Function Test?</p> <p>Yes → Go To 2</p> <p>No → Attempt to activate the ATC Function Test when all of the specific operating criteria are met. If the criteria cannot be met, proceed to Test 2 of this procedure.</p> <p>Perform BODY VERIFICATION TEST - VER 1.</p>	All
2	<p>Turn the ignition on.</p> <p>With the DRBIII®, read Automatic Temperature Control DTCs.</p> <p>Does the DRBIII® display any DTCs?</p> <p>Yes → Return to the Heating & A/C symptom list and choose the symptom(s).</p> <p>Perform BODY VERIFICATION TEST - VER 1.</p> <p>No → Go To 3</p>	All
3	<p>Turn the ignition on.</p> <p>With the DRBIII®, read Engine Control Module DTCs.</p> <p>Does the DRBIII® display any DTCs?</p> <p>Yes → Refer to Powertrain Diagnostic information for the related symptom(s).</p> <p>Perform BODY VERIFICATION TEST - VER 1.</p> <p>No → Refer to Service Information to diagnose the system(s) that failed to meet the ATC Function Test operating criteria.</p> <p>Perform BODY VERIFICATION TEST - VER 1.</p>	All

Symptom:

AUX FAN RELAY CONTROL HIGH OR OPEN (ACTIVE)

POSSIBLE CAUSES
A/C AUXILIARY FAN RELAY HIGH SIDE CONTROL CIRCUIT SHORTED TO VOLTAGE GROUND CIRCUIT OPEN A/C AUXILIARY FAN RELAY HIGH SIDE CONTROL CIRCUIT OPEN A/C AUXILIARY FAN RELAY AUTOMATIC TEMPERATURE CONTROL (ATC)

TEST	ACTION	APPLICABILITY
1	Turn the ignition off. NOTE: Check connectors - Clean/repair as necessary. Remove the A/C Auxiliary Fan Relay from the relay center. Disconnect the Automatic Temperature Control (ATC) C1 harness connector. Measure the voltage of the A/C Auxiliary Fan Relay High Side Control circuit. Is the voltage above 0.2 volts? Yes → Repair the A/C Auxiliary Fan Relay High Side Control circuit for a short to voltage. Perform BODY VERIFICATION TEST - VER 1. No → Go To 2	All
2	Turn the ignition off. NOTE: Check connectors - Clean/repair as necessary. Remove the A/C Auxiliary Fan Relay from the relay center. Measure the resistance between ground and the Ground circuit in the relay center (A/C Auxiliary Fan Relay connector terminal 85). Is the resistance below 5.0 ohms? Yes → Go To 3 No → Repair the Ground circuit for an open. Perform BODY VERIFICATION TEST - VER 1.	All
3	Turn the ignition off. NOTE: Check connectors - Clean/repair as necessary. Remove the A/C Auxiliary Fan Relay from the relay center. Disconnect the Automatic Temperature Control (ATC) C1 harness connector. Measure the resistance of the A/C Auxiliary Fan Relay High Side Control circuit between the Automatic Temperature Control (ATC) C1 harness connector and the relay center (A/C Auxiliary Fan Relay connector terminal 86). Is the resistance below 5.0 ohms? Yes → Go To 4 No → Repair the A/C Auxiliary Fan Relay High Side Control circuit for an open. Perform BODY VERIFICATION TEST - VER 1.	All

AUX FAN RELAY CONTROL HIGH OR OPEN (ACTIVE) — Continued

TEST	ACTION	APPLICABILITY
4	<p>Turn the ignition off.</p> <p>NOTE: Check connectors - Clean/repair as necessary.</p> <p>Reconnect the Automatic Temperature Control (ATC) C1 harness connector.</p> <p>Install a substitute relay in place of the A/C Auxiliary Fan Relay.</p> <p>Turn the ignition on.</p> <p>With the DRBIII®, erase Automatic Temperature Control DTCs.</p> <p>Turn the ignition off, wait 5 seconds, then turn the ignition on.</p> <p>With the DRBIII®, read Automatic Temperature Control DTCs.</p> <p>Does the DRBIII® display: AUX FAN RELAY CONTROL HIGH OR OPEN?</p> <p>Yes → Replace the Automatic Temperature Control (ATC) in accordance with the Service Information. Reinstall the original A/C Auxiliary Fan Relay.</p> <p>Perform BODY VERIFICATION TEST - VER 1.</p> <p>No → Replace the original A/C Auxiliary Fan Relay in accordance with the Service Information.</p> <p>Perform BODY VERIFICATION TEST - VER 1.</p>	All

Symptom:

AUX FAN RELAY CONTROL SHORTED LOW (ACTIVE)

POSSIBLE CAUSES

A/C AUXILIARY FAN RELAY

A/C AUXILIARY FAN RELAY HIGH SIDE CONTROL CIRCUIT SHORTED TO GROUND

A/C AUXILIARY FAN RELAY HIGH SIDE CONTROL CIRCUIT SHORTED TO GROUND CIRCUIT

AUTOMATIC TEMPERATURE CONTROL (ATC)

A/C AUXILIARY FAN RELAY HIGH SIDE CONTROL CKT SHORTED TO SENSOR GROUND CKT

TEST	ACTION	APPLICABILITY
1	<p>Turn the ignition off. Install a substitute relay in place of the A/C Auxiliary Fan Relay. NOTE: All of the following criteria must be met in order to successfully run the ATC Function Test. Place the shift lever in Park. Turn the ignition on. With the DRBIII®, record and erase ATC DTC's. Start the engine. Allow the engine to reach normal operating temperature. Set the blower to high speed. Press the Air Conditioning switch On. With the DRBIII®, verify that the ambient temperature is above 59°F (15°C), the refrigerant pressure is between 29 and 348 PSI (2 and 24 bar), the evaporator temperature is above 36.5°F (2.5°C), and the coolant temperature is above 158°F (70°C). With the DRBIII® in Automatic Temperature Control (ATC), select System Tests and select ATC Function Test. When the ATC Function Test is complete, proceed as follows: With the DRBIII®, read the active ATC DTCs. Does the DRBIII® display: AUX FAN RELAY CONTROL SHORTED LOW?</p> <p style="padding-left: 40px;">Yes → Go To 2</p> <p style="padding-left: 40px;">No → Replace the original A/C Auxiliary Fan Relay in accordance with the Service Information. Perform BODY VERIFICATION TEST - VER 1.</p>	All
2	<p>Turn the ignition off. Remove the substitute A/C Auxiliary Fan Relay from the relay center. Disconnect the Automatic Temperature Control (ATC) C1 harness connector. Measure the resistance between ground and the A/C Auxiliary Fan Relay High Side Control circuit. Is the resistance below 10K ohms?</p> <p style="padding-left: 40px;">Yes → Repair the A/C Auxiliary Fan Relay High Side Control circuit for a short to ground. Reinstall the original A/C Auxiliary Fan Relay. Perform BODY VERIFICATION TEST - VER 1.</p> <p style="padding-left: 40px;">No → Go To 3</p>	All

AUX FAN RELAY CONTROL SHORTED LOW (ACTIVE) — Continued

TEST	ACTION	APPLICABILITY
3	<p>Turn the ignition off. Remove the A/C Auxiliary Fan Relay from the relay center. Disconnect the Automatic Temperature Control (ATC) C1 harness connector. Measure the resistance between the A/C Auxiliary Fan Relay High Side Control circuit and the Ground circuit in the Automatic Temperature Control (ATC) C1 harness connector. Is the resistance below 10K ohms?</p> <p>Yes → Repair the A/C Auxiliary Fan Relay High Side Control circuit for a short to the Ground circuit. Perform BODY VERIFICATION TEST - VER 1.</p> <p>No → Go To 4</p>	All
4	<p>Turn the ignition off. Remove the A/C Auxiliary Fan Relay from the relay center. Disconnect the Automatic Temperature Control (ATC) C1 harness connector. Measure the resistance between the A/C Auxiliary Fan Relay High Side Control circuit and the Sensor Ground circuit in the Automatic Temperature Control (ATC) C1 harness connector. Is the resistance below 10K ohms?</p> <p>Yes → Repair the A/C Auxiliary Fan Relay High Side Control circuit for a short to the Sensor Ground circuit. Perform BODY VERIFICATION TEST - VER 1.</p> <p>No → Replace the Automatic Temperature Control (ATC) in accordance with the Service Information. Perform BODY VERIFICATION TEST - VER 1.</p>	All

Symptom:

BLOWER STAGE 1 HIGH OR OPEN (ACTIVE)

POSSIBLE CAUSES
<p>BLOWER MOTOR</p> <p>BLOWER MOTOR DRIVER CIRCUIT(S) SHORTED TO VOLTAGE</p> <p>BLOWER MOTOR DRIVER CIRCUIT(S) OPEN</p> <p>BLOWER MOTOR RESISTOR BLOCK</p> <p>AUTOMATIC TEMPERATURE CONTROL (ATC)</p>

TEST	ACTION	APPLICABILITY
1	<p>Turn the ignition off.</p> <p>NOTE: Check connectors - Clean/repair as necessary.</p> <p>Disconnect the Blower Motor harness connector.</p> <p>Connect a fused jumper wire between Battery (+) and Blower Motor cavity 1.</p> <p>Connect a jumper wire between ground and Blower Motor cavity 2.</p> <p>Does the Blower Motor run at full speed?</p> <p style="padding-left: 40px;">Yes → Go To 2</p> <p style="padding-left: 40px;">No → Replace the Blower Motor in accordance with the Service Information.</p> <p style="padding-left: 40px;">Perform BODY VERIFICATION TEST - VER 1.</p>	All
2	<p>Turn the ignition off.</p> <p>NOTE: Check connectors - Clean/repair as necessary.</p> <p>Disconnect the Blower Motor Resistor Block harness connector.</p> <p>Disconnect the Blower Motor harness connector.</p> <p>Disconnect the Automatic Temperature Control (ATC) C2 harness connector.</p> <p>Turn the ignition on.</p> <p>Measure the voltage of each of the Blower Motor Driver circuits (Low, M1, M2, High).</p> <p>Is the voltage above 0.2 volts on any of the circuits?</p> <p style="padding-left: 40px;">Yes → Repair each circuit with voltage above 0.2 volts for a short to voltage.</p> <p style="padding-left: 40px;">Perform BODY VERIFICATION TEST - VER 1.</p> <p style="padding-left: 40px;">No → Go To 3</p>	All
3	<p>Turn the ignition off.</p> <p>NOTE: Check connectors - Clean/repair as necessary.</p> <p>Disconnect the Automatic Temperature Control (ATC) C2 harness connector.</p> <p>Disconnect the Blower Motor Resistor Block harness connector.</p> <p>Disconnect the Blower Motor harness connector.</p> <p>Measure the resistance of the Blower Motor Driver circuits (Low, M1, M2, High) between the Automatic Temperature Control (ATC) C2 harness connector and the Blower Motor Resistor Block harness connector.</p> <p>Measure the resistance of the Blower Motor High Driver circuit between the Automatic Temperature Control (ATC) C2 harness connector and the Blower Motor harness connector.</p> <p>Is the resistance below 5.0 ohms on each of the circuits?</p> <p style="padding-left: 40px;">Yes → Go To 4</p> <p style="padding-left: 40px;">No → Repair each circuit with a resistance above 5.0 ohms for an open.</p> <p style="padding-left: 40px;">Perform BODY VERIFICATION TEST - VER 1.</p>	All

BLOWER STAGE 1 HIGH OR OPEN (ACTIVE) — Continued

TEST	ACTION	APPLICABILITY
4	<p>Turn the ignition off.</p> <p>NOTE: Check connectors - Clean/repair as necessary.</p> <p>Disconnect the Blower Motor Resistor Block harness connector.</p> <p>Measure the resistance between Blower Motor Resistor Block cavity 2 and cavity 1. The approximate resistance should be 1.4 ohms.</p> <p>Measure the resistance between Blower Motor Resistor Block cavity 2 and cavity 3. The approximate resistance should be 0.8 ohms.</p> <p>Measure the resistance between Blower Motor Resistor Block cavity 2 and cavity 4. The approximate resistance should be 1.6 ohms.</p> <p>Is the resistance as specified for each circuit?</p> <p>Yes → Replace the Automatic Temperature Control (ATC) in accordance with the Service Information. Perform BODY VERIFICATION TEST - VER 1.</p> <p>No → Replace the Blower Motor Resistor Block in accordance with the Service Information. Perform BODY VERIFICATION TEST - VER 1.</p>	All

Symptom:

BLOWER STAGE 1 SHORTED LOW (ACTIVE)

POSSIBLE CAUSES

BLOWER MOTOR FUSE
 BLOWER MOTOR
 BLOWER MOTOR DRIVER CIRCUIT(S) SHORTED TO GROUND
 FUSED B+ CIRCUIT SHORTED TO GROUND
 BLOWER MOTOR RESISTOR BLOCK
 AUTOMATIC TEMPERATURE CONTROL (ATC)

TEST	ACTION	APPLICABILITY
1	Turn the ignition off. Remove and inspect the Blower Motor Fuse, and replace it if necessary. NOTE: All of the following criteria must be met in order to successfully run the ATC Function Test. Place the shift lever in Park. Turn the ignition on. With the DRBIII®, record and erase ATC DTC's. Start the engine. Allow the engine to reach normal operating temperature. Set the blower to high speed. Press the Air Conditioning switch On. With the DRBIII®, verify that the ambient temperature is above 59°F (15°C), the refrigerant pressure is between 29 and 348 PSI (2 and 24 bar), the evaporator temperature is above 36.5°F (2.5°C), and the coolant temperature is above 158°F (70°C). With the DRBIII® in Automatic Temperature Control (ATC), select System Tests and select ATC Function Test. When the ATC Function Test is complete, proceed as follows: With the DRBIII®, read the active ATC DTCs. Does the DRBIII® display: BLOWER STAGE ONE SHORTED LOW? Yes → Go To 2 No → Refer to the wiring diagrams located in the service information to help isolate a possible intermittent short to ground condition. Perform BODY VERIFICATION TEST - VER 1.	All
2	Turn the ignition off. Disconnect the Blower Motor harness connector. Connect a fused jumper wire between Battery (+) and Blower Motor cavity 1. Connect a jumper wire between ground and Blower Motor cavity 2. Does the Blower Motor run at full speed? Yes → Go To 3 No → Replace the Blower Motor in accordance with the Service Information. Remove and inspect the Blower Motor Fuse, and replace it if necessary. Perform BODY VERIFICATION TEST - VER 1.	All

BLOWER STAGE 1 SHORTED LOW (ACTIVE) — Continued

TEST	ACTION	APPLICABILITY
3	<p>Turn the ignition off. Disconnect the Blower Motor Resistor harness connector. Disconnect the Blower Motor harness connector. Disconnect the Automatic Temperature Control (ATC) C2 harness connector. Measure the resistance between ground and each of the Blower Motor Driver circuits (Low, M1, M2, High). Is the resistance below 10k ohms on any of the circuits?</p> <p>Yes → Repair each circuit with a resistance below 10k ohms for a short to ground. Remove and inspect the Blower Motor Fuse, and replace it if necessary. Perform BODY VERIFICATION TEST - VER 1.</p> <p>No → Go To 4</p>	All
4	<p>Turn the ignition off. Remove the Blower Motor Fuse. Disconnect the Automatic Temperature Control (ATC) C2 harness connector. Measure the resistance between ground and the Fused B+ circuit. Is the resistance below 10k ohms?</p> <p>Yes → Repair the Fused B+ circuit for a short to Ground. Remove and inspect the Blower Motor Fuse, and replace it if necessary. Perform BODY VERIFICATION TEST - VER 1.</p> <p>No → Go To 5</p>	All
5	<p>Turn the ignition off. Disconnect the Blower Motor Resistor Block harness connector. Measure the resistance between Blower Motor Resistor Block cavity 2 and cavity 1. The approximate resistance should be 1.4 ohms. Measure the resistance between Blower Motor Resistor Block cavity 2 and cavity 3. The approximate resistance should be 0.8 ohms. Measure the resistance between Blower Motor Resistor Block cavity 2 and cavity 4. The approximate resistance should be 1.6 ohms. Is the resistance as specified for each circuit?</p> <p>Yes → Replace the Automatic Temperature Control (ATC) in accordance with the Service Information. Remove and inspect the Blower Motor Fuse, and replace it if necessary. Perform BODY VERIFICATION TEST - VER 1.</p> <p>No → Replace the Blower Motor Resistor Block in accordance with the Service Information. Remove and inspect the Blower Motor Fuse, and replace it if necessary. Perform BODY VERIFICATION TEST - VER 1.</p>	All

Symptom:

CABIN HEATER CONTROL HIGH OR OPEN (ACTIVE)

POSSIBLE CAUSES
CABIN HEATER OR HEATER BOOSTER CONTROL UNIT
CABIN HEATER CONTROL CIRCUIT SHORTED TO VOLTAGE
AUTOMATIC TEMPERATURE CONTROL (ATC)
CABIN HEATER CONTROL CIRCUIT OPEN
AUTOMATIC TEMPERATURE CONTROL (ATC)

TEST	ACTION	APPLICABILITY
1	<p>Turn the ignition on. Verify that the Cabin Heater or Heater Booster is switched off. Turn the ignition off. NOTE: Check connectors - Clean/repair as necessary. Disconnect the Cabin Heater or Heater Booster harness connector. Connect a 12-volt test light between the Cabin Heater Control circuit and ground. Turn the ignition on. The test light should operate as follows: With the Cabin Heater or Heater Booster switched off, the test light should not illuminate. Press the Cabin Heater or Heater Booster switch on. The test light should illuminate brightly. Does the test light function as specified?</p> <p style="padding-left: 40px;">Yes, Light Only Illuminates w/Switch On Replace the Cabin Heater Assembly or the Heater Booster Assembly in accordance with the Service Information. Perform BODY VERIFICATION TEST - VER 1.</p> <p style="padding-left: 40px;">No, Light Illuminates w/Switch Off Go To 2</p> <p style="padding-left: 40px;">No, Light Will Not Illuminate Go To 3</p>	All
2	<p>Turn the ignition off. NOTE: Check connectors - Clean/repair as necessary. Disconnect the Cabin Heater or Heater Booster harness connector. Disconnect the Automatic Temperature Control (ATC) C1 harness connector. Turn the ignition on. Measure the voltage of the Cabin Heater Control circuit. Is the voltage above 0.2 volts?</p> <p style="padding-left: 40px;">Yes → Repair the Cabin Heater Control circuit for a short to voltage. Perform BODY VERIFICATION TEST - VER 1.</p> <p style="padding-left: 40px;">No → Replace the Automatic Temperature Control (ATC) in accordance with the Service Information. Perform BODY VERIFICATION TEST - VER 1.</p>	All

CABIN HEATER CONTROL HIGH OR OPEN (ACTIVE) — Continued

TEST	ACTION	APPLICABILITY
3	<p>Turn the ignition off.</p> <p>NOTE: Check connectors - Clean/repair as necessary.</p> <p>Disconnect the Automatic Temperature Control (ATC) C1 harness connector.</p> <p>Disconnect the Cabin Heater or Heater Booster harness connector.</p> <p>Measure the resistance of the Cabin Heater Control circuit between the Automatic Temperature Control (ATC) C1 harness connector and the Cabin Heater or Heater Booster harness connector (as applicable).</p> <p>Is the resistance below 5.0 ohms?</p> <p>Yes → Replace the Automatic Temperature Control (ATC) in accordance with the Service Information. Perform BODY VERIFICATION TEST - VER 1.</p> <p>No → Repair the Cabin Heater Control circuit for an open. Perform BODY VERIFICATION TEST - VER 1.</p>	All

Symptom:

CABIN HEATER CONTROL SHORTED LOW (ACTIVE)

POSSIBLE CAUSES
CABIN HEATER OR HEATER BOOSTER CONTROL UNIT
CABIN HEATER CONTROL CIRCUIT SHORTED TO GROUND
CABIN HEATER CONTROL CIRCUIT SHORTED TO GROUND CIRCUIT
CABIN HEATER CONTROL CIRCUIT SHORTED TO SENSOR GROUND CIRCUIT
AUTOMATIC TEMPERATURE CONTROL (ATC)

TEST	ACTION	APPLICABILITY
1	<p>Turn the ignition off. Disconnect the Cabin Heater or Heater Booster harness connector. NOTE: All of the following criteria must be met in order to successfully run the ATC Function Test. Place the shift lever in Park. Turn the ignition on. With the DRBIII®, record and erase ATC DTC's. Start the engine. Allow the engine to reach normal operating temperature. Set the blower to high speed. Press the Air Conditioning switch On. With the DRBIII®, verify that the ambient temperature is above 59°F (15°C), the refrigerant pressure is between 29 and 348 PSI (2 and 24 bar), the evaporator temperature is above 36.5°F (2.5°C), and the coolant temperature is above 158°F (70°C). With the DRBIII® in Automatic Temperature Control (ATC), select System Tests and select ATC Function Test. When the ATC Function Test is complete, proceed as follows: With the DRBIII®, read the active ATC DTCs. Does the DRBIII® display: CABIN HEATER CONTROL SHORTED LOW?</p> <p style="padding-left: 40px;">Yes → Go To 2</p> <p style="padding-left: 40px;">No → Replace the Cabin Heater Assembly or the Heater Booster assembly in accordance with the Service Information. Perform BODY VERIFICATION TEST - VER 1.</p>	All
2	<p>Turn the ignition off. Disconnect the Cabin Heater or Heater Booster harness connector. Disconnect the Automatic Temperature Control (ATC) C1 harness connector. Measure the resistance between ground and the Cabin Heater Control circuit. Is the resistance below 30k ohms?</p> <p style="padding-left: 40px;">Yes → Repair the Cabin Heater Control circuit for a short to ground. Perform BODY VERIFICATION TEST - VER 1.</p> <p style="padding-left: 40px;">No → Go To 3</p>	All

CABIN HEATER CONTROL SHORTED LOW (ACTIVE) — Continued

TEST	ACTION	APPLICABILITY
3	<p>Turn the ignition off. Disconnect the Cabin Heater or Heater Booster harness connector. Disconnect the Automatic Temperature Control (ATC) C1 harness connector. Measure the resistance between the Cabin Heater Control circuit and the Ground circuit in the Automatic Temperature Control (ATC) C1 harness connector. Is the resistance below 30k ohms?</p> <p>Yes → Repair the Cabin Heater Control circuit for a short to the Ground circuit. Perform BODY VERIFICATION TEST - VER 1.</p> <p>No → Go To 4</p>	All
4	<p>Turn the ignition off. Disconnect the Cabin Heater or Heater Booster harness connector. Disconnect the Automatic Temperature Control (ATC) C1 harness connector. Measure the resistance between the Cabin Heater Control circuit and the Sensor Ground circuit in the Automatic Temperature Control (ATC) C1 harness connector. Is the resistance below 30k ohms?</p> <p>Yes → Repair the Cabin Heater Control circuit for a short to the Sensor Ground circuit. Perform BODY VERIFICATION TEST - VER 1.</p> <p>No → Replace the Automatic Temperature Control (ATC) in accordance with the Service Information. Perform BODY VERIFICATION TEST - VER 1.</p>	All

Symptom:

CIRC PUMP CONTROL HIGH OR OPEN (ACTIVE)

POSSIBLE CAUSES
<p>CIRCULATION PUMP</p> <p>CIRCULATION PUMP CONTROL CIRCUIT SHORTED TO VOLTAGE</p> <p>AUTOMATIC TEMPERATURE CONTROL (ATC)</p> <p>CIRCULATION PUMP CONTROL CIRCUIT OPEN</p> <p>GROUND CIRCUIT OPEN</p> <p>AUTOMATIC TEMPERATURE CONTROL (ATC)</p>

TEST	ACTION	APPLICABILITY
1	<p>Turn the ignition off.</p> <p>Press the Residual Engine Heat Utilization (REST) switch off.</p> <p>NOTE: Check connectors - Clean/repair as necessary.</p> <p>Disconnect the Circulation Pump harness connector.</p> <p>Connect a 12-volt test light between the Circulation Pump Control circuit and the Ground circuit in the Circulation Pump harness connector. The test light should operate as follows:</p> <p>With the Residual Engine Heat Utilization (REST) switch off, the test light should not illuminate.</p> <p>Press the Residual Engine Heat Utilization (REST) switch on. The test light should illuminate brightly.</p> <p>Does the test light function as specified?</p> <p style="padding-left: 40px;">Yes, Light Only Illuminates With REST On Replace the Circulation Pump in accordance with the Service Information. Perform BODY VERIFICATION TEST - VER 1.</p> <p style="padding-left: 40px;">No, Light Illuminates With REST Off Go To 2</p> <p style="padding-left: 40px;">No, Light Will Not Illuminate Go To 3</p>	All
2	<p>Turn the ignition off.</p> <p>NOTE: Check connectors - Clean/repair as necessary.</p> <p>Disconnect the Circulation Pump harness connector.</p> <p>Disconnect the Automatic Temperature Control (ATC) C1 harness connector.</p> <p>Turn the ignition on.</p> <p>Measure the voltage of the Circulation Pump Control circuit.</p> <p>Is the voltage above 0.2 volts?</p> <p style="padding-left: 40px;">Yes → Repair the Circulation Pump Control circuit for a short to voltage. Perform BODY VERIFICATION TEST - VER 1.</p> <p style="padding-left: 40px;">No → Replace the Automatic Temperature Control (ATC) in accordance with the Service Information. Perform BODY VERIFICATION TEST - VER 1.</p>	All

CIRC PUMP CONTROL HIGH OR OPEN (ACTIVE) — Continued

TEST	ACTION	APPLICABILITY
3	Turn the ignition off. NOTE: Check connectors - Clean/repair as necessary. Disconnect the Automatic Temperature Control (ATC) C1 harness connector. Disconnect the Circulation Pump harness connector. Measure the resistance of the Circulation Pump Control circuit between the Automatic Temperature Control (ATC) C1 harness connector and the Circulation Pump harness connector. Is the resistance below 5.0 ohms? Yes → Go To 4 No → Repair the Circulation Pump Control circuit for an open. Perform BODY VERIFICATION TEST - VER 1.	All
4	Turn the ignition off. NOTE: Check connectors - Clean/repair as necessary. Disconnect the Circulation Pump harness connector. Measure the resistance between ground and the Ground circuit. Is the resistance below 5.0 ohms? Yes → Replace the Automatic Temperature Control (ATC) in accordance with the Service Information. Perform BODY VERIFICATION TEST - VER 1. No → Repair the Ground circuit for an open. Perform BODY VERIFICATION TEST - VER 1.	All

Symptom:

CIRC PUMP CONTROL SHORTED LOW (ACTIVE)

POSSIBLE CAUSES
CIRCULATION PUMP CONTROL CIRCUIT SHORTED TO GROUND
CIRCULATION PUMP CONTROL CIRCUIT SHORTED TO GROUND CIRCUIT
CIRCULATION PUMP CONTROL CIRCUIT SHORTED TO SENSOR GROUND CIRCUIT
CIRCULATION PUMP
AUTOMATIC TEMPERATURE CONTROL (ATC)

TEST	ACTION	APPLICABILITY
1	Turn the ignition off. Disconnect the Circulation Pump harness connector. Disconnect the Automatic Temperature Control (ATC) C1 harness connector. Measure the resistance between ground and the Circulation Pump Control circuit. Is the resistance below 10k ohms? Yes → Repair the Circulation Pump Control circuit for a short to ground. Perform BODY VERIFICATION TEST - VER 1. No → Go To 2	All
2	Turn the ignition off. Disconnect the Circulation Pump harness connector. Disconnect the Automatic Temperature Control (ATC) C1 harness connector. Measure the resistance between the Circulation Pump Control circuit and the Ground circuit in the Automatic Temperature Control C1 harness connector. Is the resistance below 10k ohms? Yes → Repair the Circulation Pump Control circuit for a short to the Ground circuit. Perform BODY VERIFICATION TEST - VER 1. No → Go To 3	All
3	Turn the ignition off. Disconnect the Circulation Pump harness connector. Disconnect the Automatic Temperature Control (ATC) C1 harness connector. Measure the resistance between the Circulation Pump Control circuit and the Sensor Ground circuit in the Automatic Temperature Control C1 harness connector. Is the resistance below 10k ohms? Yes → Repair the Circulation Pump Control circuit for a short to the Sensor Ground circuit. Perform BODY VERIFICATION TEST - VER 1. No → Go To 4	All

CIRC PUMP CONTROL SHORTED LOW (ACTIVE) — Continued

TEST	ACTION	APPLICABILITY
4	Turn the ignition off. Disconnect the Circulation Pump harness connector. Connect a fused jumper wire between the Battery (+) and Circulation Pump cavity 2. Connect a jumper wire between ground and Circulation Pump cavity 1. Does the Circulation Pump run? Yes → Replace the Automatic Temperature Control (ATC) in accordance with the Service Information. Perform BODY VERIFICATION TEST - VER 1. No → Replace the Circulation Pump in accordance with the Service Information. Perform BODY VERIFICATION TEST - VER 1.	All

Symptom:

EVAP TEMP SENSOR HIGH OR OPEN (ACTIVE)

POSSIBLE CAUSES

EVAPORATOR TEMPERATURE SENSOR SIGNAL CIRCUIT SHORTED TO VOLTAGE
 AUTOMATIC TEMPERATURE CONTROL (ATC)
 AUTOMATIC TEMPERATURE CONTROL (ATC)
 EVAPORATOR TEMPERATURE SENSOR SIGNAL CIRCUIT OPEN
 SENSOR GROUND CIRCUIT OPEN
 EVAPORATOR TEMPERATURE SENSOR

TEST	ACTION	APPLICABILITY
1	Turn the ignition off. NOTE: Check connectors - Clean/repair as necessary. Disconnect the Evaporator Temperature Sensor harness connector. Turn the ignition on. While back probing, measure the voltage between the Evaporator Temperature Sensor Signal circuit and the Sensor Ground circuit. Is the voltage above 5.3 volts? Yes → Go To 2 No → Go To 3	All
2	Turn the ignition off. NOTE: Check connectors - Clean/repair as necessary. Disconnect the Evaporator Temperature Sensor harness connector. Disconnect the Automatic Temperature Control (ATC) C1 harness connector. Turn the ignition on. Measure the voltage of the Evaporator Temperature Sensor Signal circuit. Is the voltage above 0.2 volts? Yes → Repair the Evaporator Temperature Sensor Signal circuit for a short to voltage. Perform BODY VERIFICATION TEST - VER 1. No → Replace the Automatic Temperature Control (ATC) in accordance with the Service Information. Perform BODY VERIFICATION TEST - VER 1.	All
3	Turn the ignition off. NOTE: Check connectors - Clean/repair as necessary. Disconnect the Evaporator Temperature Sensor harness connector. Turn the ignition on. While back probing, measure the voltage between the Evaporator Temperature Sensor Signal circuit and Sensor Ground circuit in the Automatic Temperature Control (ATC) C1 harness connector. Is the voltage above 4.5 volts? Yes → Go To 4 No → Replace the Automatic Temperature Control (ATC) in accordance with the Service Information. Perform BODY VERIFICATION TEST - VER 1.	All

EVAP TEMP SENSOR HIGH OR OPEN (ACTIVE) — Continued

TEST	ACTION	APPLICABILITY
4	Turn the ignition off. NOTE: Check connectors - Clean/repair as necessary. Disconnect the Automatic Temperature Control (ATC) C1 harness connector. Disconnect the Evaporator Temperature Sensor harness connector. Measure the resistance of the Evaporator Temperature Sensor Signal circuit between the Automatic Temperature Control (ATC) C1 harness connector and the Evaporator Temperature Sensor harness connector. Is the resistance below 5.0 ohms? Yes → Go To 5 No → Repair the Evaporator Temperature Sensor Signal circuit for an open. Perform BODY VERIFICATION TEST - VER 1.	All
5	Turn the ignition off. NOTE: Check connectors - Clean/repair as necessary. Disconnect the Automatic Temperature Control (ATC) C1 harness connector. Disconnect the Evaporator Temperature Sensor harness connector. Measure the resistance of the Sensor Ground circuit between the Automatic Temperature Control (ATC) C1 harness connector and the Evaporator Temperature Sensor harness connector. Is the resistance below 5.0 ohms? Yes → Replace the Evaporator Temperature Sensor in accordance with the Service Information. Perform BODY VERIFICATION TEST - VER 1. No → Repair the Sensor Ground circuit for an open. Perform BODY VERIFICATION TEST - VER 1.	All

Symptom:

EVAP TEMP SENSOR SHORTED LOW (ACTIVE)

POSSIBLE CAUSES
EVAPORATOR TEMPERATURE SENSOR EVAP TEMP SENSOR SIGNAL CIRCUIT SHORTED TO GROUND EVAP TEMP SENSOR SIGNAL CIRCUIT SHORTED TO GROUND CIRCUIT EVAP TEMP SENSOR SIGNAL CIRCUIT SHORTED TO SENSOR GROUND CIRCUIT AUTOMATIC TEMPERATURE CONTROL (ATC)

TEST	ACTION	APPLICABILITY
1	Turn the ignition off. Disconnect the Evaporator Temperature Sensor harness connector. Turn the ignition on. With the DRBIII®, record and erase Automatic Temperature Control DTCs. Turn the ignition off, wait 5 seconds, then turn the ignition on. With the DRBIII®, read the Automatic Temperature Control DTCs. Does the DRBIII® display: EVAP TEMP SENSOR HIGH OR OPEN? Yes → Replace the Evaporator Temperature Sensor in accordance with the Service Information. Perform BODY VERIFICATION TEST - VER 1. No → Go To 2	All
2	Turn the ignition off. Disconnect the Automatic Temperature Control (ATC) C1 harness connector. Measure the resistance between ground and the Evaporator Temperature Sensor Signal circuit. Is the resistance below 10k ohms? Yes → Repair the Evaporator Temperature Sensor Signal circuit for a short to ground. Perform BODY VERIFICATION TEST - VER 1. No → Go To 3	All
3	Turn the ignition off. Disconnect the Automatic Temperature Control (ATC) C1 harness connector. Measure the resistance between the Evaporator Temperature Sensor Signal circuit and the Ground circuit. Is the resistance below 10k ohms? Yes → Repair the Evaporator Temperature Sensor Signal circuit for a short to the Ground circuit. Perform BODY VERIFICATION TEST - VER 1. No → Go To 4	All

EVAP TEMP SENSOR SHORTED LOW (ACTIVE) — Continued

TEST	ACTION	APPLICABILITY
4	<p>Turn the ignition off. Disconnect the Automatic Temperature Control (ATC) C1 harness connector. Disconnect the Evaporator Temperature Sensor harness connector. Measure the resistance between the Evaporator Temperature Sensor Signal circuit and the Sensor Ground circuit. Is the resistance below 10k ohms?</p> <p>Yes → Repair the Evaporator Temperature Sensor Signal circuit for a short to the Sensor Ground circuit. Perform BODY VERIFICATION TEST - VER 1.</p> <p>No → Replace the Automatic Temperature Control (ATC) in accordance with the Service Information. Perform BODY VERIFICATION TEST - VER 1.</p>	All

Symptom:
NO COMMUNICATION BUS (ACTIVE)

When Monitored and Set Condition:

NO COMMUNICATION BUS (ACTIVE)

When Monitored: With the ignition on.

Set Condition: This DTC will set if the Automatic Temperature Control (ATC) fails to receive all module messages.

POSSIBLE CAUSES

CAN CIRCUITS SHORTED TO VOLTAGE
 MODULE SHORT TO VOLTAGE
 CAN CIRCUITS SHORTED TO GROUND
 MODULE SHORT TO GROUND
 CAN CIRCUITS SHORTED TOGETHER
 ENGINE CONTROL MODULE
 SENTRY KEY REMOTE ENTRY MODULE

TEST	ACTION	APPLICABILITY
1	Turn the ignition off. Disconnect the Instrument Cluster harness connectors. Turn the ignition on. Measure the voltage between CAN C Bus (+) circuit and ground. Measure the voltage between CAN C Bus (-) circuit and ground. Is the voltage above 3.0 volts on either circuit? Yes → Go To 2 No → Go To 3	All

NO COMMUNICATION BUS (ACTIVE) — Continued

TEST	ACTION	APPLICABILITY
2	<p>Turn the ignition off. Using a voltmeter, connect one end to the CAN circuit that previously measured above 3.0 volts, and the other end to ground. NOTE: Refer to the wiring diagrams in the service information to help determine which modules are connected to the CAN Bus. NOTE: Wait one minute, after turning the ignition off, before disconnecting the module. Disconnect a module that is connected to the CAN bus. Turn the ignition on. Monitor and note the voltmeter reading. Repeat this procedure until either the voltage reading drops below 3.0 volts or all modules that are connected to the CAN Bus are disconnected and the voltage reading remains above 3.0 volts. Then, proceed to the conclusion question. What is the outcome?</p> <ul style="list-style-type: none"> > 3.0 volts w/all modules disconnected Repair the CAN C Bus (+) circuit or the CAN C Bus (-) circuit for a short to voltage. Perform BODY VERIFICATION TEST - VER 1. < 3.0 volts after disconnecting a module Replace the module that caused the voltage reading to drop after disconnecting it. Perform BODY VERIFICATION TEST - VER 1. 	All
3	<p>Turn the ignition off. Disconnect the Instrument Cluster harness connectors. Disconnect the negative battery cable. Measure the resistance between ground and the CAN C Bus (+) circuit. Measure the resistance between ground and the CAN C Bus (-) circuit. Is the resistance below 50.0 ohms on either circuit?</p> <ul style="list-style-type: none"> Yes → Go To 4 No → Go To 5 	All
4	<p>Turn the ignition off. Disconnect the negative battery cable. Using an ohmmeter, connect one end to the CAN Bus circuit that previously measured below 50.0 ohms and the other end to ground. NOTE: Refer to the wiring diagrams in the service information to help determine which modules are connected to the CAN Bus. Disconnect a module that is connected to the CAN Bus. Monitor and note the ohmmeter reading. Repeat this procedure until either the resistance reading goes above 50.0 ohms or all modules that are connected to the CAN Bus are disconnected and the resistance reading remains below 50.0 ohms. Then, proceed to the conclusion question. What is the outcome?</p> <ul style="list-style-type: none"> < 50.0 ohms w/all modules disconnected Repair the CAN C Bus (+) circuit or the CAN C Bus (-) circuit for a short to ground. Perform BODY VERIFICATION TEST - VER 1. >50.0 ohms after disconnecting a module Replace the module that caused the resistance reading to increase after disconnecting it. Perform BODY VERIFICATION TEST - VER 1. 	All

NO COMMUNICATION BUS (ACTIVE) — Continued

TEST	ACTION	APPLICABILITY
5	<p>Turn the ignition off. Disconnect the negative battery cable. NOTE: Refer to the wiring diagrams in the service information to help determine which modules are connected to the CAN Bus. Disconnect all of the modules that are connected to the CAN Bus. Measure the resistance between the CAN C Bus (+) circuit and the CAN C Bus (-) circuit at any disconnected module's harness connector. Is the resistance below 10k ohms?</p> <p>Yes → Repair the CAN C Bus (+) circuit for a short to the CAN C Bus (-) circuit. Perform BODY VERIFICATION TEST - VER 1.</p> <p>No → Go To 6</p>	All
6	<p>Turn the ignition off. Reconnect the Engine Control Module harness connectors. While back probing, measure the resistance of the CAN C Bus (+) circuit and the CAN C Bus (-) circuit at the ECM harness connector. Is the resistance 120.0 ± 2.0 ohms?</p> <p>Yes → Replace the Sentry Key Remote Entry Module in accordance with the Service Information. Perform BODY VERIFICATION TEST - VER 1.</p> <p>No → Replace the Engine Control Module in accordance with the Service Information. Perform BODY VERIFICATION TEST - VER 1.</p>	All

Symptom:**NO COMMUNICATION WITH ECM (ACTIVE)****When Monitored and Set Condition:****NO COMMUNICATION WITH ECM (ACTIVE)**

When Monitored: With the ignition on.

Set Condition: This DTC will set if the Automatic Temperature Control (ATC) fails to receive all messages from the ECM.

POSSIBLE CAUSES

CAN C BUS CIRCUIT(S) SHORTED OR OPEN

ENGINE CONTROL MODULE DTC(S) PRESENT

ENGINE CONTROL MODULE'S POWER/GROUND CIRCUIT(S) SHORTED OR OPEN

ENGINE CONTROL MODULE

CAN C BUS (+)/CAN C BUS (-) CIRCUIT(S) OPEN TO ENGINE CONTROL MODULE

AUTOMATIC TEMPERATURE CONTROL (ATC)

CAN C BUS (+)/CAN C BUS (-) CIRCUIT(S) OPEN TO AUTOMATIC TEMPERATURE CONTROL

TEST	ACTION	APPLICABILITY
1	Turn the ignition on. With the DRBIII®, read Automatic Temperature Control DTCs. Does the DRBIII® display: NO COMMUNICATION BUS? Yes → Refer to the Communication category for the related symptom. Perform BODY VERIFICATION TEST - VER 1. No → Go To 2	All
2	Turn the ignition on. With the DRBIII®, read Engine Control Module DTCs. Does the DRBIII® display any DTCs? Yes → Refer to Powertrain Diagnostic information for the related symptom(s). Perform BODY VERIFICATION TEST - VER 1. No → Go To 3	All
3	Turn the ignition on. With the DRBIII®, check the TCM, IC, and ABS module for the same or similar No Communication with Engine Control Module DTC. Does the DRBIII® display same or similar DTC in TCM, IC, & ABS module? Yes → Go To 4 No → Go To 6	All

NO COMMUNICATION WITH ECM (ACTIVE) — Continued

TEST	ACTION	APPLICABILITY
4	Turn the ignition off. Disconnect the Engine Control Module harness connectors. Check all of the engine control module's power circuits for a short or open condition. Check all of the engine control module's ground circuits for an open condition. Were any problems found? Yes → Repair the power/ground circuit(s) as necessary. Perform BODY VERIFICATION TEST - VER 1. No → Go To 5	All
5	Turn the ignition off. Disconnect the Engine Control Module harness connectors. Measure the resistance between the CAN C Bus (+) circuit and the CAN C Bus (-) circuit in the Engine Control Module harness connector. Is the resistance 57 to 63 ohms? Yes → Replace the Engine Control Module in accordance with the Service Information. Perform BODY VERIFICATION TEST - VER 1. No → Repair the CAN C Bus (+)/CAN C Bus (-) circuit(s) for an open. Perform BODY VERIFICATION TEST - VER 1.	All
6	Turn the ignition off. Disconnect the Automatic Temperature Control (ATC) C1 harness connector. Measure the resistance between the CAN C Bus (+) circuit and the CAN C Bus (-) circuit in the Automatic Temperature Control (ATC) C1 harness connector. Is the resistance 57 to 63 ohms? Yes → Replace the Automatic Temperature Control in accordance with the Service Information. Perform BODY VERIFICATION TEST - VER 1. No → Repair the CAN C Bus (+)/CAN C Bus (-) circuit(s) for an open. Perform BODY VERIFICATION TEST - VER 1.	All

Symptom:**NO COMMUNICATION WITH IC (ACTIVE)****When Monitored and Set Condition:****NO COMMUNICATION WITH IC (ACTIVE)**

When Monitored: With the ignition on.

Set Condition: This DTC will set if the Automatic Temperature Control (ATC) fails to receive all messages from the Instrument Cluster.

POSSIBLE CAUSES

CAN C BUS CIRCUIT(S) SHORTED OR OPEN
 INSTRUMENT CLUSTER DTC(S) PRESENT
 INSTRUMENT CLUSTER'S POWER/GROUND CIRCUIT(S) SHORTED OR OPEN
 INSTRUMENT CLUSTER
 CAN C BUS (+)/CAN C BUS (-) CIRCUIT(S) OPEN TO INSTRUMENT CLUSTER
 AUTOMATIC TEMPERATURE CONTROL (ATC)
 CAN C BUS (+)/CAN C BUS (-) CIRCUIT(S) OPEN TO AUTOMATIC TEMPERATURE CONTROL

TEST	ACTION	APPLICABILITY
1	Turn the ignition on. With the DRBIII®, read Automatic Temperature Control DTCs. Does the DRBIII® display: NO COMMUNICATION BUS? Yes → Refer to the Communication category for the related symptom. Perform BODY VERIFICATION TEST - VER 1. No → Go To 2	All
2	Turn the ignition on. With the DRBIII®, read Instrument Cluster DTCs. Does the DRBIII® display any DTCs? Yes → Refer to Instrument Cluster category for the related symptom(s). Perform BODY VERIFICATION TEST - VER 1. No → Go To 3	All
3	Turn the ignition on. With the DRBIII®, check the TCM and ABS module for the same or similar No Communication with Instrument Cluster DTC. Does the DRBIII® display same or similar DTC in TCM & ABS module? Yes → Go To 4 No → Go To 6	All

NO COMMUNICATION WITH IC (ACTIVE) — Continued

TEST	ACTION	APPLICABILITY
4	Turn the ignition off. Disconnect the Instrument Cluster harness connectors. Check all of the instrument cluster's power circuits for a short or open condition. Check all of the instrument cluster's ground circuits for an open condition. Were any problems found? Yes → Repair the power/ground circuit(s) as necessary. Perform BODY VERIFICATION TEST - VER 1. No → Go To 5	All
5	Turn the ignition off. Disconnect the Instrument Cluster harness connectors. Measure the resistance between the CAN C Bus (+) circuit and the CAN C Bus (-) circuit in the Instrument Cluster harness connector. Is the resistance 57 to 63 ohms? Yes → Replace the Instrument Cluster in accordance with the Service Information. Perform BODY VERIFICATION TEST - VER 1. No → Repair the CAN C Bus (+)/CAN C Bus (-) circuit(s) for an open. Perform BODY VERIFICATION TEST - VER 1.	All
6	Turn the ignition off. Disconnect the Automatic Temperature Control (ATC) C1 harness connector. Measure the resistance between the CAN C Bus (+) circuit and the CAN C Bus (-) circuit in the Automatic Temperature Control (ATC) C1 harness connector. Is the resistance 57 to 63 ohms? Yes → Replace the Automatic Temperature Control in accordance with the Service Information. Perform BODY VERIFICATION TEST - VER 1. No → Repair the CAN C Bus (+)/CAN C Bus (-) circuit(s) for an open. Perform BODY VERIFICATION TEST - VER 1.	All

Symptom:**RECIRC AIR SOLENOID CONTROL HIGH OR OPEN (ACTIVE)****POSSIBLE CAUSES**

RECIRCULATED AIR SOLENOID VALVE

RECIRCULATED AIR SOLENOID VALVE CONTROL CIRCUIT SHORTED TO VOLTAGE

AUTOMATIC TEMPERATURE CONTROL (ATC)

RECIRCULATED AIR SOLENOID VALVE CONTROL CIRCUIT OPEN

GROUND CIRCUIT OPEN

AUTOMATIC TEMPERATURE CONTROL (ATC)

TEST	ACTION	APPLICABILITY
1	Turn the ignition on. Press the Air Recirculation switch off. Turn the ignition off. NOTE: Check connectors - Clean/repair as necessary. Disconnect the Recirculated Air Solenoid Valve harness connector. Connect a 12-volt test light between the Recirculated Air Solenoid Valve Control circuit and the Ground circuit in the Recirculated Air Solenoid harness connector. Turn the ignition on. The test light should operate as follows: With the Air Recirculation switch off, the test light should not illuminate. Press the Air Recirculation switch on. The test light should illuminate brightly. Does the test light function as specified? Yes, Light Only Illuminates w/Recirc On Replace the Recirculated Air Solenoid Valve in accordance with the Service Information. Perform BODY VERIFICATION TEST - VER 1. No, Light Illuminates w/Recirc Off Go To 2 No, Light Will Not Illuminate Go To 3	All
2	Turn the ignition off. NOTE: Check connectors - Clean/repair as necessary. Disconnect the Recirculated Air Solenoid Valve harness connector. Disconnect the Automatic Temperature Control (ATC) C1 harness connector. Turn the ignition on. Measure the voltage of the Recirculated Air Solenoid Valve Control circuit. Is the voltage above 0.2 volts? Yes → Repair the Recirculated Air Solenoid Valve Control circuit for a short to voltage. Perform BODY VERIFICATION TEST - VER 1. No → Replace the Automatic Temperature Control (ATC) in accordance with the Service Information. Perform BODY VERIFICATION TEST - VER 1.	All

RECIRC AIR SOLENOID CONTROL HIGH OR OPEN (ACTIVE) — Continued

TEST	ACTION	APPLICABILITY
3	<p>Turn the ignition off.</p> <p>NOTE: Check connectors - Clean/repair as necessary.</p> <p>Disconnect the Automatic Temperature Control (ATC) C1 harness connector.</p> <p>Disconnect the Recirculated Air Solenoid Valve harness connector.</p> <p>Measure the resistance of the Recirculated Air Solenoid Valve Control circuit between the Automatic Temperature Control (ATC) C1 harness connector and the Recirculated Air Solenoid Valve harness connector.</p> <p>Is the resistance below 5.0 ohms?</p> <p>Yes → Go To 4</p> <p>No → Repair the Recirculated Air Solenoid Valve Control circuit for an open.</p> <p>Perform BODY VERIFICATION TEST - VER 1.</p>	All
4	<p>Turn the ignition off.</p> <p>NOTE: Check connectors - Clean/repair as necessary.</p> <p>Disconnect the Recirculated Air Solenoid Valve harness connector.</p> <p>Measure the resistance between ground and the Ground circuit.</p> <p>Is the resistance below 5.0 ohms?</p> <p>Yes → Replace the Automatic Temperature Control (ATC) in accordance with the Service Information.</p> <p>Perform BODY VERIFICATION TEST - VER 1.</p> <p>No → Repair the Ground circuit for an open.</p> <p>Perform BODY VERIFICATION TEST - VER 1.</p>	All

Symptom:**RECIRC AIR SOLENOID CONTROL SHORTED LOW (ACTIVE)****POSSIBLE CAUSES**

RECIRCULATED AIR SOLENOID VALVE CONTROL CIRCUIT SHORTED TO GROUND
 RECIRCULATED AIR SOLENOID VALVE CONTROL CIRCUIT SHORTED TO GROUND CIRCUIT
 RECIRCULATED AIR SOLENOID VALVE CONTROL CIRCUIT SHORTED TO SENSOR GROUND CIRCUIT
 AUTOMATIC TEMPERATURE CONTROL (ATC)
 RECIRCULATED AIR SOLENOID VALVE

TEST	ACTION	APPLICABILITY
1	Turn the ignition off. Disconnect the Recirculated Air Solenoid Valve harness connector. Disconnect the Automatic Temperature Control (ATC) C1 harness connector. Measure the resistance between ground and the Recirculated Air Solenoid Valve Control circuit. Is the resistance below 10k ohms? Yes → Repair the Recirculated Air Solenoid Valve Control circuit for a short to ground. Perform BODY VERIFICATION TEST - VER 1. No → Go To 2	All
2	Turn the ignition off. Disconnect the Recirculated Air Solenoid Valve harness connector. Disconnect the Automatic Temperature Control (ATC) C1 harness connector. Measure the resistance between the Recirculated Air Solenoid Valve Control circuit and the Ground circuit in the Automatic Temperature Control C1 harness connector. Is the resistance below 10k ohms? Yes → Repair the Recirculated Air Solenoid Valve Control circuit for a short to the Ground circuit. Perform BODY VERIFICATION TEST - VER 1. No → Go To 3	All
3	Turn the ignition off. Disconnect the Recirculated Air Solenoid Valve harness connector. Disconnect the Automatic Temperature Control (ATC) C1 harness connector. Measure the resistance between the Recirculated Air Solenoid Valve Control circuit and the Sensor Ground circuit in the Automatic Temperature Control C1 harness connector. Is the resistance below 10k ohms? Yes → Repair the Recirculated Air Solenoid Valve Control circuit for a short to the Sensor Ground circuit. Perform BODY VERIFICATION TEST - VER 1. No → Go To 4	All

RECIRC AIR SOLENOID CONTROL SHORTED LOW (ACTIVE) — Continued

TEST	ACTION	APPLICABILITY
4	<p>Turn the ignition off.</p> <p>NOTE: Check connectors - Clean/repair as necessary.</p> <p>Reconnect the Automatic Temperature Control (ATC) C1 harness connector.</p> <p>Disconnect the Recirculated Air Solenoid Valve harness connector.</p> <p>Turn the ignition on.</p> <p>Press the Air Recirculation switch off.</p> <p>Turn the ignition off.</p> <p>Connect a 12-volt test light between the Recirculated Air Solenoid Valve Control circuit and the Ground circuit in the Recirculated Air Solenoid harness connector.</p> <p>Turn the ignition on. The test light should operate as follows:</p> <p>With the Air Recirculation switch off, the test light should not illuminate.</p> <p>Press the Air Recirculation switch on. The test light should illuminate brightly.</p> <p>Does the test light function as specified?</p> <p>Yes → Replace the Recirculated Air Solenoid Valve in accordance with the Service Information. Perform BODY VERIFICATION TEST - VER 1.</p> <p>No → Replace the Automatic Temperature Control (ATC) in accordance with the Service Information. Perform BODY VERIFICATION TEST - VER 1.</p>	All

Symptom:**REFRIG PRESS SENSOR HIGH OR OPEN (ACTIVE)****POSSIBLE CAUSES**

5 VOLT SUPPLY CIRCUIT SHORTED TO VOLTAGE
 REFRIGERANT PRESSURE SENSOR FEEDBACK CIRCUIT SHORTED TO VOLTAGE
 5 VOLT SUPPLY CKT SHORTED TO REFRIGERANT PRESSURE SENSOR FEEDBACK CKT
 AUTOMATIC TEMPERATURE CONTROL (ATC)
 5 VOLT SUPPLY CIRCUIT OPEN
 REFRIGERANT PRESSURE SENSOR FEEDBACK CIRCUIT OPEN
 SENSOR GROUND CIRCUIT OPEN
 REFRIGERANT PRESSURE SENSOR

TEST	ACTION	APPLICABILITY
1	Turn the ignition off. NOTE: Check connectors - Clean/repair as necessary. Disconnect the Automatic Temperature Control (ATC) C1 harness connector. Turn the ignition on. Measure the voltage of the 5 Volt Supply circuit. Is the voltage above 0.2 volts? Yes → Repair the 5 Volt Supply circuit for a short to voltage. Perform BODY VERIFICATION TEST - VER 1. No → Go To 2	All
2	Turn the ignition off. NOTE: Check connectors - Clean/repair as necessary. Disconnect the Automatic Temperature Control (ATC) C1 harness connector. Turn the ignition on. Measure the voltage of the Refrigerant Pressure Sensor Feedback circuit. Is the voltage above 0.2 volts? Yes → Repair the Refrigerant Pressure Sensor Feedback circuit for a short to voltage. Perform BODY VERIFICATION TEST - VER 1. No → Go To 3	All
3	Turn the ignition off. NOTE: Check connectors - Clean/repair as necessary. Disconnect the Refrigerant Pressure Sensor harness connector. Disconnect the Automatic Temperature Control (ATC) C1 harness connector. Measure the resistance between the 5 Volt Supply circuit and the Refrigerant Pressure Sensor Feedback circuit. Is the resistance below 10k ohms? Yes → Repair the 5 Volt Supply circuit for a short to the Refrigerant Pressure Sensor Feedback circuit. Perform BODY VERIFICATION TEST - VER 1. No → Go To 4	All

REFRIG PRESS SENSOR HIGH OR OPEN (ACTIVE) — Continued

TEST	ACTION	APPLICABILITY
4	<p>Turn the ignition off. NOTE: Check connectors - Clean/repair as necessary. Reconnect the Automatic Temperature Control (ATC) C1 harness connector. Turn the ignition on. While back probing, measure the voltage between the 5 Volt Supply circuit and ground. While back probing, measure the voltage between the Refrigerant Pressure Sensor Feedback circuit and ground. Is the voltage above 5.3 volts on either circuit?</p> <p style="padding-left: 40px;">Yes → Replace the Automatic Temperature Control (ATC) in accordance with the Service Information. Perform BODY VERIFICATION TEST - VER 1.</p> <p style="padding-left: 40px;">No → Go To 5</p>	All
5	<p>Turn the ignition off. NOTE: Check connectors - Clean/repair as necessary. Disconnect the Refrigerant Pressure Sensor harness connector. Disconnect the Automatic Temperature Control (ATC) C1 harness connector. Measure the resistance of the 5 Volt Supply circuit between the Automatic Temperature Control (ATC) C1 harness connector and the Refrigerant Pressure Sensor harness connector. Is the resistance below 5.0 ohms?</p> <p style="padding-left: 40px;">Yes → Go To 6</p> <p style="padding-left: 40px;">No → Repair the 5 Volt Supply circuit for an open. Perform BODY VERIFICATION TEST - VER 1.</p>	All
6	<p>Turn the ignition off. NOTE: Check connectors - Clean/repair as necessary. Disconnect the Refrigerant Pressure Sensor harness connector. Disconnect the Automatic Temperature Control (ATC) C1 harness connector. Measure the resistance of the Refrigerant Pressure Sensor Feedback circuit between the Automatic Temperature Control (ATC) C1 harness connector and the Refrigerant Pressure Sensor harness connector. Is the resistance below 5.0 ohms?</p> <p style="padding-left: 40px;">Yes → Go To 7</p> <p style="padding-left: 40px;">No → Repair the Refrigerant Pressure Sensor Feedback circuit for an open. Perform BODY VERIFICATION TEST - VER 1.</p>	All
7	<p>Turn the ignition off. NOTE: Check connectors - Clean/repair as necessary. Disconnect the Refrigerant Pressure Sensor harness connector. Disconnect the Automatic Temperature Control (ATC) C1 harness connector. Measure the resistance of the Sensor Ground circuit between the Automatic Temperature Control (ATC) C1 harness connector and the Refrigerant Pressure Sensor harness connector. Is the resistance below 5.0 ohms?</p> <p style="padding-left: 40px;">Yes → Replace the Refrigerant Pressure Sensor in accordance with the Service Information. Perform BODY VERIFICATION TEST - VER 1.</p> <p style="padding-left: 40px;">No → Repair the Sensor Ground circuit for an open. Perform BODY VERIFICATION TEST - VER 1.</p>	All

Symptom:**REFRIG PRESS SENSOR SHORTED LOW (ACTIVE)****POSSIBLE CAUSES**

REFRIGERANT PRESSURE SENSOR

5 VOLT SUPPLY CIRCUIT SHORTED TO GROUND

5 VOLT SUPPLY CIRCUIT SHORTED TO GROUND CIRCUIT

5 VOLT SUPPLY CIRCUIT SHORTED TO SENSOR GROUND CIRCUIT

REFRIGERANT PRESSURE SENSOR FEEDBACK CIRCUIT SHORTED TO GROUND

REFRIGERANT PRESSURE SENSOR FEEDBACK CIRCUIT SHORTED TO GROUND CIRCUIT

REFRIGERANT PRESSURE SENSOR FEEDBACK CIRCUIT SHORTED TO SENSOR GROUND CIRCUIT

AUTOMATIC TEMPERATURE CONTROL (ATC)

TEST	ACTION	APPLICABILITY
1	Turn the ignition off. Disconnect the Refrigerant Pressure Sensor harness connector. NOTE: All of the following criteria must be met in order to successfully run the ATC Function Test. Place the shift lever in Park. Turn the ignition on. With the DRBIII®, record and erase ATC DTC's. Start the engine. Allow the engine to reach normal operating temperature. Set the blower to high speed. Press the Air Conditioning switch On. With the DRBIII®, verify that the ambient temperature is above 59°F (15°C), the refrigerant pressure is between 29 and 348 PSI (2 and 24 bar), the evaporator temperature is above 36.5°F (2.5°C), and the coolant temperature is above 158°F (70°C). With the DRBIII® in Automatic Temperature Control (ATC), select System Tests and select ATC Function Test. When the ATC Function Test is complete, proceed as follows: With the DRBIII®, read the active ATC DTCs. Does the DRBIII® display: REFRIG PRESS SENSOR SHORTED LOW? Yes → Go To 2 No → Replace the Refrigerant Pressure Sensor in accordance with the Service Information. Perform BODY VERIFICATION TEST - VER 1.	All
2	Turn the ignition off. Disconnect the Automatic Temperature Control (ATC) C1 harness connector. Measure the resistance between ground and the 5 Volt Supply circuit. Is the resistance below 10k ohms? Yes → Repair the 5 Volt Supply circuit for a short to ground. Perform BODY VERIFICATION TEST - VER 1. No → Go To 3	All

REFRIG PRESS SENSOR SHORTED LOW (ACTIVE) — Continued

TEST	ACTION	APPLICABILITY
3	<p>Turn the ignition off. Disconnect the Automatic Temperature Control (ATC) C1 harness connector. Measure the resistance between the 5 Volt Supply circuit and the Ground circuit. Is the resistance below 10k ohms?</p> <p>Yes → Repair the 5 Volt Supply circuit for a short to the Ground circuit. Perform BODY VERIFICATION TEST - VER 1.</p> <p>No → Go To 4</p>	All
4	<p>Turn the ignition off. Disconnect the Refrigerant Pressure Sensor harness connector. Disconnect the Automatic Temperature Control (ATC) C1 harness connector. Measure the resistance between the 5 Volt Supply circuit and the Sensor Ground circuit. Is the resistance below 10k ohms?</p> <p>Yes → Repair the 5 Volt Supply circuit for a short to the Sensor Ground circuit. Perform BODY VERIFICATION TEST - VER 1.</p> <p>No → Go To 5</p>	All
5	<p>Turn the ignition off. Disconnect the Automatic Temperature Control (ATC) C1 harness connector. Measure the resistance between ground and the Refrigerant Pressure Sensor Feedback circuit. Is the resistance below 10k ohms?</p> <p>Yes → Repair the Refrigerant Pressure Sensor Feedback circuit for a short to ground. Perform BODY VERIFICATION TEST - VER 1.</p> <p>No → Go To 6</p>	All
6	<p>Turn the ignition off. Disconnect the Automatic Temperature Control (ATC) C1 harness connector. Measure the resistance between the Refrigerant Pressure Sensor Feedback circuit and the Ground circuit. Is the resistance below 10k ohms?</p> <p>Yes → Repair the Refrigerant Pressure Sensor Feedback circuit for a short to the Ground circuit. Perform BODY VERIFICATION TEST - VER 1.</p> <p>No → Go To 7</p>	All
7	<p>Turn the ignition off. Disconnect the Refrigerant Pressure Sensor harness connector. Disconnect the Automatic Temperature Control (ATC) C1 harness connector. Measure the resistance between the Refrigerant Pressure Sensor Feedback circuit and the Sensor Ground circuit. Is the resistance below 10k ohms?</p> <p>Yes → Repair the Refrigerant Pressure Sensor Feedback circuit for a short to the Sensor Ground circuit. Perform BODY VERIFICATION TEST - VER 1.</p> <p>No → Replace the Automatic Temperature Control (ATC) in accordance with the Service Information. Perform BODY VERIFICATION TEST - VER 1.</p>	All

Symptom:**WATER CYCLE VALVE CONTROL HIGH OR OPEN (ACTIVE)****POSSIBLE CAUSES**

WATER CYCLE VALVE
 WATER CYCLE VALVE CONTROL CIRCUIT SHORTED TO VOLTAGE
 AUTOMATIC TEMPERATURE CONTROL (ATC)
 WATER CYCLE VALVE CONTROL CIRCUIT OPEN
 GROUND CIRCUIT OPEN
 AUTOMATIC TEMPERATURE CONTROL (ATC)

TEST	ACTION	APPLICABILITY
1	<p>Turn the ignition off. Press the Residual Engine Heat Utilization (REST) switch off. NOTE: Check connectors - Clean/repair as necessary. Disconnect the Water Cycle Valve harness connector. Connect a 12-volt test light between the Water Cycle Valve Control circuit and the Ground circuit in the Water Cycle Valve harness connector. The test light should operate as follows: With the Residual Engine Heat Utilization (REST) switch off, the test light should not illuminate. Press the Residual Engine Heat Utilization (REST) switch on. With the Blend control set to Full Cold, the test light should illuminate brightly and continuously. With the Blend control set to one position below the half Cold/Hot setting, the test light should illuminate brightly and blink at a slow continuous rate. With the Blend control set to the half Cold/Hot setting or above, the test light should be off. Does the test light operate as specified?</p> <p>Yes → Replace the Water Cycle Valve in accordance with the Service Information. Perform BODY VERIFICATION TEST - VER 1.</p> <p>No, Light Illuminates With REST Off. Go To 2</p> <p>No, Light Will Not Illuminate Go To 3</p> <p>No, Light Won't Correspond To Blend Go To 3</p>	All

WATER CYCLE VALVE CONTROL HIGH OR OPEN (ACTIVE) — Continued

TEST	ACTION	APPLICABILITY
2	<p>Turn the ignition off. NOTE: Check connectors - Clean/repair as necessary. Disconnect the Automatic Temperature Control (ATC) C1 harness connector. Turn the ignition on. Measure the voltage of the Water Cycle Valve Control circuit. Is the voltage above 0.2 volts?</p> <p style="padding-left: 40px;">Yes → Repair the Water Cycle Valve Control circuit for a short to voltage. Perform BODY VERIFICATION TEST - VER 1.</p> <p style="padding-left: 40px;">No → Replace the Automatic Temperature Control (ATC) in accordance with the Service Information. Perform BODY VERIFICATION TEST - VER 1.</p>	All
3	<p>Turn the ignition off. NOTE: Check connectors - Clean/repair as necessary. Disconnect the Automatic Temperature Control (ATC) C1 harness connector. Disconnect the Water Cycle Valve harness connector. Measure the resistance of the Water Cycle Valve Control circuit between the Automatic Temperature Control (ATC) C1 harness connector and the Water Cycle Valve harness connector. Is the resistance below 5.0 ohms?</p> <p style="padding-left: 40px;">Yes → Go To 4</p> <p style="padding-left: 40px;">No → Repair the Water Cycle Valve Control circuit for an open. Perform BODY VERIFICATION TEST - VER 1.</p>	All
4	<p>Turn the ignition off. NOTE: Check connectors - Clean/repair as necessary. Disconnect the Water Cycle Valve harness connector. Measure the resistance between ground and the Ground circuit. Is the resistance below 5.0 ohms?</p> <p style="padding-left: 40px;">Yes → Replace the Automatic Temperature Control (ATC) in accordance with the Service Information. Perform BODY VERIFICATION TEST - VER 1.</p> <p style="padding-left: 40px;">No → Repair the Ground circuit for an open. Perform BODY VERIFICATION TEST - VER 1.</p>	All

Symptom:**WATER CYCLE VALVE CONTROL SHORTED LOW (ACTIVE)****POSSIBLE CAUSES**

WATER CYCLE VALVE CONTROL CIRCUIT SHORTED TO GROUND

WATER CYCLE VALVE CONTROL CIRCUIT SHORTED TO GROUND CIRCUIT

WATER CYCLE VALVE CONTROL CIRCUIT SHORTED TO SENSOR GROUND CIRCUIT

AUTOMATIC TEMPERATURE CONTROL (ATC)

WATER CYCLE VALVE

TEST	ACTION	APPLICABILITY
1	Turn the ignition off. Disconnect the Water Cycle Valve harness connector. Disconnect the Automatic Temperature Control (ATC) C1 harness connector. Measure the resistance between ground and the Water Cycle Valve Control circuit. Is the resistance below 10k ohms? Yes → Repair the Water Cycle Valve Control circuit for a short to ground. Perform BODY VERIFICATION TEST - VER 1. No → Go To 2	All
2	Turn the ignition off. Disconnect the Water Cycle Valve harness connector. Disconnect the Automatic Temperature Control (ATC) C1 harness connector. Measure the resistance between the Water Cycle Valve Control circuit and the Ground circuit in the Automatic Temperature Control C1 harness connector. Is the resistance below 10k ohms? Yes → Repair the Water Cycle Valve Control circuit for a short to the Ground circuit. Perform BODY VERIFICATION TEST - VER 1. No → Go To 3	All
3	Turn the ignition off. Disconnect the Water Cycle Valve harness connector. Disconnect the Automatic Temperature Control (ATC) C1 harness connector. Measure the resistance between the Water Cycle Valve Control circuit and the Sensor Ground circuit in the Automatic Temperature Control C1 harness connector. Is the resistance below 10k ohms? Yes → Repair the Water Cycle Valve Control circuit for a short to the Sensor Ground circuit. Perform BODY VERIFICATION TEST - VER 1. No → Go To 4	All

WATER CYCLE VALVE CONTROL SHORTED LOW (ACTIVE) — Continued

TEST	ACTION	APPLICABILITY
4	<p>Turn the ignition off.</p> <p>NOTE: Check connectors - Clean/repair as necessary.</p> <p>Reconnect the Automatic Temperature Control (ATC) C1 harness connector.</p> <p>Press the Residual Engine Heat Utilization (REST) switch off.</p> <p>Disconnect the Water Cycle Valve harness connector.</p> <p>Connect a 12-volt test light between the Water Cycle Valve Control circuit and the Ground circuit in the Water Cycle Valve harness connector. The test light should operate as follows:</p> <p>With the Residual Engine Heat Utilization (REST) switch off, the test light should not illuminate.</p> <p>Press the Residual Engine Heat Utilization (REST) switch on.</p> <p>With the Blend control set to Full Cold, the test light should illuminate brightly and continuously.</p> <p>With the Blend control set to one position below the half Cold/Hot setting, the test light should illuminate brightly and blink at a slow continuous rate.</p> <p>With the Blend control set to the half Cold/Hot setting or above, the test light should be off.</p> <p>Does the test light operate as specified?</p> <p style="padding-left: 40px;">Yes → Replace the Water Cycle Valve in accordance with the Service Information. Perform BODY VERIFICATION TEST - VER 1.</p> <p style="padding-left: 40px;">No → Replace the Automatic Temperature Control (ATC) in accordance with the Service Information. Perform BODY VERIFICATION TEST - VER 1.</p>	All

Symptom:

AMBIENT TEMP SENSOR OPEN/SHORT TO BATTERY

POSSIBLE CAUSES
AMBIENT TEMPERATURE SENSOR SIGNAL (+) CIRCUIT SHORT TO VOLTAGE AMBIENT TEMPERATURE SENSOR AMBIENT TEMPERATURE SENSOR SIGNAL RETURN CIRCUIT OPEN AMBIENT TEMPERATURE SENSOR SIGNAL (+) CIRCUIT OPEN INSTRUMENT CLUSTER

TEST	ACTION	APPLICABILITY
1	Turn the ignition off. Disconnect the Ambient Temperature Sensor harness connector. Disconnect the Instrument Cluster C1 harness connector. Measure the voltage between the Ambient Temperature Sensor Signal (+) circuit and ground. Is the voltage above 0.2 volts? Yes → Repair the Ambient Temperature Sensor Signal (+) circuit for a short to voltage. Perform BODY VERIFICATION TEST - VER 1. No → Go To 2	All
2	Disconnect the Ambient Temperature Sensor harness connector. Connect a jumper wire between the Ambient Temperature Sensor Signal (+) and Ambient Temperature Sensor Signal Return circuit. Turn the ignition on, with the DRBIII®, read DTCs. Does the DRBIII® display Ambient Temperature Sensor Short to Ground? Yes → Replace the Ambient Temperature Sensor. Perform BODY VERIFICATION TEST - VER 1. No → Go To 3	All
3	Turn the ignition off. Disconnect the Ambient Temperature Sensor harness connector. Disconnect the Instrument Cluster C1 harness connector. Measure the resistance of the Ambient Temperature Sensor Signal Return circuit between the Instrument Cluster C1 harness connector and the Ambient Temperature Sensor harness connector. Is the resistance above 10 ohms? Yes → Repair the Ambient Temperature Sensor Signal Return circuit for an open. Perform BODY VERIFICATION TEST - VER 1. No → Go To 4	All

INSTRUMENT CLUSTER

AMBIENT TEMP SENSOR OPEN/SHORT TO BATTERY — Continued

TEST	ACTION	APPLICABILITY
4	<p>Turn the ignition off. Disconnect the Instrument Cluster C1 harness connector. Disconnect the Ambient Temperature Sensor harness connector. Measure the resistance of the Ambient Temperature Sensor Signal (+) circuit between the Instrument Cluster C1 harness connector and the Ambient Temperature Sensor harness connector. Is the resistance above 10 ohms?</p> <p>Yes → Repair the Ambient Temperature Sensor Signal (+) circuit for an open. Perform BODY VERIFICATION TEST - VER 1.</p> <p>No → Replace the Instrument Cluster in accordance with the Service Information. Perform BODY VERIFICATION TEST - VER 1.</p>	All

Symptom:

AMBIENT TEMP SENSOR SHORT TO GROUND

POSSIBLE CAUSES
AMBIENT TEMPERATURE SENSOR AMBIENT TEMPERATURE SENSOR SIGNAL (+) CIRCUIT SHORT TO GROUND AMBIENT TEMPERATURE SENSOR SIGNAL (+) CIRCUIT SHORT TO SENSOR RETURN CIRCUIT INSTRUMENT CLUSTER

TEST	ACTION	APPLICABILITY
1	Turn the ignition off. Disconnect the Ambient Temperature Sensor harness connector. Turn the ignition on. With the DRBIII®, read DTCs. Does the DRBIII® display Ambient Temperature Sensor Open/Short to Battery? Yes → Replace the Ambient Temperature Sensor. Perform BODY VERIFICATION TEST - VER 1. No → Go To 2	All
2	Turn the ignition off. Disconnect the Instrument Cluster C1 harness connector. Disconnect the Ambient Temperature Sensor harness connector. Measure the resistance between ground and the Ambient Temperature Sensor Signal (+) circuit. Is the resistance below 1000 ohms? Yes → Repair the Ambient Temperature Sensor Signal (+) circuit for a short to ground. Perform BODY VERIFICATION TEST - VER 1. No → Go To 3	All
3	Turn the ignition off. Disconnect the Ambient Temperature Sensor harness connector. Disconnect the Instrument Cluster C1 harness connector. Measure the resistance between the Ambient Temperature Sensor Signal (+) circuit and Ambient Temperature Sensor Signal Return circuit. Is the resistance below 1000 ohms? Yes → Repair the Ambient Temperature Sensor Signal (+) circuit for a short to the Sensor Return circuit. Perform BODY VERIFICATION TEST - VER 1. No → Replace the Instrument Cluster in accordance with the Service Information. Perform BODY VERIFICATION TEST - VER 1.	All

INSTRUMENT CLUSTER

Symptom:

FUEL LEVEL SENSOR OPEN/SHORT TO BATTERY

POSSIBLE CAUSES

FUEL LEVEL SENSOR
 FUEL LEVEL SENSOR SIGNAL (+) CIRCUIT SHORT TO VOLTAGE
 FUEL LEVEL SENSOR SIGNAL RETURN CIRCUIT OPEN
 FUEL LEVEL SENSOR SIGNAL (+) CIRCUIT OPEN
 INSTRUMENT CLUSTER

TEST	ACTION	APPLICABILITY
1	Turn the ignition off. Disconnect the Fuel Pump Module harness connector. Disconnect the Instrument Cluster C1 harness connector. Turn the ignition on. Measure the voltage between Fuel Level Sensor Signal (+) circuit and ground. Is the voltage above 0.2 volts? Yes → Repair the Fuel Level Sensor Signal (+) circuit for a short to voltage. Perform BODY VERIFICATION TEST - VER 1. No → Go To 2	All
2	Turn the ignition off. Reconnect the Instrument Cluster C1 harness connector. Disconnect the Fuel Pump Module harness connector. Connect a jumper wire between the Fuel Level Sensor Signal (+) and the Fuel Level Sensor Signal Return circuit. Turn the ignition on. With the DRBIII®, read DTCs. Does the DRBIII® display Fuel Level Sensor Open/Short to Battery? Yes → Go To 3 No → Replace the Fuel Level Sensor in accordance with the Service Information. Perform BODY VERIFICATION TEST - VER 1.	All
3	Turn the ignition off. Disconnect the Fuel Pump Module harness connector. Disconnect the Instrument Cluster C1 harness connector. Measure the resistance of the Fuel Level Sensor Signal Return circuit between the Fuel Pump Module harness connector and the Instrument Cluster harness connector. Is the resistance above 10 ohms? Yes → Repair the Fuel Level Sensor Signal Return circuit for an open. Perform BODY VERIFICATION TEST - VER 1. No → Go To 4	All

FUEL LEVEL SENSOR OPEN/SHORT TO BATTERY — Continued

TEST	ACTION	APPLICABILITY
4	<p>Turn the ignition off. Disconnect the Fuel Pump Module harness connector. Disconnect the Instrument Cluster C1 harness connector. Measure the resistance of the Fuel Level Sensor Signal (+) circuit between the Fuel Pump Module harness connector and the Instrument Cluster harness connector. Is the resistance above 10 ohms?</p> <p>Yes → Repair the Fuel Level Sensor Signal (+) circuit for an open. Perform BODY VERIFICATION TEST - VER 1.</p> <p>No → Replace the Instrument Cluster in accordance with the Service Information. Perform BODY VERIFICATION TEST - VER 1.</p>	All

INSTRUMENT CLUSTER

Symptom:

FUEL LEVEL SENSOR SHORT TO GROUND

POSSIBLE CAUSES

FUEL LEVEL SENSOR
 FUEL LEVEL SENSOR CIRCUITS SHORTED TOGETHER
 INSTRUMENT CLUSTER
 FUEL LEVEL SENSOR SIGNAL (+) SHORT TO GROUND

TEST	ACTION	APPLICABILITY
1	Turn the ignition off. Disconnect the Fuel Pump Module harness connector. Turn the ignition on, with the DRBIII®, read DTCs. Does the DRBIII® display: Fuel Level Sensor Shorted to Ground? Yes → Go To 2 No → Replace the Fuel Level Sensor in accordance with the Service Information. Perform BODY VERIFICATION TEST - VER 1.	All
2	Turn the ignition off. Disconnect the Instrument Cluster C1 harness connector. Disconnect the Fuel Pump Module harness connector. Measure the resistance between ground and the Fuel Level Sensor Signal (+) circuit. Is the resistance below 1000 ohms? Yes → Repair the Fuel Level Sensor Signal (+) circuit for a short to ground. Perform BODY VERIFICATION TEST - VER 1. No → Go To 3	All
3	Turn the ignition off. Disconnect the Fuel Pump Module harness connector. Disconnect the Instrument Cluster C1 harness connector. Measure the resistance between the Fuel Level Sensor Signal (+) circuit and Fuel Level Sensor Signal Return circuit. Is the resistance below 1000 ohms? Yes → Repair the Fuel Level Sensor Signal (+) circuit for a short to the Sensor Return circuit. Perform BODY VERIFICATION TEST - VER 1. No → Replace the Instrument Cluster in accordance with the Service Information. Perform BODY VERIFICATION TEST - VER 1.	All

Symptom:

INSTRUMENT CLUSTER INTERNAL FAILURE B1043

POSSIBLE CAUSES
CAN BUS FAILURE INSTRUMENT CLUSTER

TEST	ACTION	APPLICABILITY
1	<p>If this fault is present, scan the Engine Control Module and/or Transmission Control Module for any CAN Bus related faults. Are any CAN Bus Related faults present?</p> <p style="padding-left: 40px;">Yes → Refer to the symptom list for repair information relating to CAN Bus failures. Perform BODY VERIFICATION TEST - VER 1.</p> <p style="padding-left: 40px;">No → Go To 2</p>	All
2	<p>With the DRBIII®, erase DTCs. Turn the ignition off, wait 10 seconds, then turn the ignition on. With the DRBIII®, read DTCs. Does the DRBIII® read: B1043 Instrument Cluster Internal Failure?</p> <p style="padding-left: 40px;">View Repair Replace the Instrument Cluster in accordance with the Service Information. Perform BODY VERIFICATION TEST - VER 1.</p>	All

INSTRUMENT CLUSTER

Symptom:

INSTRUMENT CLUSTER INTERNAL FAILURE B1053

POSSIBLE CAUSES

CAN BUS FAILURE
INSTRUMENT CLUSTER

TEST	ACTION	APPLICABILITY
1	<p>If this fault is present, scan the Engine Control Module and/or Transmission Control Module for any CAN Bus related faults. Are any CAN Bus Related faults present?</p> <p>Yes → Refer to the symptom list for repair information relating to CAN Bus failures. Perform BODY VERIFICATION TEST - VER 1.</p> <p>No → Go To 2</p>	All
2	<p>With the DRBIII®, erase DTCs. Turn the ignition off, wait 10 seconds, then turn the ignition on. With the DRBIII®, read DTCs. Does the DRBIII® read: B1053 Instrument Cluster Internal Failure?</p> <p>View Repair Replace the Instrument Cluster in accordance with the Service Information. Perform BODY VERIFICATION TEST - VER 1.</p>	All

Symptom:
INSTRUMENT CLUSTER OVERVOLTAGE

POSSIBLE CAUSES
CHARGING SYSTEM OVERCHARGE INSTRUMENT CLUSTER

TEST	ACTION	APPLICABILITY
1	Check the Charging System for proper operation in accordance with the Service Information. Is the Charging system operating properly? Yes → Replace the Instrument Cluster in accordance with the service information. Perform BODY VERIFICATION TEST - VER 1. No → Repair the vehicle's charging system in accordance with the Service Information. Perform BODY VERIFICATION TEST - VER 1.	All

INSTRUMENT CLUSTER

Symptom:

NO CAN COMMUNICATION WITH ABS

POSSIBLE CAUSES

DTC PRESENT
 OPEN CAN CIRCUITS AT INSTRUMENT CLUSTER
 INSTRUMENT CLUSTER
 CHECK POWERS AND GROUNDS TO THE AFFECTED MODULE
 OPEN CAN CIRCUITS AT CAB
 CONTROLLER ANTILOCK BRAKE

TEST	ACTION	APPLICABILITY
1	<p>With the DRBIII®, record and erase DTC's. Cycle the ignition switch from ON to OFF to ON. With the DRBIII®, read DTC's. Did this DTC reset?</p> <p>Yes → Go To 2</p> <p>No → The conditions that caused this code to set are not present at this time. Using the wiring diagram/schematic as a guide, inspect the wiring and connectors for an intermittent condition. Perform BODY VERIFICATION TEST - VER 1.</p>	All
2	<p>With the DRBIII®, check the TCM, ECM, and the Shifter Assembly for this same or similar ABS message error DTC. Is the same or similar DTC set in the other modules?</p> <p>Yes → Go To 3</p> <p>No → Go To 5</p>	All
3	<p>Turn the ignition off. Disconnect the Controller Antilock Brake harness connector. Check each power and ground circuit to the module. Were any problems found?</p> <p>Yes → Refer to the wiring diagrams located in the service information to help isolate an open or shorted condition. Repair as necessary. Perform BODY VERIFICATION TEST - VER 1.</p> <p>No → Go To 4</p>	All
4	<p>Turn the ignition off to the lock position. Disconnect the Controller Antilock Brake harness connector. Measure the resistance between the CAN C Bus (+) circuit and the CAN C Bus (-) circuit in the CAB harness connector. Is the resistance 60 ohms, ± 3.0 ohms?</p> <p>Yes → Replace the Controller Antilock Brake in accordance with the service information. Perform BODY VERIFICATION TEST - VER 1.</p> <p>No → Repair the CAN C Bus (+) or the CAN C Bus (-) circuit for an open. Perform BODY VERIFICATION TEST - VER 1.</p>	All

NO CAN COMMUNICATION WITH ABS — Continued

TEST	ACTION	APPLICABILITY
5	<p>Turn the ignition off to the lock position. Disconnect the Instrument Cluster C1 harness connector. Measure the resistance between the CAN C Bus (+) circuit and the CAN C Bus (-) circuit in the Instrument Cluster harness connector. Is the resistance 60 ohms, \pm 3.0 ohms?</p> <p>Yes → Replace the Instrument Cluster in accordance with the service information. Perform BODY VERIFICATION TEST - VER 1.</p> <p>No → Repair the CAN C Bus (+) or the CAN C Bus (-) circuit for an open. Perform BODY VERIFICATION TEST - VER 1.</p>	All

INSTRUMENT CLUSTER

Symptom:

NO CAN COMMUNICATION WITH ECM

POSSIBLE CAUSES

DTC PRESENT
 OPEN CAN CIRCUITS AT INSTRUMENT CLUSTER
 INSTRUMENT CLUSTER
 CHECK POWERS AND GROUNDS TO THE AFFECTED MODULE
 OPEN CAN CIRCUITS AT ECM
 ECM

TEST	ACTION	APPLICABILITY
1	<p>With the DRBIII®, record and erase DTC's. Cycle the ignition switch from ON to OFF to ON. With the DRBIII®, read DTC's. Did this DTC reset?</p> <p>Yes → Go To 2</p> <p>No → The conditions that caused this code to set are not present at this time. Using the wiring diagram/schematic as a guide, inspect the wiring and connectors for an intermittent condition. Perform BODY VERIFICATION TEST - VER 1.</p>	All
2	<p>With the DRBIII®, check the TCM, ABS, and the ATC Module for this same or similar ECM message error DTC. Is the same or similar DTC set in the other modules?</p> <p>Yes → Go To 3</p> <p>No → Go To 5</p>	All
3	<p>Turn the ignition off. Disconnect the ECM harness connector. Check each power and ground circuit to the module. Were any problems found?</p> <p>Yes → Refer to the wiring diagrams located in the service information to help isolate an open or shorted condition. Repair as necessary. Perform BODY VERIFICATION TEST - VER 1.</p> <p>No → Go To 4</p>	All
4	<p>Turn the ignition off to the lock position. Disconnect the ECM harness connector. Measure the resistance between the CAN C Bus (+) circuit and the CAN C Bus (-) circuit in the ECM harness connector. Is the resistance 120 ohms, ± 3.0 ohms?</p> <p>Yes → Replace the ECM in accordance with the service information. Perform BODY VERIFICATION TEST - VER 1.</p> <p>No → Repair the CAN C Bus (+) or the CAN C Bus (-) circuit for an open. Perform BODY VERIFICATION TEST - VER 1.</p>	All

NO CAN COMMUNICATION WITH ECM — Continued

TEST	ACTION	APPLICABILITY
5	<p>Turn the ignition off to the lock position. Disconnect the Instrument Cluster C1 harness connector. Reconnect the ECM harness connector. Measure the resistance between the CAN C Bus (+) circuit and the CAN C Bus (-) circuit in the Instrument Cluster harness connector. Is the resistance 60 ohms, \pm 3.0 ohms?</p> <p>Yes → Replace the Instrument Cluster in accordance with the service information. Perform BODY VERIFICATION TEST - VER 1.</p> <p>No → Repair the CAN C Bus (+) or the CAN C Bus (-) circuit for an open. Perform BODY VERIFICATION TEST - VER 1.</p>	All

INSTRUMENT CLUSTER

Symptom:

NO CAN COMMUNICATION WITH TCM

POSSIBLE CAUSES

DTC PRESENT
 OPEN CAN CIRCUITS AT INSTRUMENT CLUSTER
 INSTRUMENT CLUSTER
 CHECK POWERS AND GROUNDS TO THE AFFECTED MODULE
 OPEN CAN CIRCUITS AT TCM
 TCM

TEST	ACTION	APPLICABILITY
1	<p>With the DRBIII®, record and erase DTC's. Cycle the ignition switch from ON to OFF to ON. With the DRBIII®, read DTC's. Did this DTC reset?</p> <p>Yes → Go To 2</p> <p>No → The conditions that caused this code to set are not present at this time. Using the wiring diagram/schematic as a guide, inspect the wiring and connectors for an intermittent condition. Perform BODY VERIFICATION TEST - VER 1.</p>	All
2	<p>With the DRBIII®, check the ABS, ECM for this same or similar TCM message error DTC. Is the same or similar DTC set in the ECM?</p> <p>Yes → Go To 3</p> <p>No → Go To 5</p>	All
3	<p>Turn the ignition off. Disconnect the TCM harness connector. Check each power and ground circuit to the module. Were any problems found?</p> <p>Yes → Refer to the wiring diagrams located in the service information to help isolate an open or shorted condition. Repair as necessary. Perform BODY VERIFICATION TEST - VER 1.</p> <p>No → Go To 4</p>	All
4	<p>Turn the ignition off to the lock position. Disconnect the TCM harness connector. Measure the resistance between the CAN C Bus (+) circuit and the CAN C Bus (-) circuit in the TCM harness connector. Is the resistance 60 ohms, ± 3.0 ohms?</p> <p>Yes → Replace the TCM in accordance with the service information. Perform BODY VERIFICATION TEST - VER 1.</p> <p>No → Repair the CAN C Bus (+) or the CAN C Bus (-) circuit for an open. Perform BODY VERIFICATION TEST - VER 1.</p>	All

NO CAN COMMUNICATION WITH TCM — Continued

TEST	ACTION	APPLICABILITY
5	<p>Turn the ignition off to the lock position. Disconnect the Instrument Cluster C1 harness connector. Measure the resistance between the CAN C Bus (+) circuit and the CAN C Bus (-) circuit in the Instrument Cluster harness connector. Is the resistance 60 ohms, \pm 3.0 ohms?</p> <p>Yes → Replace the Instrument Cluster in accordance with the service information. Perform BODY VERIFICATION TEST - VER 1.</p> <p>No → Repair the CAN C Bus (+) or the CAN C Bus (-) circuit for an open. Perform BODY VERIFICATION TEST - VER 1.</p>	All

INSTRUMENT CLUSTER

Symptom:

PREGLOW INDICATOR LAMP FAILURE

POSSIBLE CAUSES

INSTRUMENT CLUSTER

TEST	ACTION	APPLICABILITY
1	<p>NOTE: The Instrument Cluster performs internal tests on the indicators during each ignition cycle.</p> <p>With the DRBIII®, erase DTCs. Turn the ignition off, wait 10 seconds, then turn the ignition on. With the DRBIII®, read DTCs. Does the DRBIII® read: Preglow Indicator Lamp Failure?</p> <p>Yes → Replace the Instrument Cluster in accordance with the Service Information. Perform BODY VERIFICATION TEST - VER 1.</p> <p>No → Test Complete.</p>	All

Symptom:
SRS INDICATOR LAMP FAILURE

POSSIBLE CAUSES

INSTRUMENT CLUSTER

TEST	ACTION	APPLICABILITY
1	<p>If this fault is present, interrogate the Airbag Control Module for any SRS Indicator faults.</p> <p>NOTE: The Instrument Cluster performs internal tests on the indicators during each ignition cycle.</p> <p>With the DRBIII®, erase DTCs.</p> <p>Turn the ignition off, wait 10 seconds, then turn the ignition on.</p> <p>With the DRBIII®, read DTCs.</p> <p>Does the DRBIII® read: SRS Indicator Lamp Failure?</p> <p>Yes → Replace the Instrument Cluster in accordance with the Service Information. Perform BODY VERIFICATION TEST - VER 1.</p> <p>No → Test Complete.</p>	All

Symptom:

DRIVER DOOR AJAR INDICATOR DRIVER CIRCUIT SHORT TO GROUND

When Monitored and Set Condition:

DRIVER DOOR AJAR INDICATOR DRIVER CIRCUIT SHORT TO GROUND

When Monitored: Whenever the battery is above 10.0 volts and the module is connected.

Set Condition: Whenever the CTM senses resistance on the Driver Door Ajar Indicator Driver circuit for over 30 seconds, this code will set.

POSSIBLE CAUSES
DTC PRESENT
MASTER DOOR LOCK SWITCH SHORTED
CENTRAL TIMER MODULE SHORTED
DRIVER DOOR AJAR INDICATOR DRIVER WIRE SHORT TO GROUND

TEST	ACTION	APPLICABILITY
1	With the DRBIII®, record and erase DTC's. Cycle the ignition switch from ON to OFF to ON. With the DRBIII®, read DTC's. Operate the Door Locks several times while observing the DRBIII®. Wait 10 seconds. Does the DRBIII® display DRIVER DOOR AJAR INDICATOR CIRCUIT SHORT TO GROUND? Yes → Go To 2 No → The conditions that caused this code to set are not present at this time. Using the wiring diagram/schematic as a guide, inspect the wiring and connectors for an intermittent condition. Perform BODY VERIFICATION TEST - VER 1.	All
2	Turn the ignition off. Disconnect the Master Door Lock Switch connector. Measure the resistance between ground and the Driver Door Ajar Indicator Driver circuit. Is the resistance below 1000.0 ohms? Yes → Go To 3 No → Replace the Master Door Lock Switch. Perform BODY VERIFICATION TEST - VER 1.	All

DRIVER DOOR AJAR INDICATOR DRIVER CIRCUIT SHORT TO GROUND — Continued

TEST	ACTION	APPLICABILITY
3	Disconnect the Central Timer Module C1 connector. Disconnect the Master Door Lock Switch connector. Measure the resistance between ground and the Driver Door Ajar Indicator Driver circuit. Is the resistance below 20000.0 ohms? Yes → Repair the Driver Door Ajar Indicator Driver wire for a short to ground. Perform BODY VERIFICATION TEST - VER 1. No → Replace the Central Timer Module. Perform BODY VERIFICATION TEST - VER 1.	All

Symptom:

PASSENGER DOOR AJAR INDICATOR DRIVER CIRCUIT SHORT TO GROUND

When Monitored and Set Condition:

PASSENGER DOOR AJAR INDICATOR DRIVER CIRCUIT SHORT TO GROUND

When Monitored: Whenever the battery is above 10.0 volts and the module is connected.

Set Condition: Whenever the CTM senses resistance on the Passenger Door Ajar Indicator Driver circuit for over 30 seconds, this code will set.

POSSIBLE CAUSES

DTC PRESENT

MASTER DOOR LOCK SWITCH SHORTED

CENTRAL TIMER MODULE SHORTED

PASSENGER DOOR AJAR INDICATOR DRIVER WIRE SHORT TO GROUND

TEST	ACTION	APPLICABILITY
1	With the DRBIII®, record and erase DTC's. Cycle the ignition switch from ON to OFF to ON. With the DRBIII®, read DTC's. Operate the Door Locks several times while observing the DRBIII®. Wait 10 seconds. Does the DRBIII® display PASSENGER DOOR AJAR INDICATOR CIRCUIT SHORT TO GROUND? Yes → Go To 2 No → The conditions that caused this code to set are not present at this time. Using the wiring diagram/schematic as a guide, inspect the wiring and connectors for an intermittent condition. Perform BODY VERIFICATION TEST - VER 1.	All
2	Turn the ignition off. Disconnect the Master Door Lock Switch connector. Measure the resistance between ground and the Passenger Door Ajar Indicator Driver circuit.. Is the resistance below 1000.0 ohms? Yes → Go To 3 No → Replace the Master Door Lock Switch. Perform BODY VERIFICATION TEST - VER 1.	All

PASSENGER DOOR AJAR INDICATOR DRIVER CIRCUIT SHORT TO GROUND — Continued

TEST	ACTION	APPLICABILITY
3	Disconnect the Central Timer Module C1 connector. Disconnect the Master Door Lock Switch connector. Measure the resistance between ground and the Passenger Door Ajar Indicator Driver circuit. Is the resistance below 20000.0 ohms? Yes → Repair the Passenger Door Ajar Indicator Driver wire for a short to ground. Perform BODY VERIFICATION TEST - VER 1. No → Replace the Central Timer Module. Perform BODY VERIFICATION TEST - VER 1.	All

Symptom:

REPLACE CONTROL MODULE

When Monitored and Set Condition:

REPLACE CONTROL MODULE

When Monitored: Whenever the battery voltage is above 10.0 volts and the module is connected.

Set Condition: The SKREEM has detected an internal failure and must be replaced.

POSSIBLE CAUSES

CTM INTERNAL FAILURE

TEST	ACTION	APPLICABILITY
1	View repair. Repair Replace the Sentry Key RemotE Entry Module in accordance with Service Instructions. Perform BODY VERIFICATION TEST - VER 1.	All

Symptom:**RKE INTERFACE CIRCUIT SHORT TO GROUND - CTM****When Monitored and Set Condition:****RKE INTERFACE CIRCUIT SHORT TO GROUND - CTM**

When Monitored: Whenever the battery voltage is above 10.0 volts and the module is connected.

Set Condition: If the CTM monitors a resistance below 7500.0 ohms for over 1 minute, this code will set.

POSSIBLE CAUSES

DTC PRESENT
CENTRAL TIMER MODULE SHORTED
RKE INTERFACE WIRE SHORTED
SKREEM SHORTED

TEST	ACTION	APPLICABILITY
1	With the DRBIII®, record and erase DTC's. Cycle the ignition switch from ON to OFF to ON. With the DRBIII®, read DTC's. Using the RKE transmitter, operate the Door Locks several times while observing the DRBIII®. Wait 10 seconds. Does the DRBIII® display RKE INTERFACE CIRCUIT SHORT TO GROUND? Yes → Go To 2 No → Using the wiring diagram/schematic as a guide, inspect the wiring and connectors for an intermittent condition. Using the RKE transmitter, operate the door locks several times and re-check for any DTC's. Perform BODY VERIFICATION TEST - VER 1.	All
2	Turn the ignition off. Disconnect the Central Timer Module C1 connector. Measure the resistance between ground and the RKE Interface circuit. Is the resistance below 8500.0 ohms? Yes → Go To 3 No → Replace the Central Timer Module. Perform BODY VERIFICATION TEST - VER 1.	All

RKE INTERFACE CIRCUIT SHORT TO GROUND - CTM — Continued

TEST	ACTION	APPLICABILITY
3	Disconnect the Central Timer Module C1 connector. Disconnect the SKREEM connector. Measure the resistance between ground and the RKE Interface circuit. Is the resistance below 20000.0 ohms? Yes → Repair the RKE Interface circuit for a short to ground. Perform BODY VERIFICATION TEST - VER 1. No → Replace the Sentry Key RemotE Entry Module. Perform BODY VERIFICATION TEST - VER 1.	All

Symptom:**RKE INTERFACE CIRCUIT SHORT TO GROUND - SKREEM****When Monitored and Set Condition:****RKE INTERFACE CIRCUIT SHORT TO GROUND - SKREEM**

When Monitored: Whenever the battery voltage is above 10.0 volts and the module is connected.

Set Condition: If the SKREEM monitors a resistance below 4000.0 ohms or over 9000.0 ohms for over 30 seconds, this code will set.

POSSIBLE CAUSES

DTC PRESENT
 SENTRY KEY REMOTE ENTRY MODULE SHORTED
 RKE INTERFACE WIRE SHORTED
 RKE INTERFACE WIRE OPEN
 CENTRAL TIMER MODULE FAILURE

TEST	ACTION	APPLICABILITY
1	With the DRBIII®, record and erase DTC's. Cycle the ignition switch from ON to OFF to ON. With the DRBIII®, read DTC's. Using the RKE transmitter, operate the Door Locks several times while observing the DRBIII®. Wait 10 seconds. Does the DRBIII® display RKE INTERFACE CIRCUIT OPEN OR SHORT TO GROUND? Yes → Go To 2 No → Using the wiring diagram/schematic as a guide, inspect the wiring and connectors for an intermittent condition. Using the RKE transmitter, operate the door locks several times and re-check for any DTC's. Perform BODY VERIFICATION TEST - VER 1.	All
2	Turn the ignition off. Disconnect the Sentry Key RemotE Entry Module connector. Measure the resistance between ground and the RKE Interface circuit. Is the resistance between 5500.0 (5.5K) and 6500.0 (6.5K) ohms? Yes → Replace the Sentry Key Remote Entry Module. Perform BODY VERIFICATION TEST - VER 1. No → Go To 3	All

RKE INTERFACE CIRCUIT SHORT TO GROUND - SKREEM — Continued

TEST	ACTION	APPLICABILITY
3	Disconnect the Central Timer Module C1 connector. Disconnect the SKREEM connector. Measure the resistance between ground and the RKE Interface circuit. Is the resistance below 20000.0 ohms? Yes → Repair the RKE Interface circuit for a short to ground. Perform BODY VERIFICATION TEST - VER 1. No → Go To 4	All
4	Disconnect the Central Timer Module C1 connector. Disconnect the SKREEM connector. Measure the resistance of the RKE Interface circuit between the SKREEM connector and the CTM C1 connector. Is the resistance below 5.0 ohms? Yes → Replace the Central Timer Module. Perform BODY VERIFICATION TEST - VER 1. No → Repair the RKE Interface circuit for an open. Perform BODY VERIFICATION TEST - VER 1.	All

Symptom:**RKE INTERFACE CIRCUIT SHORT TO VOLTAGE - CTM****When Monitored and Set Condition:****RKE INTERFACE CIRCUIT SHORT TO VOLTAGE - CTM**

When Monitored: Whenever the battery voltage is above 10.0 volts and the module is connected.

Set Condition: If the CTM monitors a voltage on the RKE Interface circuit for over 30 seconds, this code will set.

POSSIBLE CAUSES

CENTRAL TIMER MODULE SHORT TO VOLTAGE

RKE INTERFACE WIRE SHORT TO VOLTAGE

SKREEM SHORTED

TEST	ACTION	APPLICABILITY
1	Turn the ignition off. Disconnect the Central Timer Module C1 connector. Measure the voltage between ground and the RKE Interface circuit. Is there any voltage present? Yes → Go To 2 No → Replace the Central Timer Module. Perform BODY VERIFICATION TEST - VER 1.	All
2	Disconnect the Central Timer Module C1 connector. Disconnect the SKREEM connector. Turn the ignition on. Measure the voltage between ground and the RKE Interface circuit. Is there any voltage present? Yes → Repair the RKE Interface circuit for a short to voltage. Perform BODY VERIFICATION TEST - VER 1. No → Replace the Sentry Key RemotE Entry Module. Perform BODY VERIFICATION TEST - VER 1.	All

Symptom:

RKE INTERFACE CIRCUIT SHORT TO VOLTAGE - SKREEM

When Monitored and Set Condition:

RKE INTERFACE CIRCUIT SHORT TO VOLTAGE - SKREEM

When Monitored: Whenever the battery voltage is above 10.0 volts and the module is connected.

Set Condition: If the SKREEM monitors a voltage on the RKE Interface circuit for over 30 seconds, this code will set.

POSSIBLE CAUSES

DTC PRESENT
 SENTRY KEY REMOTE ENTRY MODULE SHORT TO VOLTAGE
 RKE INTERFACE WIRE SHORT TO VOLTAGE
 CENTRAL TIMER MODULE SHORTED

TEST	ACTION	APPLICABILITY
1	With the DRBIII®, record and erase DTC's. Cycle the ignition switch from ON to OFF to ON. With the DRBIII®, read DTC's. Turn the ignition off and remove the key. Using the RKE transmitter, operate the Door Locks several times while observing the DRBIII®. Wait 10 seconds. Does the DRBIII® display RKE INTERFACE CIRCUIT SHORT TO VOLTAGE? Yes → Go To 2 No → Using the wiring diagram/schematic as a guide, inspect the wiring and connectors for an intermittent condition. Using the RKE transmitter, operate the door locks several times and re-check for any DTC's. Perform BODY VERIFICATION TEST - VER 1.	All
2	Turn the ignition off. Disconnect the Sentry Key Remote Entry Module connector. Measure the voltage between ground and the RKE Interface circuit. Is there any voltage present? Yes → Go To 3 No → Replace the Sentry Key Remote Entry Module. Perform BODY VERIFICATION TEST - VER 1.	All

RKE INTERFACE CIRCUIT SHORT TO VOLTAGE - SKREEM — Continued

TEST	ACTION	APPLICABILITY
3	Disconnect the Central Timer Module C1 connector. Disconnect the SKREEM connector. Turn the ignition on. Measure the voltage between ground and the RKE Interface circuit. Is there any voltage present? Yes → Repair the RKE Interface circuit for a short to voltage. Perform BODY VERIFICATION TEST - VER 1. No → Replace the Central Timer Module. Perform BODY VERIFICATION TEST - VER 1.	All

Symptom:

THE ACM HAS UNLOCKED THE DOORS

When Monitored and Set Condition:

THE ACM HAS UNLOCKED THE DOORS

When Monitored: Whenever the battery is above 10.0 volts and the module is connected.

Set Condition: Whenever the CTM senses battery voltage for over 50ms on the Enhanced Accident Report Driver circuit, this code will set. If the ACM senses a near deployment impact (not enough to fire the airbag) this code may set.

POSSIBLE CAUSES

DTC PRESENT
POWERTRAIN DTC

TEST	ACTION	APPLICABILITY
1	With the DRBIII®, record and erase DTC's. Cycle the ignition switch from ON to OFF to ON. With the DRBIII®, read DTC's. Operate the Door Locks several times while observing the DRBIII®. Wait 10 seconds. Does the DRBIII® display THE ACM HAS UNLOCKED THE DOORS? Yes → Refer to symptom P1681 ACM CIRCUIT FAULT in the POWER-TRAIN SERVICE INFORMATION. Perform BODY VERIFICATION TEST - VER 1. No → The condition that set this code is not present at this time. By erasing the DTC the door locks should work properly at this time. Perform BODY VERIFICATION TEST - VER 1.	All

Symptom:**UNKNOWN TROUBLE CODE UNKNOWN DTC TYPE 2****When Monitored and Set Condition:****UNKNOWN TROUBLE CODE UNKNOWN DTC TYPE 2**

When Monitored: Whenever the battery voltage is above 10.0 volts and the module is connected.

Set Condition: The SKREEM has detected a code but is confused as to which one it is.

POSSIBLE CAUSES

DTC PRESENT
SKREEM SHORTED

TEST	ACTION	APPLICABILITY
1	With the DRBIII®, record and erase DTC's. Cycle the ignition switch from ON to OFF to ON. With the DRBIII®, read DTC's. Turn the ignition off and remove the key. Using the RKE transmitter, operate the Door Locks several times while observing the DRBIII®. Wait 10 seconds. Does the DRBIII® display UNKNOWN TROUBLE CODE UNKNOWN TYPE 2? Yes → Replace the Sentry Key RemotE Entry Module. Perform BODY VERIFICATION TEST - VER 1. No → The conditions that caused this code to set are not present at this time. Using the RKE transmitter, operate the door locks several times and re-check for any DTC's. Perform BODY VERIFICATION TEST - VER 1.	All

POWER DOOR LOCKS/RKE

Symptom:

***RKE INOPERATIVE**

POSSIBLE CAUSES

DTC PRESENT
 TRANSMITTER INOPERATIVE
 CENTRAL TIMER MODULE
 SKREEM OPEN

TEST	ACTION	APPLICABILITY
1	With the DRBIII®, read DTC's. Turn the ignition off and remove the key. Using the RKE transmitter, operate the Door Locks several times while observing the DRBIII®. Wait 10 seconds. Does the DRBIII® display any Door Lock or RKE related DTC's? Yes → Refer to symptom list for problems related to POWER DOOR LOCKS/RKE.. Perform BODY VERIFICATION TEST - VER 1. No → Go To 2	All
2	Ensure the batteries in the transmitter are good before proceeding. Using the Miller Tool 9001 RF DETECTOR, test the transmitter. Does the transmitter pass the test? Yes → Go To 3 No → Replace and program the RKE Transmitter. Perform BODY VERIFICATION TEST - VER 1.	All
3	NOTE: If only one of the transmitters used with this vehicle is inoperative, follow the instructions in the General Information section to put it back in synchronization before proceeding. Turn the ignition off. Disconnect the Central Timer Module C1 connector. Measure the resistance between ground and the RKE Interface circuit. While observing the ohmmeter, press any button on the RKE transmitter. NOTE: The resistance will be approximately 9000.0 ohms coming from the SKREEM module. Did the meter go to OL when the button was pressed? Yes → Replace the Central Timer Module. Perform BODY VERIFICATION TEST - VER 1. No → Replace the Sentry Key RemotE Entry Module. Perform BODY VERIFICATION TEST - VER 1.	All

Symptom:***RKE POOR RANGE****POSSIBLE CAUSES**

DTC PRESENT
 ANTENNA OPEN OR SHORTED
 SKREEM OPEN

TEST	ACTION	APPLICABILITY
1	With the DRBIII®, read DTC's. Turn the ignition off and remove the key. Using the RKE transmitter, operate the Door Locks several times while observing the DRBIII®. Wait 10 seconds. Does the DRBIII® display any Door Lock or RKE related DTC's? Yes → Refer to symptom list for problems related to POWER DOOR LOCKS/RKE.. Perform BODY VERIFICATION TEST - VER 1. No → Go To 2	All
2	Gain access to and disconnect the SKREEM module connector. Measure the resistance between ground and the RKE Antenna circuit. NOTE: The resistance should be between 0.2 and 0.4 ohms. Is the resistance between 0.2 and 0.4 ohms? Yes → Replace the Sentry Key RemotE Entry Module. Perform BODY VERIFICATION TEST - VER 1. No → Replace the RKE Antenna in the left A-pillar Perform BODY VERIFICATION TEST - VER 1.	All

Symptom:

DRIVER CYLINDER LOCK SWITCH CIRCUIT SHORT TO GROUND

When Monitored and Set Condition:

DRIVER CYLINDER LOCK SWITCH CIRCUIT SHORT TO GROUND

When Monitored: Whenever the battery voltage is above 10.0 volts and the Security System Module is connected.

Set Condition: If the Driver Cylinder Lock Sense circuit is grounded for over 30 seconds, this code will set.

POSSIBLE CAUSES

DTC PRESENT

DRIVER CYLINDER LOCK SWITCH SHORTED

DRIVER CYLINDER LOCK SENSE CIRCUIT SHORT TO GROUND

SECURITY SYSTEM MODULE SHORT TO GROUND

TEST	ACTION	APPLICABILITY
1	<p>With the DRBIII®, record and erase DTC's. Cycle the ignition switch from ON to OFF to ON. With the DRBIII®, read DTC's. Remove the ignition key. Lock and unlock the doors from the Driver Cylinder Lock Switch several times while observing the DRBIII®. Wait 10 seconds. Does the DRBIII® display DRIVER CYLINDER LOCK SWITCH CIRCUIT SHORT TO GROUND?</p> <p>Yes → Go To 2</p> <p>No → The conditions that caused this code to set are not present at this time. Using the wiring diagram/schematic as a guide, inspect the wiring and connectors for an intermittent condition. Perform BODY VERIFICATION TEST - VER 1.</p>	All
2	<p>Turn the ignition off. Disconnect the Driver Cylinder Lock Switch connector. Measure the resistance between ground and the Driver Cylinder Lock Sense circuit. Is the resistance below 400.0 ohms?</p> <p>No → Replace the Driver Cylinder Lock Switch. Perform BODY VERIFICATION TEST - VER 1.</p> <p>Yes → Go To 3</p>	All

**DRIVER CYLINDER LOCK SWITCH CIRCUIT SHORT TO GROUND —
Continued**

TEST	ACTION	APPLICABILITY
3	<p>Turn the ignition off. Disconnect the Driver Cylinder Lock Switch connector. Disconnect the Security System Module. Measure the resistance between ground and the Driver Cylinder Lock Sense circuit. Is the resistance below 400.0 ohms?</p> <p>Yes → Repair the Driver Cylinder Lock Sense circuit for a short to ground. Perform BODY VERIFICATION TEST - VER 1.</p> <p>No → Replace the Security System Module. Perform BODY VERIFICATION TEST - VER 1.</p>	All

Symptom:

DRIVER CYLINDER UNLOCK SWITCH CIRCUIT SHORT TO GROUND

When Monitored and Set Condition:

DRIVER CYLINDER UNLOCK SWITCH CIRCUIT SHORT TO GROUND

When Monitored: Whenever the battery voltage is above 10.0 volts and the Security System Module is connected.

Set Condition: If the Driver Cylinder Unlock Circuit is closed to ground for over 30 seconds, this code will set.

POSSIBLE CAUSES

DTC PRESENT

DRIVER CYLINDER LOCK SWITCH SHORTED

DRIVER CYLINDER UNLOCK SENSE CIRCUIT SHORT TO GROUND

SECURITY SYSTEM MODULE SHORT TO GROUND

TEST	ACTION	APPLICABILITY
1	<p>With the DRBIII®, record and erase DTC's. Cycle the ignition switch from ON to OFF to ON. With the DRBIII®, read DTC's. Lock and unlock the doors from the Driver Cylinder Lock Switch several times while observing the DRBIII®. Wait 10 seconds. Does the DRBIII® display DRIVER CYLINDER UNLOCK SWITCH CIRCUIT SHORT TO GROUND?</p> <p>Yes → Go To 2</p> <p>No → The conditions that caused this code to set are not present at this time. Using the wiring diagram/schematic as a guide, inspect the wiring and connectors for an intermittent condition. Perform BODY VERIFICATION TEST - VER 1.</p>	All
2	<p>Turn the ignition off. Disconnect the Driver Cylinder Lock Switch connector. Measure the resistance between ground and the Driver Cylinder Unlock Sense circuit. Is the resistance below 400.0 ohms?</p> <p>No → Replace the Driver Cylinder Lock Switch. Perform BODY VERIFICATION TEST - VER 1.</p> <p>Yes → Go To 3</p>	All

**DRIVER CYLINDER UNLOCK SWITCH CIRCUIT SHORT TO GROUND —
Continued**

TEST	ACTION	APPLICABILITY
3	<p>Turn the ignition off. Disconnect the Driver Cylinder Lock Switch connector. Disconnect the Security System Module. Measure the resistance between ground and the Driver Cylinder Unlock Sense circuit. Is the resistance below 400.0 ohms?</p> <p>Yes → Repair the Driver Cylinder Unlock Sense circuit for a short to ground. Perform BODY VERIFICATION TEST - VER 1.</p> <p>No → Replace the Security System Module. Perform BODY VERIFICATION TEST - VER 1.</p>	All

Symptom:

FRONT DOOR JAMB SWITCH CIRCUIT SHORT TO GROUND

When Monitored and Set Condition:

FRONT DOOR JAMB SWITCH CIRCUIT SHORT TO GROUND

When Monitored: Whenever the battery voltage is above 10.0 volts and the Security System Module is connected.

Set Condition: If a front door jamb switch is closed or the front courtesy lamps control circuit is grounded for over 30 minutes, this code will set.

POSSIBLE CAUSES

DTC PRESENT
 DRIVER DOOR JAMB SWITCH SHORTED
 PASSENGER DOOR JAMB SWITCH SHORTED
 SECURITY SYSTEM MODULE SHORTED
 FRONT COURTESY LAMPS CONTROL SHORT TO GROUND

TEST	ACTION	APPLICABILITY
1	<p>NOTE: Ensure the front courtesy lamp switches are operating properly before proceeding. NOTE: If this code is active, the front courtesy lamps will remain on with all the doors closed.</p> <p>With the DRBIII®, record and erase DTC's. Cycle the ignition switch from ON to OFF to ON. With the DRBIII®, read DTC's. Open and close the front doors several times while observing the DRBIII®. Wait 10 seconds. Does the DRBIII® display FRONT DOOR JAMB SWITCH CIRCUIT SHORT TO GROUND?</p> <p>Yes → Go To 2</p> <p>No → The conditions that caused this code to set are not present at this time. Using the wiring diagram/schematic as a guide, inspect the wiring and connectors for an intermittent condition. Perform BODY VERIFICATION TEST - VER 1.</p>	All
2	<p>Turn the ignition off. Disconnect the Driver Door Jamb Switch connector. Ensure the passenger door is closed. Observe the courtesy lamps. Did the courtesy lamps go off?</p> <p>Yes → Replace the Driver Door Jamb Switch. Perform BODY VERIFICATION TEST - VER 1.</p> <p>No → Go To 3</p>	All

FRONT DOOR JAMB SWITCH CIRCUIT SHORT TO GROUND — Continued

TEST	ACTION	APPLICABILITY
3	<p>Turn the ignition off. Disconnect the Passenger Door Jamb Switch connector. Ensure the driver door is closed or the switch is disconnected. Observe the courtesy lamps. Did the courtesy lamps go off?</p> <p>Yes → Replace the Passenger Door Jamb Switch. Perform BODY VERIFICATION TEST - VER 1.</p> <p>No → Go To 4</p>	All
4	<p>Turn the ignition off. Disconnect the Security System Module C1 connector. Ensure the driver and passenger doors are closed or the switches are disconnected. Observe the courtesy lamps. Did the courtesy lamps go off?</p> <p>Yes → Replace the Security System Module in accordance with service information. Perform BODY VERIFICATION TEST - VER 1.</p> <p>No → Repair the Front Courtesy Lamps Control circuit for a short to ground. Perform BODY VERIFICATION TEST - VER 1.</p>	All

Symptom List:

**INTERNAL ERROR - SSM
TOWING INCLINATION SENSOR BEYOND LIMITS
TOWING INCLINATION SENSOR VALUE IS INVALID
TOWING INCLINATION SENSOR VALUE IS MISSING**

**Test Note: All symptoms listed above are diagnosed using the same tests.
The title for the tests will be INTERNAL ERROR - SSM.**

When Monitored and Set Condition:

INTERNAL ERROR - SSM

When Monitored: Whenever the battery voltage is above 10.0 volts and the Security System Module is connected.

Set Condition: If the internal module test fails this DTC will set.

TOWING INCLINATION SENSOR BEYOND LIMITS

When Monitored: Whenever the battery voltage is above 10.0 volts and the Security System Module is connected.

Set Condition: If the internal module test fails this DTC will set.

TOWING INCLINATION SENSOR VALUE IS INVALID

When Monitored: Whenever the battery voltage is above 10.0 volts and the Security System Module is connected.

Set Condition: If the internal module test fails this DTC will set.

TOWING INCLINATION SENSOR VALUE IS MISSING

When Monitored: Whenever the battery voltage is above 10.0 volts and the Security System Module is connected.

Set Condition: If the internal module test fails this DTC will set.

POSSIBLE CAUSES

DTC PRESENT

SECURITY SYSTEM MODULE FAILURE

INTERNAL ERROR - SSM — Continued

TEST	ACTION	APPLICABILITY
1	<p>With the DRBIII®, record and erase DTC's. Cycle the ignition switch from ON to OFF to ON. Wait 10 seconds. With the DRBIII®, read DTC's. Does the DRBIII® display the same DTC?</p> <p>Yes → Replace the Security System Module. Perform BODY VERIFICATION TEST - VER 1.</p> <p>No → Using the wiring diagram/schematic as a guide, inspect the wiring and connectors for an intermittent condition. Perform BODY VERIFICATION TEST - VER 1.</p>	All

Symptom:

INTRUSION SENSOR 1 CIRCUIT OPEN/SHORT TO GROUND

When Monitored and Set Condition:

INTRUSION SENSOR 1 CIRCUIT OPEN/SHORT TO GROUND

When Monitored: Whenever the battery voltage is above 10.0 volts and the Security System Module is connected.

Set Condition: The Security System Module detects the incorrect voltage on the Intrusion Sensor circuit.

POSSIBLE CAUSES

DTC PRESENT
 FUSE 2 IN FUSE BLOCK 3
 FUSED B(+) WIRE OPEN
 GROUND CIRCUIT OPEN
 INTRUSION SENSOR 1 SIGNAL SHORTED
 INTRUSION SENSOR 1 SIGNAL CIRCUIT OPEN
 INTRUSION SENSOR INTERFACE WIRE SHORTED
 INTRUSION SENSOR INTERFACE WIRE OPEN
 INTRUSION SENSOR

TEST	ACTION	APPLICABILITY
1	With the DRBIII®, record and erase DTC's. Remove the ignition key. Close and lock all doors and set the Vehicle Theft Security System. Wait 1 minute. Disarm the Vehicle Theft System. With the DRBIII®, read DTC's. Does the DRBIII® display the same DTC? Yes → Go To 2 No → Using the wiring diagram/schematic as a guide, inspect the wiring and connectors for an intermittent condition. Perform BODY VERIFICATION TEST - VER 1.	All
2	Check Fuse 2 in Fuse Block 3. Is the fuse open? Yes → Check for a short to ground and replace the fuse. Perform BODY VERIFICATION TEST - VER 1. No → Go To 3	All

INTRUSION SENSOR 1 CIRCUIT OPEN/SHORT TO GROUND — Continued

TEST	ACTION	APPLICABILITY
3	Disconnect the Intrusion Sensor No. 1 connector. Measure the voltage of the Fused B(+) circuit. Is the voltage above 10.0 volts? Yes → Go To 4 No → Repair the Fused B(+) circuit for an open. Perform BODY VERIFICATION TEST - VER 1.	All
4	Disconnect the Intrusion Sensor No. 1 connector. Measure the resistance of the Ground circuit at the Intrusion Sensor connector. Is the resistance below 5.0 ohms? Yes → Go To 5 No → Repair the Ground circuit for an open. Perform BODY VERIFICATION TEST - VER 1.	All
5	Turn the ignition off. Disconnect the Security System Module C2 connector. Disconnect the Intrusion Sensor No. 1 connector. Measure the resistance between ground and the Intrusion Sensor 1 Signal circuit. Is the resistance below 5.0 ohms? Yes → Repair the Intrusion Sensor 1 Signal wire for a short to ground. Perform BODY VERIFICATION TEST - VER 1. No → Go To 6	All
6	Disconnect the Intrusion Sensor No. 1 connector. Disconnect the Security System Module C2 connector. Measure the resistance of the Intrusion Sensor 1 Signal circuit between the SSM C2 connector and the Intrusion Sensor No 1 connector. Is the resistance below 5.0 ohms? Yes → Go To 7 No → Repair the Intrusion Sensor 1 Signal wire for an open. Perform BODY VERIFICATION TEST - VER 1.	All
7	Disconnect the Intrusion Sensor No. 1 connector. Disconnect the Security System Module C2 connector. Measure the resistance between ground and the Intrusion Sensor Interface circuit. Is the resistance below 5.0 ohms? Yes → Repair the Intrusion Sensor Interface circuit for a short to ground. Perform BODY VERIFICATION TEST - VER 1. No → Go To 8	All
8	Disconnect the Intrusion Sensor No. 1 connector. Disconnect the Security System Module C2 connector. Measure the resistance of the Intrusion Sensor Interface circuit between the SSM C2 connector and the Intrusion Sensor No. 1 connector. Is the resistance below 5.0 ohms? Yes → Replace the Intrusion Sensor. Perform BODY VERIFICATION TEST - VER 1. No → Repair the Intrusion Sensor Interface circuit for an open. Perform BODY VERIFICATION TEST - VER 1.	All

Symptom:

INTRUSION SENSOR 1 GROUND CIRCUIT OPEN

When Monitored and Set Condition:

INTRUSION SENSOR 1 GROUND CIRCUIT OPEN

When Monitored: Whenever the battery voltage is above 10.0 volts and the Security System Module is connected.

Set Condition: The Security System Module detects the incorrect voltage on the Intrusion Sensor circuit.

POSSIBLE CAUSES

DTC PRESENT
GROUND CIRCUIT OPEN
INTRUSION SENSOR

TEST	ACTION	APPLICABILITY
1	<p>With the DRBIII®, record and erase DTC's. Remove the ignition key. Close and lock all doors and set the Vehicle Theft Security System. Wait 1 minute. Disarm the Vehicle Theft System. With the DRBIII®, read DTC's. Does the DRBIII® display the same DTC?</p> <p>Yes → Go To 2</p> <p>No → Using the wiring diagram/schematic as a guide, inspect the wiring and connectors for an intermittent condition. Perform BODY VERIFICATION TEST - VER 1.</p>	All
2	<p>Disconnect the Intrusion Sensor No. 1 connector. Measure the resistance of the Ground circuit at the Intrusion Sensor connector. Is the resistance below 5.0 ohms?</p> <p>Yes → Replace the Intrusion Sensor. Perform BODY VERIFICATION TEST - VER 1.</p> <p>No → Repair the Ground circuit for an open. Perform BODY VERIFICATION TEST - VER 1.</p>	All

Symptom:

INTRUSION SENSOR 2 CIRCUIT OPEN/SHORT TO GROUND

When Monitored and Set Condition:

INTRUSION SENSOR 2 CIRCUIT OPEN/SHORT TO GROUND

When Monitored: Whenever the battery voltage is above 10.0 volts and the Security System Module is connected.

Set Condition: The Security System Module detects the incorrect voltage on the Intrusion Sensor circuit.

POSSIBLE CAUSES

- DTC PRESENT
- FUSE 2 IN FUSE BLOCK 3
- FUSED B(+) WIRE OPEN
- GROUND CIRCUIT OPEN
- INTRUSION SENSOR 2 SIGNAL SHORTED
- INTRUSION SENSOR 2 SIGNAL CIRCUIT OPEN
- INTRUSION SENSOR INTERFACE WIRE SHORTED
- INTRUSION SENSOR INTERFACE WIRE OPEN
- INTRUSION SENSOR

TEST	ACTION	APPLICABILITY
1	With the DRBIII®, record and erase DTC's. Remove the ignition key. Close and lock all doors and set the Vehicle Theft Security System. Wait 1 minute. Disarm the Vehicle Theft System. With the DRBIII®, read DTC's. Does the DRBIII® display the same DTC? Yes → Go To 2 No → Using the wiring diagram/schematic as a guide, inspect the wiring and connectors for an intermittent condition. Perform BODY VERIFICATION TEST - VER 1.	All
2	Check Fuse 2 in Fuse Block 3. Is the fuse open? Yes → Check for a short to ground and replace the fuse. Perform BODY VERIFICATION TEST - VER 1. No → Go To 3	All

INTRUSION SENSOR 2 CIRCUIT OPEN/SHORT TO GROUND — Continued

TEST	ACTION	APPLICABILITY
3	Disconnect the Intrusion Sensor No. 2 connector. Measure the voltage of the Fused B(+) circuit. Is the voltage above 10.0 volts? Yes → Go To 4 No → Repair the Fused B(+) circuit for an open. Perform BODY VERIFICATION TEST - VER 1.	All
4	Disconnect the Intrusion Sensor No. 2 connector. Measure the resistance of the Ground circuit at the Intrusion Sensor connector. Is the resistance below 5.0 ohms? Yes → Go To 5 No → Repair the Ground circuit for an open. Perform BODY VERIFICATION TEST - VER 1.	All
5	Turn the ignition off. Disconnect the Security System Module C2 connector. Disconnect the Intrusion Sensor No. 2 connector. Measure the resistance between ground and the Intrusion Sensor 2 Signal circuit. Is the resistance below 5.0 ohms? Yes → Repair the Intrusion Sensor 2 Signal wire for a short to ground. Perform BODY VERIFICATION TEST - VER 1. No → Go To 6	All
6	Disconnect the Intrusion Sensor No. 2 connector. Disconnect the Security System Module C2 connector. Measure the resistance of the Intrusion Sensor 2 Signal circuit between the SSM C2 connector and the Intrusion Sensor No 2 connector. Is the resistance below 5.0 ohms? Yes → Go To 7 No → Repair the Intrusion Sensor 2 Signal wire for an open. Perform BODY VERIFICATION TEST - VER 1.	All
7	Disconnect the Intrusion Sensor No. 2 connector. Disconnect the Security System Module C2 connector. Measure the resistance between ground and the Intrusion Sensor Interface circuit. Is the resistance below 5.0 ohms? Yes → Repair the Intrusion Sensor Interface circuit for a short to ground. Perform BODY VERIFICATION TEST - VER 1. No → Go To 8	All
8	Disconnect the Intrusion Sensor No. 2 connector. Disconnect the Security System Module C2 connector. Measure the resistance of the Intrusion Sensor Interface circuit between the SSM C2 connector and the Intrusion Sensor No. 2 connector. Is the resistance below 5.0 ohms? Yes → Replace the Intrusion Sensor. Perform BODY VERIFICATION TEST - VER 1. No → Repair the Intrusion Sensor Interface circuit for an open. Perform BODY VERIFICATION TEST - VER 1.	All

Symptom:

INTRUSION SENSOR 2 GROUND CIRCUIT OPEN

When Monitored and Set Condition:

INTRUSION SENSOR 2 GROUND CIRCUIT OPEN

When Monitored: Whenever the battery voltage is above 10.0 volts and the Security System Module is connected.

Set Condition: The Security System Module detects the incorrect voltage on the Intrusion Sensor circuit.

POSSIBLE CAUSES

DTC PRESENT
GROUND CIRCUIT OPEN
INTRUSION SENSOR

TEST	ACTION	APPLICABILITY
1	With the DRBIII®, record and erase DTC's. Remove the ignition key. Close and lock all doors and set the Vehicle Theft Security System. Wait 1 minute. Disarm the Vehicle Theft System. With the DRBIII®, read DTC's. Does the DRBIII® display the same DTC? Yes → Go To 2 No → Using the wiring diagram/schematic as a guide, inspect the wiring and connectors for an intermittent condition. Perform BODY VERIFICATION TEST - VER 1.	All
2	Disconnect the Intrusion Sensor No. 2 connector. Measure the resistance of the Ground circuit at the Intrusion Sensor connector. Is the resistance below 5.0 ohms? Yes → Replace the Intrusion Sensor. Perform BODY VERIFICATION TEST - VER 1. No → Repair the Ground circuit for an open. Perform BODY VERIFICATION TEST - VER 1.	All

Symptom:

INTRUSION SENSOR 3 CIRCUIT OPEN/SHORT TO GROUND

When Monitored and Set Condition:

INTRUSION SENSOR 3 CIRCUIT OPEN/SHORT TO GROUND

When Monitored: Whenever the battery voltage is above 10.0 volts and the Security System Module is connected.

Set Condition: The Security System Module detects the incorrect voltage on the Intrusion Sensor circuit.

POSSIBLE CAUSES

DTC PRESENT
 FUSE 2 IN FUSE BLOCK 3
 FUSED B(+) WIRE OPEN
 GROUND CIRCUIT OPEN
 INTRUSION SENSOR 3 SIGNAL SHORTED
 INTRUSION SENSOR 3 SIGNAL CIRCUIT OPEN
 INTRUSION SENSOR INTERFACE WIRE SHORTED
 INTRUSION SENSOR INTERFACE WIRE OPEN
 INTRUSION SENSOR

TEST	ACTION	APPLICABILITY
1	With the DRBIII®, record and erase DTC's. Remove the ignition key. Close and lock all doors and set the Vehicle Theft Security System. Wait 1 minute. Disarm the Vehicle Theft System. With the DRBIII®, read DTC's. Does the DRBIII® display the same DTC? Yes → Go To 2 No → Using the wiring diagram/schematic as a guide, inspect the wiring and connectors for an intermittent condition. Perform BODY VERIFICATION TEST - VER 1.	All
2	Check Fuse 2 in Fuse Block 3. Is the fuse open? Yes → Check for a short to ground and replace the fuse. Perform BODY VERIFICATION TEST - VER 1. No → Go To 3	All

INTRUSION SENSOR 3 CIRCUIT OPEN/SHORT TO GROUND — Continued

TEST	ACTION	APPLICABILITY
3	Disconnect the Intrusion Sensor No. 3 connector. Measure the voltage of the Fused B(+) circuit. Is the voltage above 10.0 volts? Yes → Go To 4 No → Repair the Fused B(+) circuit for an open. Perform BODY VERIFICATION TEST - VER 1.	All
4	Disconnect the Intrusion Sensor No. 3 connector. Measure the resistance of the Ground circuit at the Intrusion Sensor connector. Is the resistance below 5.0 ohms? Yes → Go To 5 No → Repair the Ground circuit for an open. Perform BODY VERIFICATION TEST - VER 1.	All
5	Turn the ignition off. Disconnect the Security System Module C2 connector. Disconnect the Intrusion Sensor No. 3 connector. Measure the resistance between ground and the Intrusion Sensor 3 Signal circuit. Is the resistance below 5.0 ohms? Yes → Repair the Intrusion Sensor 3 Signal wire for a short to ground. Perform BODY VERIFICATION TEST - VER 1. No → Go To 6	All
6	Disconnect the Intrusion Sensor No. 3 connector. Disconnect the Security System Module C2 connector. Measure the resistance of the Intrusion Sensor 3 Signal circuit between the SSM C2 connector and the Intrusion Sensor No 3 connector. Is the resistance below 5.0 ohms? Yes → Go To 7 No → Repair the Intrusion Sensor 3 Signal wire for an open. Perform BODY VERIFICATION TEST - VER 1.	All
7	Disconnect the Intrusion Sensor No. 3 connector. Disconnect the Security System Module C2 connector. Measure the resistance between ground and the Intrusion Sensor Interface circuit. Is the resistance below 5.0 ohms? Yes → Repair the Intrusion Sensor Interface circuit for a short to ground. Perform BODY VERIFICATION TEST - VER 1. No → Go To 8	All
8	Disconnect the Intrusion Sensor No. 3 connector. Disconnect the Security System Module C2 connector. Measure the resistance of the Intrusion Sensor Interface circuit between the SSM C2 connector and the Intrusion Sensor No. 3 connector. Is the resistance below 5.0 ohms? Yes → Replace the Intrusion Sensor. Perform BODY VERIFICATION TEST - VER 1. No → Repair the Intrusion Sensor Interface circuit for an open. Perform BODY VERIFICATION TEST - VER 1.	All

Symptom:

INTRUSION SENSOR 3 GROUND CIRCUIT OPEN

When Monitored and Set Condition:

INTRUSION SENSOR 3 GROUND CIRCUIT OPEN

When Monitored: Whenever the battery voltage is above 10.0 volts and the Security System Module is connected.

Set Condition: The Security System Module detects the incorrect voltage on the Intrusion Sensor circuit.

POSSIBLE CAUSES

DTC PRESENT
GROUND CIRCUIT OPEN
INTRUSION SENSOR

TEST	ACTION	APPLICABILITY
1	<p>With the DRBIII®, record and erase DTC's. Remove the ignition key. Close and lock all doors and set the Vehicle Theft Security System. Wait 1 minute. Disarm the Vehicle Theft System. With the DRBIII®, read DTC's. Does the DRBIII® display the same DTC?</p> <p>Yes → Go To 2</p> <p>No → Using the wiring diagram/schematic as a guide, inspect the wiring and connectors for an intermittent condition. Perform BODY VERIFICATION TEST - VER 1.</p>	All
2	<p>Disconnect the Intrusion Sensor No. 3 connector. Measure the resistance of the Ground circuit at the Intrusion Sensor connector. Is the resistance below 5.0 ohms?</p> <p>Yes → Replace the Intrusion Sensor. Perform BODY VERIFICATION TEST - VER 1.</p> <p>No → Repair the Ground circuit for an open. Perform BODY VERIFICATION TEST - VER 1.</p>	All

Symptom:

REAR OR SLIDING DOOR JAMB SWITCH CIRCUIT SHORT TO GROUND

When Monitored and Set Condition:

REAR OR SLIDING DOOR JAMB SWITCH CIRCUIT SHORT TO GROUND

When Monitored: Whenever the battery voltage is above 10.0 volts and the Security System Module is connected.

Set Condition: If a rear or sliding door jamb switch is closed or the rear courtesy lamps control circuit is grounded for over 30 minutes, this code will set.

POSSIBLE CAUSES
DTC PRESENT
SLIDING DOOR JAMB SWITCH SHORTED
REAR DOOR JAMB SWITCH SHORTED
SECURITY SYSTEM MODULE SHORTED
REAR COURTESY LAMPS CONTROL SHORT TO GROUND

TEST	ACTION	APPLICABILITY
1	<p>NOTE: Ensure the courtesy lamp switches operate properly before proceeding.</p> <p>NOTE: If this code is active, the rear courtesy lamps will remain on with all the doors closed.</p> <p>With the DRBIII®, record and erase DTC's.</p> <p>Cycle the ignition switch from ON to OFF to ON.</p> <p>With the DRBIII®, read DTC's.</p> <p>Open and close the sliding and rear doors several times while observing the DRBIII®.</p> <p>Wait 10 seconds.</p> <p>Does the DRBIII® display REAR OR SLIDING DOOR JAMB SWITCH CIRCUIT SHORT TO GROUND?</p> <p style="padding-left: 40px;">Yes → Go To 2</p> <p style="padding-left: 40px;">No → The conditions that caused this code to set are not present at this time. Using the wiring diagram/schematic as a guide, inspect the wiring and connectors for an intermittent condition.</p> <p style="padding-left: 40px;">Perform BODY VERIFICATION TEST - VER 1.</p>	All
2	<p>Turn the ignition off.</p> <p>Disconnect the Right and then the Left (if equipped) Sliding Door Jamb Switch connector.</p> <p>Observe the courtesy lamps.</p> <p>Did the courtesy lamps go off when one of the switches was disconnected?</p> <p style="padding-left: 40px;">Yes → Replace the Sliding Door Jamb Switch.</p> <p style="padding-left: 40px;">Perform BODY VERIFICATION TEST - VER 1.</p> <p style="padding-left: 40px;">No → Go To 3</p>	All

REAR OR SLIDING DOOR JAMB SWITCH CIRCUIT SHORT TO GROUND

— Continued

TEST	ACTION	APPLICABILITY
3	Turn the ignition off. Disconnect the Rear Door Jamb Switch connector. Ensure the sliding door(s) are closed or the switches are disconnected. Observe the courtesy lamps. Did the courtesy lamps go off? Yes → Replace the Rear Door Jamb Switch. Perform BODY VERIFICATION TEST - VER 1. No → Go To 4	All
4	Turn the ignition off. Disconnect the Security System Module C1 connector. Ensure the sliding and rear doors are closed or the switches are disconnected. Observe the courtesy lamps. Did the courtesy lamps go off? Yes → Replace the Security System Module in accordance with service information. Perform BODY VERIFICATION TEST - VER 1. No → Repair the Rear Courtesy Lamps Control circuit for a short to ground. Perform BODY VERIFICATION TEST - VER 1.	All

Symptom:

RKE INTERFACE CIRCUIT FAILURE - SSM

When Monitored and Set Condition:

RKE INTERFACE CIRCUIT FAILURE - SSM

When Monitored: Whenever the battery voltage is above 10.0 volts and the Security System Module is connected.

Set Condition: If the Security System Module senses a poor or no connection to the Central Timer Module, this code will set.

POSSIBLE CAUSES

- DTC PRESENT
- SECURITY SYSTEM MODULE SHORTED
- RKE INTERFACE WIRE SHORTED
- RKE INTERFACE WIRE OPEN
- CENTRAL TIMER MODULE FAILURE

TEST	ACTION	APPLICABILITY
1	With the DRBIII®, record and erase DTC's. Cycle the ignition switch from ON to OFF to ON. With the DRBIII®, read DTC's. Remove the ignition key. Using the RKE transmitter, operate the Door Locks several times while observing the DRBIII®. Wait 10 seconds. Does the DRBIII® display RKE INTERFACE CIRCUIT FAILURE? Yes → Go To 2 No → Using the wiring diagram/schematic as a guide, inspect the wiring and connectors for an intermittent condition. Using the RKE transmitter, operate the door locks several times and re-check for any DTC's. Perform BODY VERIFICATION TEST - VER 1.	All
2	Turn the ignition off. Disconnect the Security System Module C2 connector. Measure the resistance between ground and the RKE Interface circuit. Is the resistance between 5500.0 (5.5K) and 6500.0 (6.5K) ohms? Yes → Replace the Security System Module. Perform BODY VERIFICATION TEST - VER 1. No → Go To 3	All

VEHICLE THEFT/SECURITY

RKE INTERFACE CIRCUIT FAILURE - SSM — Continued

TEST	ACTION	APPLICABILITY
3	<p>Disconnect the Central Timer Module C1 connector. Disconnect the Security System Module C2 connector. Measure the resistance between ground and the RKE Interface circuit. Is the resistance below 20000.0 ohms?</p> <p>Yes → Repair the RKE Interface circuit for a short to ground. Perform BODY VERIFICATION TEST - VER 1.</p> <p>No → Go To 4</p>	All
4	<p>Disconnect the Central Timer Module C1 connector. Disconnect the Security System Module C2 connector. Measure the resistance of the RKE Interface circuit between the SSM C2 connector and the CTM C1 connector. Is the resistance below 5.0 ohms?</p> <p>Yes → Replace the Central Timer Module. Perform BODY VERIFICATION TEST - VER 1.</p> <p>No → Repair the RKE Interface circuit for an open. Perform BODY VERIFICATION TEST - VER 1.</p>	All

Symptom:

SECURITY SYSTEM INTERFACE FAILURE - SSM

When Monitored and Set Condition:

SECURITY SYSTEM INTERFACE FAILURE - SSM

When Monitored: Whenever the battery voltage is above 10.0 volts and the Security System Module is connected.

Set Condition: If the Security System Module senses a poor or no connection to the Sentry Key Remote Entry Module, this code will set.

POSSIBLE CAUSES

- DTC PRESENT
- SENTRY KEY REMOTE MODULE MODULE SHORTED
- SECURITY SYSTEM INTERFACE WIRE SHORTED
- SECURITY SYSTEM INTERFACE WIRE OPEN
- SECURITY SYSTEM MODULE FAILURE

TEST	ACTION	APPLICABILITY
1	<p>With the DRBIII®, record and erase DTC's. Cycle the ignition switch from ON to OFF to ON. With the DRBIII®, read DTC's. Using the RKE transmitter, operate the Door Locks several times while observing the DRBIII®. Wait 10 seconds. Does the DRBIII® display SECURITY SYSTEM INTERFACE CIRCUIT FAILURE?</p> <p>Yes → Go To 2</p> <p>No → Using the wiring diagram/schematic as a guide, inspect the wiring and connectors for an intermittent condition. Using the RKE transmitter, operate the door locks several times and re-check for any DTC's. Perform BODY VERIFICATION TEST - VER 1.</p>	All
2	<p>Turn the ignition off. Disconnect the SENTRY KEY REMOTE ENTRY MODULE connector. Measure the resistance between ground and the Security System Interface circuit. Is the resistance between 5200.0 (5.2K) and 6800.0 (6.8K) ohms?</p> <p>Yes → Replace the Sentry Key Remote Entry Module. Perform BODY VERIFICATION TEST - VER 1.</p> <p>No → Go To 3</p>	All

SECURITY SYSTEM INTERFACE FAILURE - SSM — Continued

TEST	ACTION	APPLICABILITY
3	Disconnect the Sentry Key Remote Entry Module connector. Disconnect the Security System Module C2 connector. Measure the resistance between ground and the Security System Interface circuit. Is the resistance below 20000.0 ohms? Yes → Repair the Security System Interface circuit for a short to ground. Perform BODY VERIFICATION TEST - VER 1. No → Go To 4	All
4	Disconnect the Sentry Key Remoter Entry connector. Disconnect the Security System Module C2 connector. Measure the resistance of the Security System circuit between the SSM C2 connector and the CTM C1 connector. Is the resistance below 5.0 ohms? Yes → Replace the Security System Module. Perform BODY VERIFICATION TEST - VER 1. No → Repair the Security System Interface circuit for an open. Perform BODY VERIFICATION TEST - VER 1.	All

Symptom:
SIREN CIRCUIT OPEN/SHORTED TO GROUND

When Monitored and Set Condition:

SIREN CIRCUIT OPEN/SHORTED TO GROUND

When Monitored: Whenever the battery voltage is above 10.0 volts and the Security System Module is connected.

Set Condition: The Security System Module detects the incorrect voltage on the Siren Signal Control circuit.

POSSIBLE CAUSES	
DTC PRESENT	
FUSE 2 IN FUSE BLOCK 3	
FUSED B(+) WIRE OPEN	
GROUND CIRCUIT OPEN	
SIREN SIGNAL CONTROL WIRE SHORTED	
SIREN SIGNAL CONTROL WIRE OPEN	
SIREN	

TEST	ACTION	APPLICABILITY
1	With the DRBIII®, record and erase DTC's. Remove the ignition key. Close and lock all doors and set the Vehicle Theft Security System. Wait 1 minute. Disarm the Vehicle Theft System. With the DRBIII®, read DTC's. Does the DRBIII® display the same DTC? Yes → Go To 2 No → Using the wiring diagram/schematic as a guide, inspect the wiring and connectors for an intermittent condition. Perform BODY VERIFICATION TEST - VER 1.	All
2	Check Fuse 2 in Fuse Block 3. Is the fuse open? Yes → Check for a short to ground and replace the fuse. Perform BODY VERIFICATION TEST - VER 1. No → Go To 3	All
3	Disconnect the Siren connector. Measure the voltage of the Fused B(+) circuit. Is the voltage above 10.0 volts? Yes → Go To 4 No → Repair the Fused B(+) circuit for an open. Perform BODY VERIFICATION TEST - VER 1.	All

SIREN CIRCUIT OPEN/SHORTED TO GROUND — Continued

TEST	ACTION	APPLICABILITY
4	Disconnect the Siren connector. Measure the resistance of the Ground circuit at the Siren connector. Is the resistance below 5.0 ohms? Yes → Go To 5 No → Repair the Ground circuit for an open. Perform BODY VERIFICATION TEST - VER 1.	All
5	Disconnect the Siren connector. Disconnect the Security System Module C2 connector. Measure the resistance between ground and the Siren Signal Control circuit. Is the resistance below 5.0 ohms? Yes → Repair the Siren Signal Control circuit for a short to ground. Perform BODY VERIFICATION TEST - VER 1. No → Go To 6	All
6	Disconnect the Siren connector. Disconnect the Security System Module C2 connector. Measure the resistance of the Siren Signal Control circuit between the SSM C2 connector and the Siren connector. Is the resistance below 5.0 ohms? Yes → Replace the Siren. Perform BODY VERIFICATION TEST - VER 1. No → Repair the Siren Signal Control circuit for an open. Perform BODY VERIFICATION TEST - VER 1.	All

Symptom:
SIREN INTERNAL FAILURE

When Monitored and Set Condition:

SIREN INTERNAL FAILURE

When Monitored: Whenever the battery voltage is above 10.0 volts and the Security System Module is connected.

Set Condition: If the Siren internal test fails this DTC will set.

POSSIBLE CAUSES

DTC PRESENT
 SIREN ACTUATION
 SIREN

TEST	ACTION	APPLICABILITY
1	With the DRBIII®, record and erase DTC's. Remove the ignition key. Close and lock all doors and set the Vehicle Theft Security System. Wait 1 minute. Disarm the Vehicle Theft System. With the DRBIII®, read DTC's. Does the DRBIII® display the same DTC? Yes → Go To 2 No → Using the wiring diagram/schematic as a guide, inspect the wiring and connectors for an intermittent condition. Perform BODY VERIFICATION TEST - VER 1.	All
2	With the DRBIII®, actuate the Siren. Did the siren sound with the actuation and does the Siren function properly otherwise? Yes → This DTC can be ignored if there are no other complaints with the operation of the Siren. Perform BODY VERIFICATION TEST - VER 1. No → Replace the Siren. Perform BODY VERIFICATION TEST - VER 1.	All

Symptom:

SIREN SIGNAL CONTROL CIRCUIT SHORT TO GROUND

When Monitored and Set Condition:

SIREN SIGNAL CONTROL CIRCUIT SHORT TO GROUND

When Monitored: Whenever the battery voltage is above 10.0 volts and the Security System Module is connected.

Set Condition: The Security System Module detects a short to ground on the Siren Signal Control circuit.

POSSIBLE CAUSES

DTC PRESENT

SIREN SIGNAL CONTROL WIRE SHORTED

SIREN

TEST	ACTION	APPLICABILITY
1	<p>With the DRBIII®, record and erase DTC's. Remove the ignition key. Close and lock all doors and set the Vehicle Theft Security System. Wait 1 minute. Disarm the Vehicle Theft System. With the DRBIII®, read DTC's. Does the DRBIII® display the same DTC?</p> <p>Yes → Go To 2</p> <p>No → Using the wiring diagram/schematic as a guide, inspect the wiring and connectors for an intermittent condition. Perform BODY VERIFICATION TEST - VER 1.</p>	All
2	<p>Disconnect the Siren connector. Disconnect the Security System Module C2 connector. Measure the resistance between ground and the Siren Signal Control circuit. Is the resistance below 5.0 ohms?</p> <p>Yes → Repair the Siren Signal Control circuit for a short to ground. Perform BODY VERIFICATION TEST - VER 1.</p> <p>No → Replace the Siren. Perform BODY VERIFICATION TEST - VER 1.</p>	All

Verification Tests

ABS VERIFICATION TEST - VER 1	APPLICABILITY
<p>1. Turn the ignition off.</p> <p>2. Connect all previously disconnected components and connectors.</p> <p>3. Ensure all accessories are turned off and the battery is fully charged.</p> <p>4. Ensure that the Ignition is on, and with the DRBIII, erase all Diagnostic Trouble Codes from ALL modules. Start the engine and allow it to run for 2 minutes and fully operate the system that was malfunctioning.</p> <p>5. Turn the ignition off and wait 5 seconds. Turn the ignition on and using the DRBIII, read DTC's from ALL modules.</p> <p>6. If any Diagnostic Trouble Codes are present, return to Symptom list and troubleshoot new or recurring symptom.</p> <p>7. NOTE: If the CAB/HCU was replaced, ensure the CAB has been initialized</p> <p>8. NOTE: If the SKREEM or ECM was replaced, refer to the service information for proper programming procedures.</p> <p>9. NOTE: For Sensor Circuit/Signal and Pump Motor faults, the CAB must sense all 4 wheels at 12 km/h (8 mph) before it will extinguish the ABS Indicator.</p> <p>10. If there are no DTC's present after turning ignition on, road test the vehicle for at least 5 minutes. Perform several antilock braking stops.</p> <p>11. CAUTION: Ensure braking capability is available before road testing.</p> <p>12. Again, with the DRBIII® read DTC's. If any DTC's are present, return to Symptom list.</p> <p>13. If there are no Diagnostic Trouble Codes (DTC's) present, and the customer's concern can no longer be duplicated, the repair is complete.</p> <p>Are any DTC's present or is the original concern still present?</p> <p>Yes → Repair is not complete, refer to appropriate symptom.</p> <p>No → Repair is complete.</p>	<p>All</p>

AIRBAG VERIFICATION TEST - VER 1	APPLICABILITY
<p>1. Remove any special tools or jumper wires and reconnect all previously disconnected components - except the Battery.</p> <p>2. WARNING: TO AVOID PERSONAL INJURY OR DEATH, TURN THE IGNITION ON, THEN RECONNECT THE BATTERY.</p> <p>3. Connect the DRBIII® to the Data Link Connector - use the most current software available.</p> <p>4. Use the DRBIII® and erase the stored codes in all airbag system modules.</p> <p>5. Turn the ignition off, and wait 15 seconds, then turn the ignition on.</p> <p>6. Wait one minute, and read active codes and if there are none present read the stored codes.</p> <p>7. Note: If equipped with Airbag On - Off switch, read the DTC's in all switch positions.</p> <p>8. Note: Read the DTC's in all airbag system related modules.</p> <p>9. If the DRBIII® shows any active or stored codes, return to the Symptom list and follow path specified for that trouble code. If no active or stored codes are present, the repair is complete.</p> <p>Are any DTC's present or is the original condition still present?</p> <p>YES Repair is not complete, refer to appropriate symptom list.</p> <p>NO Repair is complete.</p>	<p>All</p>

Verification Tests — Continued

BODY VERIFICATION TEST - VER 1	APPLICABILITY
<p>1. Disconnect all jumper wires and reconnect all previously disconnected components and connectors.</p> <p>2. Ensure that all accessories are turned off and the battery is fully charged.</p> <p>3. NOTE: Refer to the service information for proper programming procedures if the ABM; ACM; ATC; CTM; ECM; IC; SKREEM; SLA; or SSM was replaced.</p> <p>4. If the SKREEM was replaced, program all RKE transmitters used with this vehicle.</p> <p>5. NOTE: Perform the next 8 steps of this procedure if either diagnosing the Automatic Temperature Control (ATC) system or if repairs were made to the ATC system. All of the following criteria must be met in order to successfully run the ATC Function Test.</p> <p>6. With DRBIII®, record and erase ATC DTCs.</p> <p>7. Place the shift lever in Park.</p> <p>8. Start the engine. Allow the engine to reach normal operating temperature.</p> <p>9. Set the blower to high speed.</p> <p>10. Press the Air Conditioning switch On.</p> <p>11. With the DRBIII®, verify that the ambient temperature is above 59°F (15°C), the refrigerant pressure is between 29 and 348 PSI (2 and 24 bar), the evaporator temperature is above 36.5°F (2.5°C), and the coolant temperature is above 158°F (70°C).</p> <p>12. With the DRBIII® in ATC, select System Tests and select ATC Function Test. When the ATC Function Test is complete, proceed to the next step of this procedure.</p> <p>13. With the DRBIII®, read active ATC DTCs. If any DTC is active or if the original condition is still present, proceed to the conclusion question and answer Yes.</p> <p>14. With the DRBIII®, record and erase all DTCs from ALL modules. Start and run the engine for 2 minutes. Operate all functions of the system that caused the original concern.</p> <p>15. Turn the ignition off and wait 5 seconds. Turn the ignition on and using the DRBIII®, read DTCs from ALL modules.</p> <p>Are any DTC's present or is the original condition still present?</p> <p>Yes → Repair is not complete, refer to the appropriate symptom.</p> <p>No → Repair is complete.</p>	<p>All</p>

Verification Tests — Continued

HEATER VERIFICATION TEST - VER 1	APPLICABILITY
<p>1. WARNING: NEVER OPERATE THE HEATER IN AN ENCLOSED AREA THAT DOES NOT HAVE EXHAUST VENTILATION FACILITIES. ALWAYS VENT THE HEATER'S EXHAUST WHEN OPERATING THE HEATER. FAILURE TO FOLLOW THESE INSTRUCTIONS CAN RESULT IN PERSONAL INJURY OR DEATH.</p> <p>2. WARNING: ALLOW THE HEATER ASSEMBLY TO COOL BEFORE PERFORMING A COMPONENT INSPECTION/REPAIR/REPLACEMENT. FAILURE TO FOLLOW THESE INSTRUCTIONS CAN RESULT IN PERSONAL INJURY OR DEATH.</p> <p>3. NOTE: The heater's control unit will store up to five DTCs in its memory.</p> <p>4. NOTE: If the heater's control unit detects a new fault in the system, one that is not already stored in its memory, it will clear the oldest of the five stored DTCs, and it will store the new fault's DTC.</p> <p>5. NOTE: If the heater's control unit detects a reoccurrence of a stored fault, it will overwrite that fault's DTC with the most recent occurrence.</p> <p>6. Verify that the vehicle's battery is fully charged.</p> <p>7. Verify that there is more than 1/8 of a tank of fuel in the vehicle's fuel tank. Add fuel, if necessary.</p> <p>8. Verify that all heater's coolant hoses and fuel lines are securely fastened to their respective components.</p> <p>9. Disconnect all jumper wires and reconnect all previously disconnected components and connectors.</p> <p>10. If a heater installation/cooling system service was performed, purge the coolant circuit of air in accordance with the Service Information.</p> <p>11. Turn the ignition on.</p> <p>12. Verify that the Cabin Heater or Heater Booster is switched off.</p> <p>13. Ensure that all accessories are turned off.</p> <p>14. Set the blend control to the max heat position and the mode control to the floor position.</p> <p>15. If a fuel system service requiring fuel to drain out of the heater's fuel line was performed, prime the heater's Dosing Pump in accordance with the Service Information.</p> <p>16. With the DRBIII®, record and erase all DTCs from the Cabin Heater Module or Heater Booster Module. Turn the ignition off, wait 5 seconds, then turn start the engine.</p> <p>17. Allow the engine to idle.</p> <p>18. NOTE: Do not disconnect the vehicle's battery or the heater's main power supply while the heater is in operation or in run-down mode. Failure to follow these instructions can result in excess emissions from the heater during heater operation.</p> <p>19. Switch the Cabin Heater or Heater Booster on. Allow the heater to run through at least one cycle of operation (approximately 10 minutes), and then turn the heater off.</p> <p>20. With the DRBIII®, read the Cabin Heater or Heater Booster Module's DTC.</p> <p>21. Turn the engine off.</p> <p>Are any DTC's present or is the original condition still present?</p> <p>Yes → Repair is not complete, refer to the appropriate symptom.</p> <p>No → Repair is complete.</p>	<p>All</p>

VERIFICATION TESTS

Verification Tests — Continued

NAG1 TRANSMISSION VERIFICATION TEST - VER 1	APPLICABILITY
<ol style="list-style-type: none"> 1. Reconnect any disconnected components. 2. Connect the DRBIII® to the Data Link Connector. 3. With the DRBIII®, erase ABS DTCs. 4. With the DRBIII®, erase ECM DTCs. 5. With the DRBIII®, erase Transmission DTCs. 6. With the DRBIII®, display Transmission Temperature. Start and run the engine until the Transmission Temperature is HOT, above 43° C (110° F). 7. Check the Transmission fluid and adjust if necessary. Refer to the Service Information for the proper Fluid Fill procedure. 8. NOTE: If internal repairs were performed and the shift quality is still poor, it may be necessary to check the internal repair. Also check for any TSBs and/or Controller Flash updates that may apply. 9. ROAD TEST PROCEDURE 10. Road test the vehicle. Make fifteen to twenty 1-2, 2-3, 3-4 and 4-5 upshifts. 11. Perform these shifts from a standing start to 72 km/h (45 MPH) with a constant throttle opening of 20 to 25 degrees. 12. With speeds below 40 km/h (25 MPH), make five to eight wide open throttle kickdowns to 1st gear. Allow at least 5 seconds each in 2nd and 3rd gear between each kickdown. 13. With the DRBIII®, read Transmission DTCs. <p>Were there any Diagnostic Trouble Codes set?</p> <p style="padding-left: 40px;">Yes → Repair is not complete, refer to appropriate symptom.</p> <p style="padding-left: 40px;">No → Repair is complete.</p>	<p>All</p>

ROAD TEST VERIFICATION - VER-2	APPLICABILITY
<ol style="list-style-type: none"> 1. Inspect the vehicle to ensure that all engine components are properly installed and connected. Reassemble and reconnect components as necessary. 2. If this verification procedure is being performed after a non-DTC test, perform steps 3 and 4. 3. Check to see if the initial symptom still exists. If there are no trouble codes and the symptom no longer exists, the repair was successful and testing is now complete. 4. If the initial or another symptom exists, the repair is not complete. Check all pertinent Technical Service Bulletins (TSBs) and return to the Symptom List if necessary. 5. For previously read DTCs that have not been dealt with, return to the Symptom List and follow the diagnostic path for that DTC; otherwise, continue. 6. If the Engine Control Module (ECM) has not been changed, perform steps 7 and 8, otherwise, continue with step 9. 7. With the DRB III®, erase all diagnostic trouble codes (DTCs), then disconnect the DRB III®. 8. Turn the ignition off for at least 10 seconds. 9. If equipped with a Transfer Case Position Switch, perform step 10, otherwise, continue with step 11. 10. With the ignition switch on, place the Transfer Case Shift Lever in each gear position, stopping for 15 seconds in each position. 11. Ensure no DTCs remain by performing steps 12 through 15. 12. Road test the vehicle. For some of the road test, go at least 64 km/h (40 MPH). If this test is for an A/C Relay Control Circuit, drive the vehicle for at least 5 minutes with the A/C on. 13. At some point, stop the vehicle and turn the engine off for at least 10 seconds, then restart the engine and continue. 14. Upon completion of the road test, turn the engine off and check for DTCs with the DRB III®. 15. If the repaired DTC has set again, the repair is not complete. Check for any pertinent Technical Service Bulletins (TSBs) and return to the Symptom List. If there are no DTCs, the repair was successful and is now complete. <p>Are any DTCs or symptoms remaining?</p> <p style="padding-left: 40px;">Yes → Repair is not complete, refer to appropriate symptom.</p> <p style="padding-left: 40px;">No → Repair is complete.</p>	<p>All</p>

8.0 COMPONENT LOCATIONS

8.1 AIRBAG SYSTEM

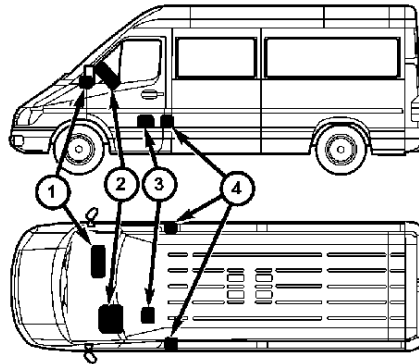

- 1 - PASSENGER AIRBAG (OPTIONAL)
- 2 - DRIVER AIRBAG
- 3 - AIRBAG CONTROL MODULE
- 4 - SEAT BELT TENSIONER (DRIVER SIDE-STANDARD, PASSENGER SIDE-OPTIONAL WITH PASSENGER AIRBAG ONLY)

810f9fcc

8.2 AIRBAG CONTROL MODULE

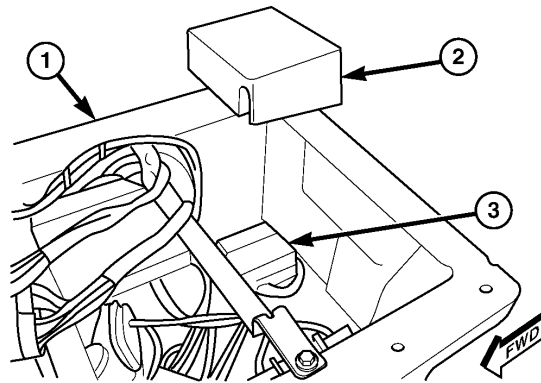

- 1 - DRIVER SEAT RISER
- 2 - ACM COVER
- 3 - ACM

810fa015

8.3 DRIVER AIRBAG SQUIB

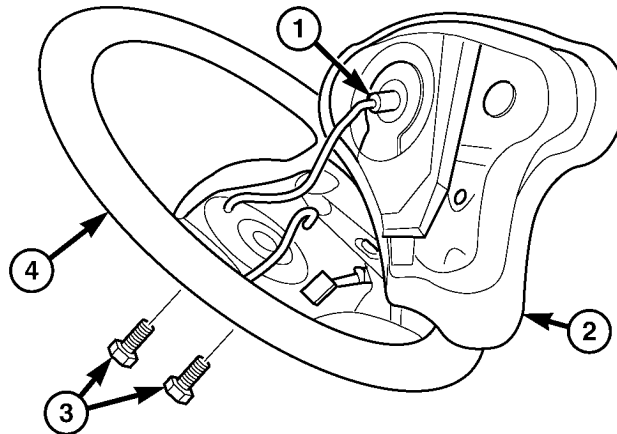

- 1 - AIRBAG SQUIB CONNECTOR
- 2 - DRIVER AIRBAG
- 3 - SCREW (2)
- 4 - STEERING WHEEL

810fa064

COMPONENT LOCATIONS

8.4 CLOCKSPRING

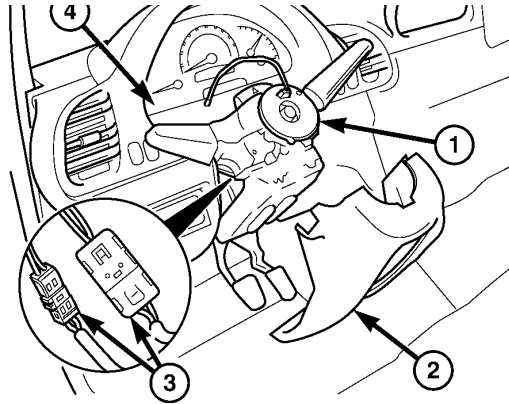

- 1 - CLOCKSPRING
- 2 - SHROUD
- 3 - CLOCKSPRING C1 & C2 CONNECTORS
- 4 - SRS INDICATOR

810fa02d

8.5 SEAT BELT TENSIONER

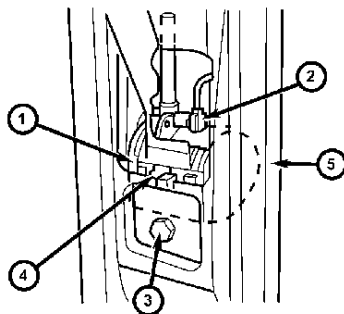

DRIVER AND PASSENGER

- 1- RETRACTOR
- 2 - CONNECTOR-SEATBELT TENSIONER
- 3 - SCREW
- 4 - GUIDE
- 5 - "B" PILLAR

810fa097

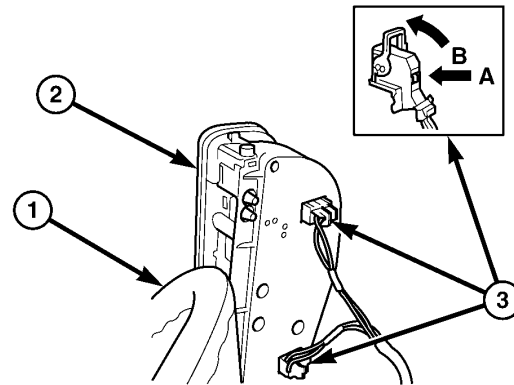

- 1 - STEERING WHEEL
- 2 - INSTRUMENT CLUSTER
- 3 - CONNECTOR C1 & C2

810fa11a

8.6 HEATING & A/C

8.6.1 AUTOMATIC TEMPERATURE CONTROL (ATC) SYSTEM COMPONENTS

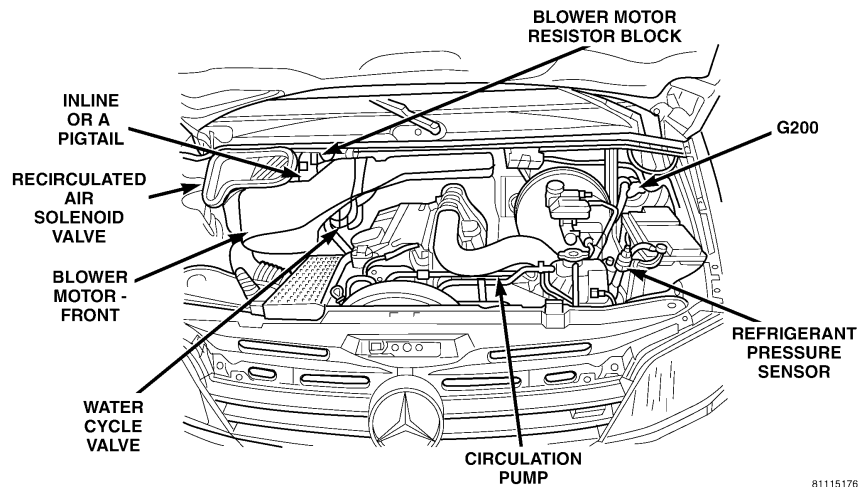

81115176

8.6.2 CABIN HEATER & HEATER BOOSTER SYSTEM COMPONENTS

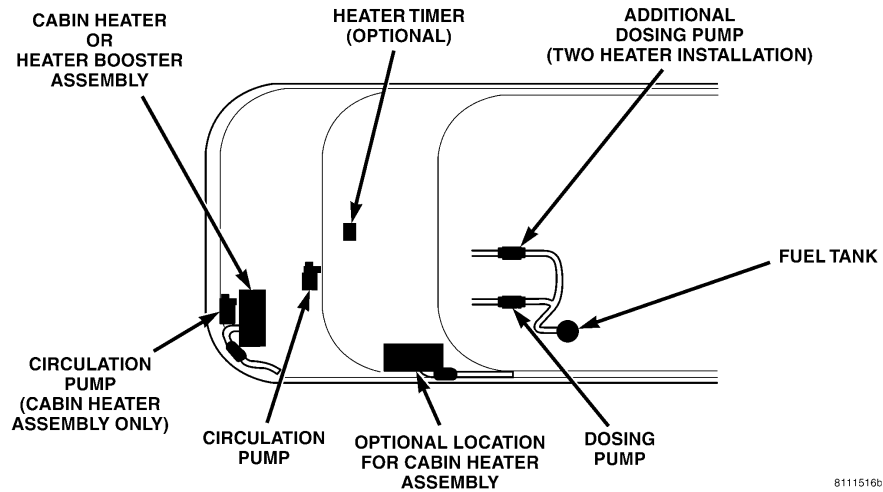

8.6.3 AUTO TEMP CONTROL, CABIN HEATER, & HEATER BOOSTER FUSES & RELAYS

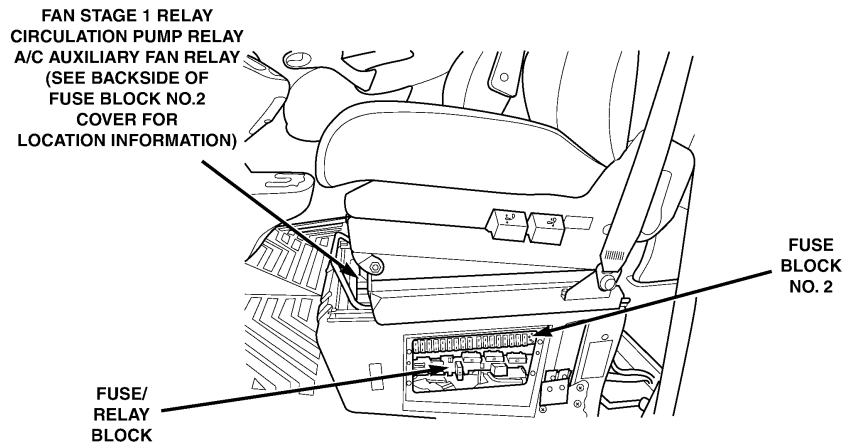

8.6.4 EVAP TEMP SENSOR & AIR OUTLET TEMP SENSOR

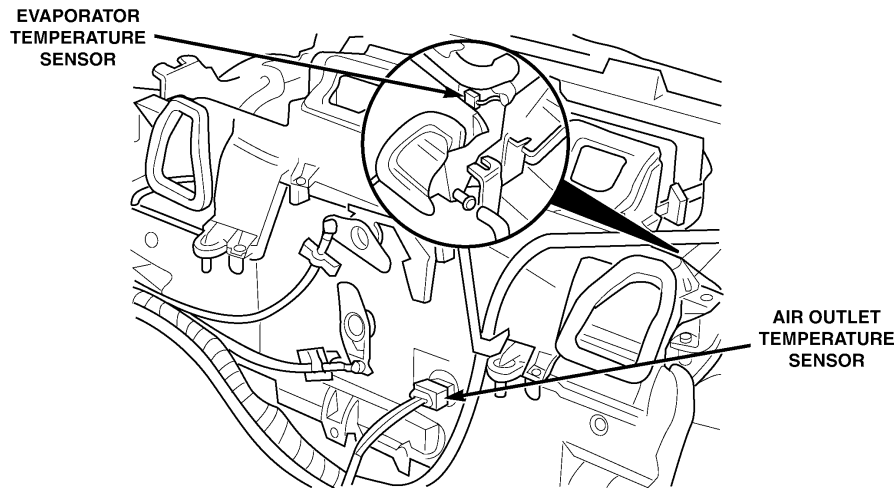

COMPONENT LOCATIONS

8.7 INSTRUMENT CLUSTER

8.7.1 AMBIENT TEMPERATURE SENSOR

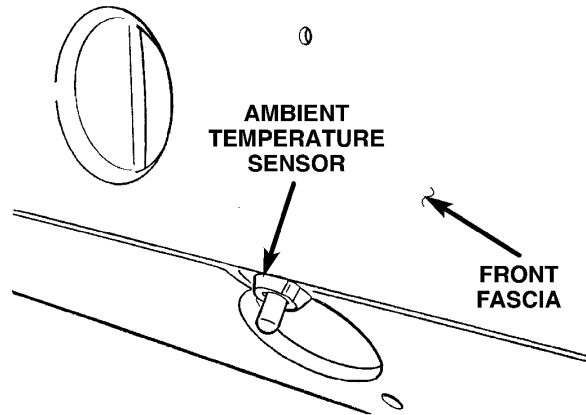

811b36e4

8.8 POWER DOOR LOCKS/RKE

8.8.1 CENTRAL TIMER MODULE

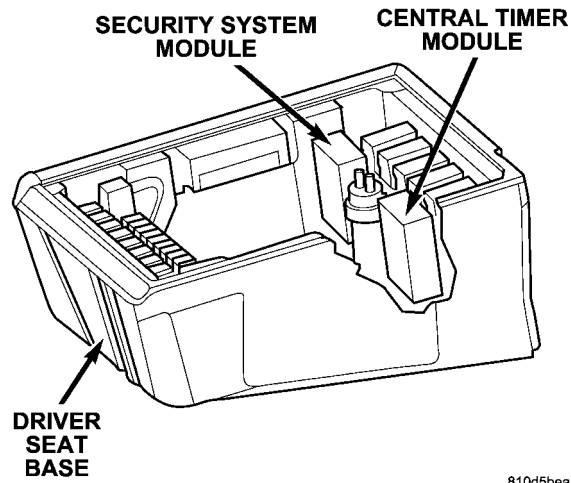

810d5bea

8.8.2 SENTRY KEY REMOTE ENTRY MODULE

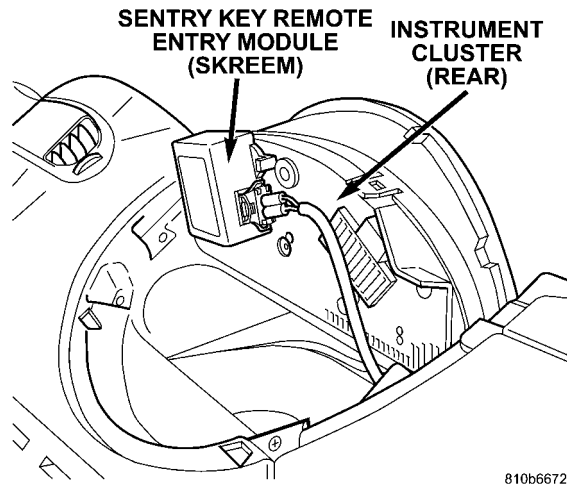

8.8.3 DOOR LOCK MOTOR/AJAR SWITCH

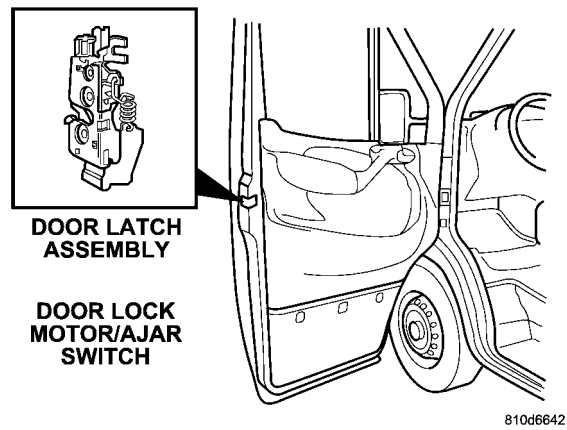

8.8.4 CONTACT PLATES

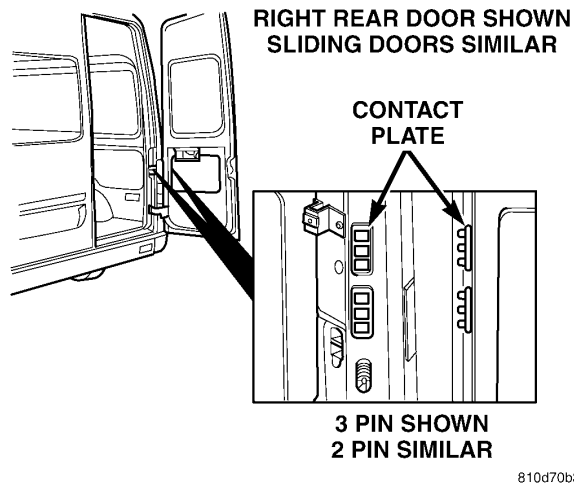

COMPONENT LOCATIONS

8.8 POWER DOOR LOCKS/RKE (Continued)

8.8.5 DOOR LOCK MOTOR/AJAR SWITCH CONNECTORS

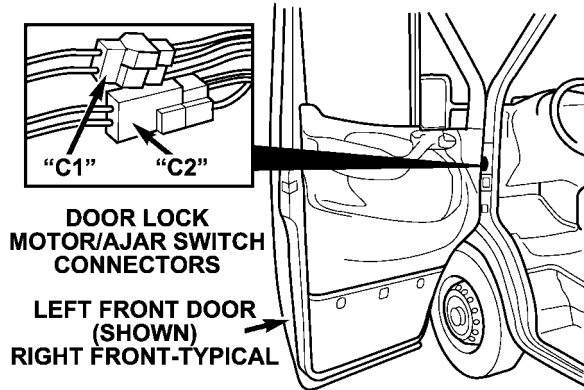

810d599e

8.9 VEHICLE THEFT SECURITY SYSTEM

8.9.1 SECURITY SYSTEM MODULE

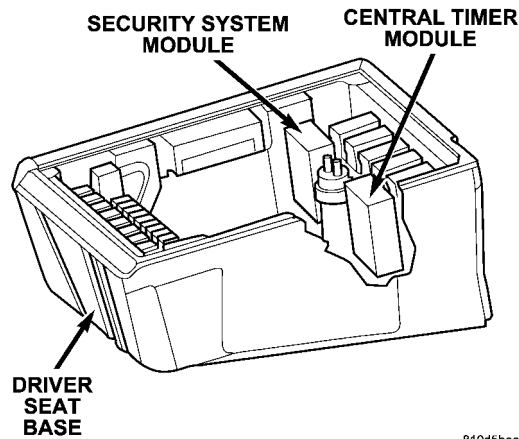

810d5bea

8.9.2 INTRUSION SENSORS

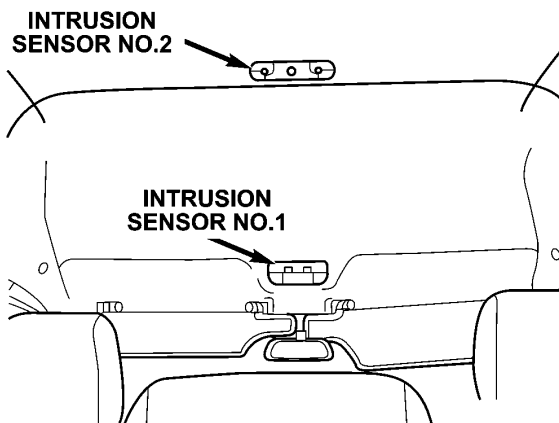

811135c8

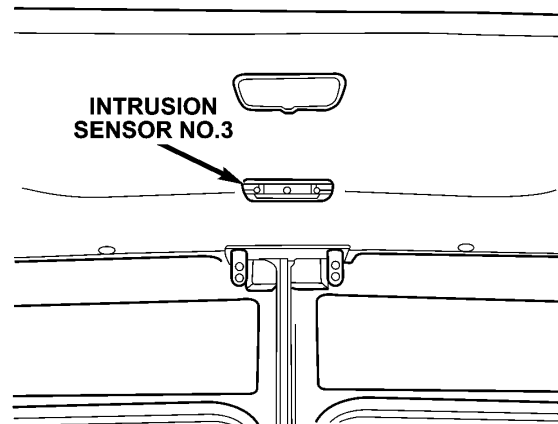

811135ce

8.9.3 SWITCHES

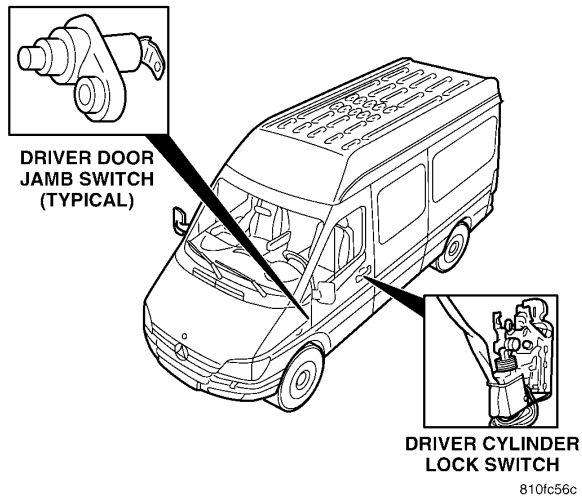

8.9.4 SIREN

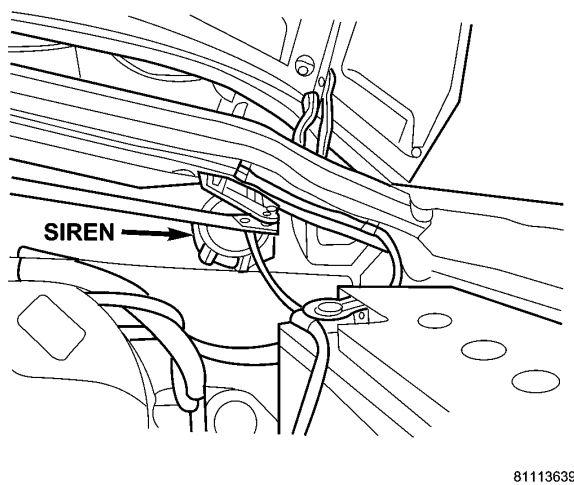

9.0 CONNECTOR PINOUTS

CONNECTOR
NOT
AVAILABLE

AIR OUTLET TEMPERATURE SENSOR		
CAV	CIRCUIT	FUNCTION
1	18BR/GY	AIR OUTLET TEMPERATURE SENSOR SIGNAL
2	18BR/BL	SENSOR GROUND

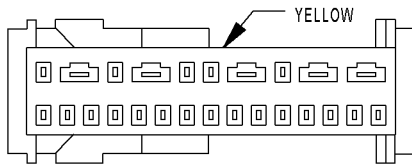

AIRBAG
CONTROL
MODULE

AIRBAG CONTROL MODULE - YELLOW		
CAV	CIRCUIT	FUNCTION
1	20BL	DRIVER SEAT BELT TENSIONER LINE 2
2	20BR/YL	DRIVER SEAT BELT TENSIONER LINE 1
3	20BL	PASSENGER SEAT BELT TENSIONER LINE 2
4	20BR	PASSENGER SEAT BELT TENSIONER LINE 1
5	20BK	FUSED IGNITION SWITCH OUTPUT (RUN-START)
6	20BR	GROUND
7	20YL	AIRBAG WARNING INDICATOR DRIVER
9	20BK/RD	K-ACM
10	20DG	DRIVER AIRBAG SQUIB 1 LINE 2
11	20VT	DRIVER AIRBAG SQUIB 1 LINE 1
13	20BL/DG	PASSENGER AIRBAG SQUIB 1 LINE 2
14	20BR/DG	PASSENGER AIRBAG SQUIB 1 LINE 1
20	20DG	ENHANCED ACCIDENT REPORT DRIVER

CONNECTOR
NOT
AVAILABLE

AIRBAG SQUIB-DRIVER		
CAV	CIRCUIT	FUNCTION
1	20DG	DRIVER AIRBAG SQUIB 1 LINE 2
2	20VT	DRIVER AIRBAG SQUIB 1 LINE 1

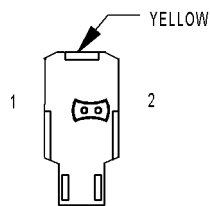

AIRBAG
SQUIB-PASSENGER

AIRBAG SQUIB-PASSENGER - YELLOW		
CAV	CIRCUIT	FUNCTION
1	20BL/DG	PASSENGER AIRBAG SQUIB 1 LINE 2
2	20BR/DG	PASSENGER AIRBAG SQUIB 1 LINE 1

CONNECTOR PINOUTS

CONNECTOR
NOT
AVAILABLE

AMBIENT TEMPERATURE SENSOR

CAV	CIRCUIT	FUNCTION
1	20BL/DG	AMBIENT TEMPERATURE SENSOR SIGNAL (+)
2	20BR/DG	AMBIENT TEMPERATURE SENSOR SIGNAL RETURN

CONNECTOR
NOT
AVAILABLE

AUXILIARY HEATER SWITCH

CAV	CIRCUIT	FUNCTION
1	16GY/DG/RD	DAYTIME RUNNING LAMP RELAY OUTPUT
3	16RD/YL	FUSED B(+)
7	16YL	CABIN HEATER CONTROL
10	16BR	GROUND

CONNECTOR
NOT
AVAILABLE

BLOWER MOTOR RESISTOR BLOCK

CAV	CIRCUIT	FUNCTION
1	12YL/BK	BLOWER MOTOR M2 DRIVER
2	12YL	BLOWER MOTOR LOW DRIVER
3	12BK/WT	BLOWER MOTOR M1 DRIVER
4	12DG	BLOWER MOTOR HIGH DRIVER

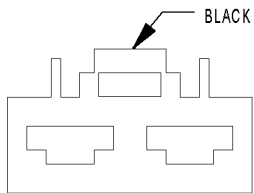

BLOWER
MOTOR-
FRONT

BLOWER MOTOR-FRONT - BLACK

CAV	CIRCUIT	FUNCTION
1	12RD/BL	BLOWER MOTOR HIGH DRIVER
2	12BK	GROUND

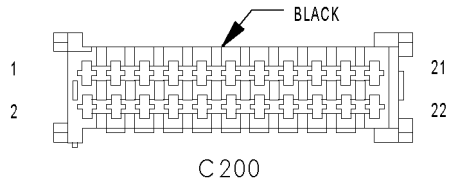

C200 - BLACK (DASH SIDE)

CAV	CIRCUIT
1	16GY
2	16GY/DG
3	16BK/YL
4	16DG/BL/WT
5	16YL/BL
6	16BL/RD
7	16BK/RD
8	16WT/BK
9	16WT/DG
10	16WT/YL
11	16WT/RD
12	16BK/RD
13	16VT/YL
14	16BR/WT
15	16YL
16	16BR/WT
17	16GY/RD
18	16BK/YL/DG
19	16BK/YL

C200 - BLACK (MAIN BODY SIDE)

CAV	CIRCUIT
1	16GY
2	16GY/DG
3	16BK/YL
4	16DG/BL/WT
5	16YL/BL
6	16BL/RD
7	16BK/RD
8	16WT/BK
9	16WT/DG
10	16WT/YL
11	16WT/RD
12	16BK/RD
13	18VT/YL
14	16BR/BK
15	16YL
16	16BR/WT
17	16GY/RD
18	16BK/YL/DG
19	16BK/YL

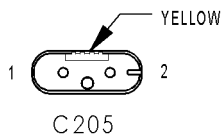
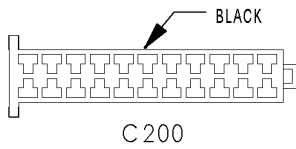

C205 - YELLOW (DASH SIDE)

CAV	CIRCUIT
1	20BL/DG
2	20BR/DG

CONNECTOR PINOUTS

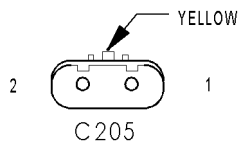

C205 - YELLOW (MAIN BODY SIDE)

CAV	CIRCUIT
1	20BL/DG
2	20BR/DG

CONNECTOR
NOT
AVAILABLE

C219 - (MAIN BODY SIDE)

CAV	CIRCUIT
5	16BK/RD
6	16BL/RD
7	16YL/WT
8	16DG/BK
9	16BK/RD
10	16BL/RD
11	16YL/RD
12	16DG/YL

C219 - BLACK (CABIN SIDE)

CAV	CIRCUIT
5	16BK/RD
6	16BL/RD
7	16YL/WT
8	16DG/BK
9	16BK/RD
10	16BL/RD
11	16YL/RD
12	16DG/YL

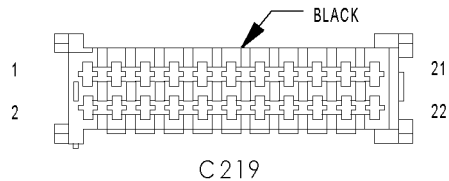

CENTRAL TIMER MODULE C1 - PINK

CAV	CIRCUIT	FUNCTION
1	16DG/BK	DRIVER DOOR UNLOCK SENSE
2	16BL/RD	DRIVER DOOR LOCK DRIVER
3	16BK/RD	DRIVER DOOR UNLOCK DRIVER
4	16YL/BK	DRIVER DOOR LOCK SENSE
5	16DG/BL/WT	PASSENGER FRONT DOOR UNLOCK SENSE
6	16YL/BL	PASSENGER FRONT DOOR LOCK SENSE
7	18BK/YL	MASTER DOOR LOCK SWITCH SENSE-ALL DOORS
8	16RD/BK	FUSED D(+) RELAY NO. 1 OUTPUT
9	16WT/BL (EXCEPT VTSS)	RKE INTERFACE
9	16WT/BL/RD (VTSS)	RKE INTERFACE
10	16BK/RD	FUSED IGNITION SWITCH OUTPUT
11	16DG	ENHANCED ACCIDENT REPORT DRIVER
12	20DG/WT	K-CTM/SSM
13	14RD/WT	FUSED B(+)
14	14BR	GROUND
15	16WT/BK	DRIVER DOOR AJAR INDICATOR DRIVER

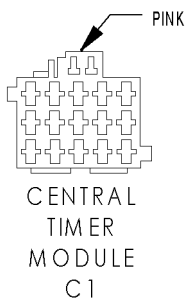

CONNECTOR PINOUTS

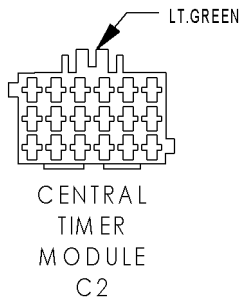

CENTRAL TIMER MODULE C2 - LT.GREEN

CAV	CIRCUIT	FUNCTION
3	16WT/DG	PASSENGER DOOR AJAR INDICATOR DRIVER
6	16WT/RD	MASTER DOOR LOCK SWITCH SENSE-PASSENGER DOORS
7	16DG/BK	LEFT SLIDING DOOR UNLOCK SENSE
10	16DG/RD	REAR DOOR UNLOCK SENSE
11	16YL/WT	LEFT SLIDING DOOR LOCK SENSE
12	16YL/BK	REAR DOOR LOCK SENSE
13	16YL/RD	RIGHT SLIDING DOOR LOCK SENSE
14	16DG/YL	RIGHT SLIDING DOOR UNLOCK SENSE
17	16BK/RD	PASSENGER DOORS UNLOCK DRIVER (+)
18	16BL/RD	PASSENGER DOORS LOCK DRIVER (+)

CONNECTOR
NOT
AVAILABLE

CIRCULATION PUMP (CABIN HEATER MODULE)

CAV	CIRCUIT	FUNCTION
1	18DG/RD	CIRCULATION PUMP RELAY OUTPUT
2	18BR	GROUND

CONNECTOR
NOT
AVAILABLE

CIRCULATION PUMP (REST SYSTEM)

CAV	CIRCUIT	FUNCTION
1	18DG/RD	CIRCULATION PUMP CONTROL
2	18BR	GROUND

CONNECTOR
NOT
AVAILABLE

CLOCKSPRING C2

CAV	CIRCUIT	FUNCTION
1	20VT	DRIVER AIRBAG SQUIB 1 LINE 1
2	20DG	DRIVER AIRBAG SQUIB 1 LINE 2

CONNECTOR PINOUTS

CONNECTOR PINOUTS

CONNECTOR
NOT
AVAILABLE

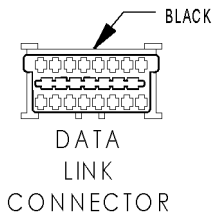
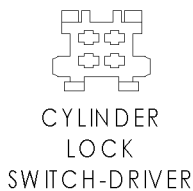

CONNECTOR
NOT
AVAILABLE

CONTROLLER ANTILOCK BRAKE

CAV	CIRCUIT	FUNCTION
1	12BR	GROUND
2	12RD	FUSED B(+)
5	14BR	GROUND
6	14RD	FUSED B(+)
11	18BL/BK	K-ABS/SHIFTER ASSEMBLY
12	18BK	LEFT FRONT WHEEL SPEED SENSOR (+)
14	20WT	LEFT REAR WHEEL SPEED SENSOR (+)
15	18BR	RIGHT FRONT WHEEL SPEED SENSOR(-)
16	18BK	RIGHT FRONT WHEEL SPEED SENSOR (+)
20	20WT	BRAKE SWITCH OUTPUT
23	18BK/RD	FUSED OPTIONAL EQUIPMENT RELAY OUTPUT
24	20DG/WT	CAN C BUS (+)
27	18BK/BL	TCS SWITCH (ASR) SENSE
28	18BR	LEFT FRONT WHEEL SPEED SENSOR (-)
29	20BR	LEFT REAR WHEEL SPEED SENSOR (-)
30	20BR	RIGHT REAR WHEEL SPEED SENSOR (-)
31	20YL	RIGHT REAR WHEEL SPEED SENSOR (+)
32	18BK/RD	BRAKE LAMP SWITCH OUTPUT
40	20DG	CAN C BUS (-)

CYLINDER LOCK SWITCH-DRIVER

CAV	CIRCUIT	FUNCTION
1	16BK	DRIVER CYLINDER UNLOCK SENSE
3	16BR	GROUND
4	16RD	DRIVER CYLINDER LOCK SENSE

DATA LINK CONNECTOR - BLACK

CAV	CIRCUIT	FUNCTION
1	20WT/DG	K-SKREEM
3	20DG/GY	ENGINE RPM
4	20BR	GROUND
5	20BR	GROUND
7	18BL/YL	K-ECM
8	20BK/BL/DG	FUSED IGNITION SWITCH OUTPUT (RUN-START)
9	20BL/BK	K-ABS/SHIFTER ASSEMBLY
11	20BL	K-TCM
12	20GY/DG/RD	K-CTM/SSM
13	20BK/RD	K-ACM
15	20WT/GY	K-IC/ATC/HBM/CHM
16	20RD/YL	FUSED B(+)

DOOR LOCK MOTOR/AJAR SWITCH ASSEMBLY-DRIVER C1

CAV	CIRCUIT	FUNCTION
1	16YL/BK	DRIVER DOOR LOCK SENSE
2	16DG/BK	DRIVER DOOR UNLOCK SENSE

CONNECTOR
NOT
AVAILABLE

DOOR LOCK MOTOR/AJAR SWITCH ASSEMBLY-DRIVER C2

CAV	CIRCUIT	FUNCTION
1	16BK/RD	DRIVER DOOR UNLOCK DRIVER
2	16BL/RD	DRIVER DOOR LOCK DRIVER

CONNECTOR
NOT
AVAILABLE

DOOR LOCK MOTOR/AJAR SWITCH ASSEMBLY-LEFT SLIDING C1

CAV	CIRCUIT	FUNCTION
1	16BK/RD	PASSENGER DOORS UNLOCK DRIVER (+)
2	16BL/RD	PASSENGER DOORS LOCK DRIVER (+)

CONNECTOR
NOT
AVAILABLE

DOOR LOCK MOTOR/AJAR SWITCH ASSEMBLY-LEFT SLIDING C2

CAV	CIRCUIT	FUNCTION
3	16YL/WT	LEFT SLIDING DOOR LOCK SENSE
4	16DG/BK	LEFT SLIDING DOOR UNLOCK SENSE

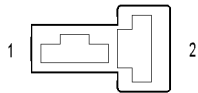

DOOR LOCK
MOTOR/AJAR
SWITCH
ASSEMBLY-
PASSENGER C1

DOOR LOCK MOTOR/AJAR SWITCH ASSEMBLY-PASSENGER C1

CAV	CIRCUIT	FUNCTION
1	20YL/BL	PASSENGER FRONT DOOR LOCK SENSE
2	20DG/BL/WT	PASSENGER FRONT DOOR UNLOCK SENSE

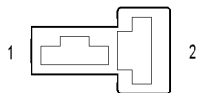

DOOR LOCK
MOTOR/AJAR
SWITCH
ASSEMBLY-
PASSENGER C2

DOOR LOCK MOTOR/AJAR SWITCH ASSEMBLY-PASSENGER C2

CAV	CIRCUIT	FUNCTION
1	16BK/RD	PASSENGER DOORS UNLOCK DRIVER (+)
2	16BL/RD	PASSENGER DOORS LOCK DRIVER (+)

CONNECTOR PINOUTS

CONNECTOR
NOT
AVAILABLE

DOOR LOCK MOTOR/AJAR SWITCH ASSEMBLY-REAR C1		
CAV	CIRCUIT	FUNCTION
1	16BK/RD	PASSENGER DOORS UNLOCK DRIVER (+)
2	16BL/RD	PASSENGER DOORS LOCK DRIVER (+)

CONNECTOR
NOT
AVAILABLE

DOOR LOCK MOTOR/AJAR SWITCH ASSEMBLY-REAR C2		
CAV	CIRCUIT	FUNCTION
3	16YL/BK (CARGO VAN)	REAR DOOR LOCK SENSE
4	16DG/RD (CARGO VAN)	REAR DOOR UNLOCK SENSE
4	16YLBK (PASSENGER VAN)	REAR DOOR LOCK SENSE
5	16DG/RD (PASSENGER VAN)	REAR DOOR UNLOCK SENSE

CONNECTOR
NOT
AVAILABLE

DOOR LOCK MOTOR/AJAR SWITCH ASSEMBLY-RIGHT SLIDING C1		
CAV	CIRCUIT	FUNCTION
1	16BK/RD	PASSENGER DOORS UNLOCK DRIVER (+)
2	16BL/RD	PASSENGER DOORS LOCK DRIVER (+)

CONNECTOR
NOT
AVAILABLE

DOOR LOCK MOTOR/AJAR SWITCH ASSEMBLY-RIGHT SLIDING C2		
CAV	CIRCUIT	FUNCTION
3	16YL/RD	RIGHT SLIDING DOOR LOCK SENSE
4	16DG/YL	RIGHT SLIDING DOOR UNLOCK SENSE

CONNECTOR
NOT
AVAILABLE

DOSING PUMP		
CAV	CIRCUIT	FUNCTION
1	16DG	DOSING PUMP CONTROL
2	16BR	GROUND

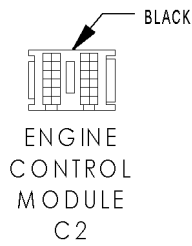

ENGINE CONTROL MODULE C2 - BLACK

CAV	CIRCUIT	FUNCTION
7	18BR/DG	KICKDOWN SWITCH SIGNAL
9	18BR	SENSOR GROUND
11	20DG/WT	CAN C BUS (+)
12	20DG	CAN C BUS (-)
13	18BK	FUSED IGNITION SWITCH OUTPUT (RUN-START)
14	18DG	ACCEL/SET SIGNAL
16	18YL	DECEL/SET SIGNAL
17	20DG	ENHANCED ACCIDENT REPORT DRIVER
19	18RD	S/C SWITCH 12 VOLT SUPPLY
20	18BL	RESUME SIGNAL
21	18BK	VERIFICATION SIGNAL
22	18GY	OFF SIGNAL

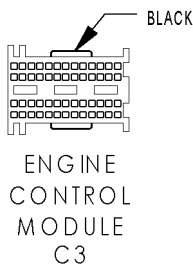

ENGINE CONTROL MODULE C3 - BLACK

CAV	CIRCUIT	FUNCTION
1	18BR/DG	INTAKE AIR TEMPERATURE SENSOR GROUND
5	18BL/RD	ACCEL PEDAL POSITION SENSOR 5 VOLT SUPPLY
6	18WT/DG	BOOST PRESSURE SENSOR SIGNAL
7	20BR/YL	MASS AIR FLOW SENSOR GROUND
8	18BR/GY	ACCEL PEDAL POSITION SENSOR GROUND NO. 2
9	18GY/DG	ACCEL PEDAL POSITION SENSOR SIGNAL NO. 2
10	18BL/DG	ACCEL PEDAL POSITION SENSOR SIGNAL NO. 1
12	18DG/WT	INTAKE AIR TEMPERATURE SENSOR SIGNAL
17	18WT/RD	BOOST PRESSURE SENSOR 5 VOLT SUPPLY
18	20YL/DG	MASS AIR FLOW SENSOR SIGNAL
19	20BR/BK	MASS AIR FLOW SENSOR 5 VOLT SUPPLY
20	18VT	IGNITION SWITCH OUTPUT (START)
22	18BR/WT	BOOST PRESSURE SENSOR GROUND
23	18BR/BL	ACCEL PEDAL POSITION SENSOR GROUND NO. 1
25	18BK/RD	GLOW PLUG MODULE CONTROL
28	20BL/YL	K-ECM
30	18RD/BL	STARTER MOTOR RELAY 12 VOLT SUPPLY
33	20YL/RD	MASS AIR FLOW SENSOR 12 VOLT SUPPLY
35	20BR	BOOST PRESSURE SOLENOID 12 VOLT SUPPLY
40	20DG/YL	ENGINE RPM
43	18VT/DG	STARTER MOTOR RELAY CONTROL
46	18YL/BL	ENGINE CONTROL RELAY SIGNAL
48	20WT	BOOST PRESSURE SOLENOID CONTROL

CONNECTOR NOT AVAILABLE

EVAPORATOR TEMPERATURE SENSOR

CAV	CIRCUIT	FUNCTION
1	18BR/DG	EVAPORATOR TEMPERATURE SENSOR SIGNAL
2	18BR/BL	SENSOR GROUND

CONNECTOR PINOUTS

CONNECTOR
NOT
AVAILABLE

FUEL LEVEL SENSOR

CAV	CIRCUIT	FUNCTION
2	20BL/BK	FUEL LEVEL SENSOR SIGNAL (+)
3	20BR	FUEL LEVEL SENSOR SIGNAL RETURN

CONNECTOR
NOT
AVAILABLE

FUSE BLOCK NO. 1 C2

CAV	CIRCUIT	FUNCTION
1	14BK/RD	FUSED IGNITION SWITCH OUTPUT (RUN)
2	14BK/YL	FUSED IGNITION SWITCH OUTPUT (START)
3	16GY/DG	FUSED IGNITION SWITCH OUTPUT (ACC OFF)
4	14BK	FUSED IGNITION SWITCH OUTPUT (RUN-START)

FUSE BLOCK NO. 1

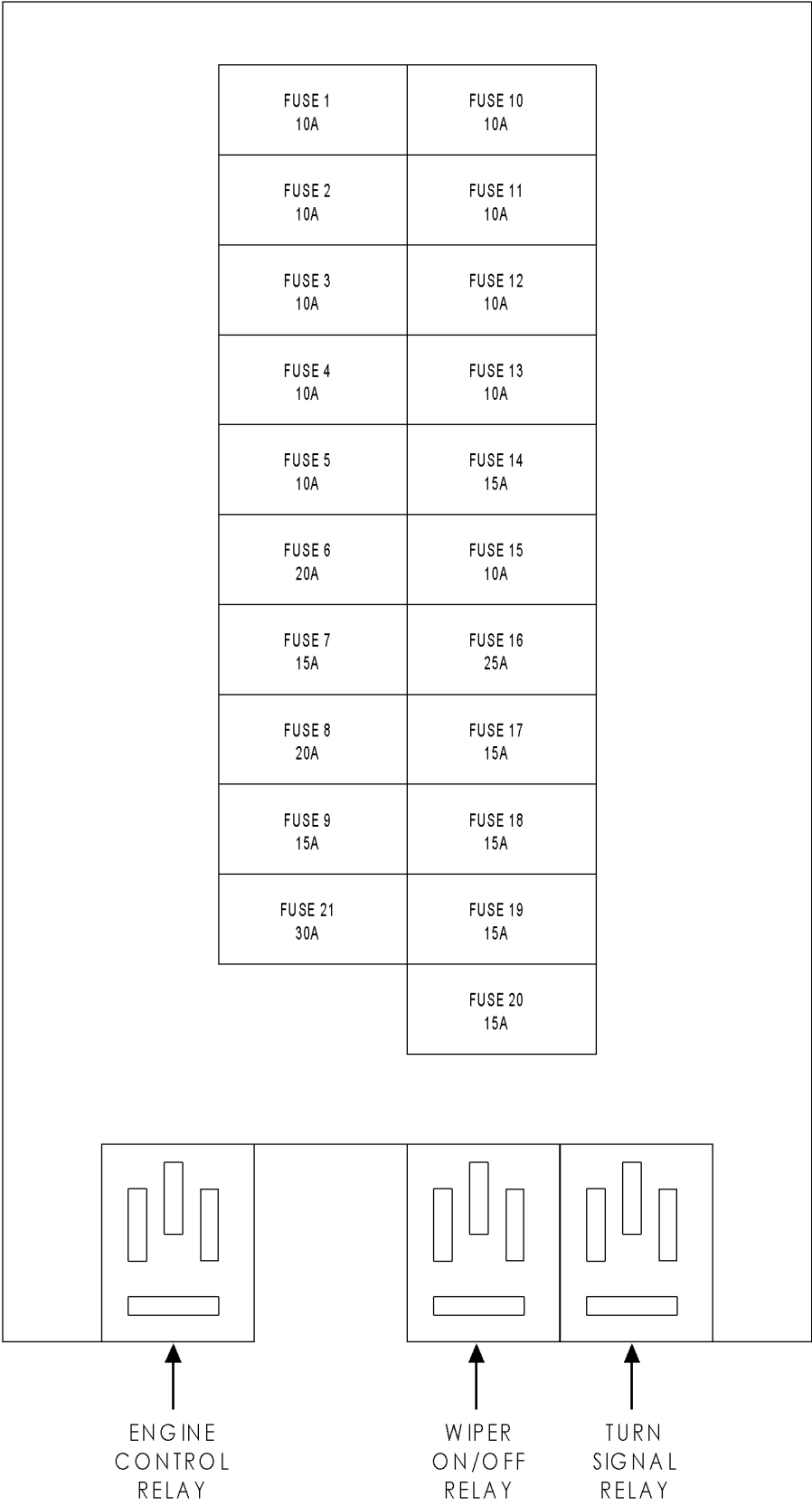

CONNECTOR PINOUTS

NOTE: THE FUSE AND RELAY LOCATIONS SHOWN HERE MAY VARY FROM VEHICLE TO VEHICLE.

CONNECTOR PINOUTS

FUSES (FUSE BLOCK NO. 1)

CAV	CIRCUIT	FUNCTION
1	16GY/RD	FUSED B(+)
2	16WT	FUSED HIGH BEAM SWITCH OUTPUT
3	16WT	FUSED HIGH BEAM SWITCH OUTPUT
4	16BK/BL	FUSED IGNITION SWITCH OUTPUT (RUN-START)
5	16BK/BL/WT	FUSED IGNITION SWITCH OUTPUT (RUN-START)
6	INTERNAL	FUSED IGNITION SWITCH OUTPUT (RUN-START)
7	16BK/YL	FUSED IGNITION SWITCH OUTPUT (RUN-START)
8	16RD/YL	FUSED IGNITION SWITCH OUTPUT (RUN-START)
9	-	-
10	16GY/DG/RD	HEADLAMP SWITCH OUTPUT
11	16GY/BK	FUSED B(+)
12	18YL	HEADLAMP SWITCH OUTPUT
13	18YL	HEADLAMP SWITCH OUTPUT
14	16BK/YL/WT	FOG LAMP RELAY SIGNAL
15	16BK/RD	FUSED IGNITION SWITCH OUTPUT (ACC-RUN-START)
16	16BK/RD	ENGINE CONTROL RELAY OUTPUT
17	16BK/RD	ENGINE CONTROL RELAY OUTPUT
18	14BK	FUSED IGNITION SWITCH OUTPUT (RUN-START)
19	-	FUSED B(+)
20	16RD/BL	FUSED B(+)
21	12RD	FUSED B(+)

FUSES (FUSE BLOCK NO. 2)

CAV	CIRCUIT	FUNCTION
1	16RD/GY	FUSED B(+)
2	16RD	FUSED B(+)
3	16RD	FUSED B(+)
4	16RD/YL	FUSED B(+)
5	14RD/WT	FUSED B(+)
6	18RD/YL	FUSED B(+)
7	16BK/YL	OPTIONAL EQUIPMENT RELAY OUTPUT
8	16WT/RD	OPTIONAL EQUIPMENT RELAY OUTPUT
9	16RD/BK/WT	FUSED D(+) RELAY NO. 1 OUTPUT
10	16RD/YL/WT	FUSED D(+) RELAY NO. 1 OUTPUT
11	16RD/YL/WT	FUSED D(+) RELAY NO. 1 OUTPUT
12	14RD	FUSED B(+)
13	14RD	FUSED B(+)
14	14RD	FUSED B(+)
15	16BK/YL	OPTIONAL EQUIPMENT RELAY OUTPUT

FUSES (FUSE BLOCK NO. 3)

CAV	CIRCUIT	FUNCTION
1	16RD	FUSED B(+)
2	16RD/DG	FUSED B(+)
3	12RD/DG	FUSED B(+)
4	14RD	FUSED B(+)
5	16RD	FUSED B(+)
6	14RD	FUSE B(+)
7	16BK	OPTIONAL EQUIPMENT RELAY OUTPUT
8	12RD/WT	FUSED B(+)
9	16RD/BK/WT	FUSED B(+)
10	16RD/GY	FUSED B(+)
11	14RD	FUSED B(+)
12	10BK	OPTIONAL EQUIPMENT RELAY OUTPUT
13	18BK/YL	OPTIONAL EQUIPMENT RELAY OUTPUT
14	16BK/GY	OPTIONAL EQUIPMENT RELAY OUTPUT
15	16VT/YL	OPTIONAL EQUIPMENT RELAY OUTPUT
18	16RD/YL	FUSED B(+)
19	16RD/DG/VT	FUSED D(+) RELAY NO. 1 OUTPUT
20	16BK/YL	OPTIONAL EQUIPMENT RELAY OUTPUT

FUSES (FUSE/RELAY BLOCK)

FUSE NO.	AMPS	FUSED CIRCUIT	FUNCTION
1	30A	14BL/YL	FUSED B(+)
5	10A	16RD/YL	FUSED B(+)
6	7.5A	18BK/RD	OPTIONAL EQUIPMENT RELAY OUTPUT
7	25A	14RD	FUSED B(+)
8	40A	12RD	FUSED B(+)
9	40A	12RD	FUSED B(+)
10	30A	12RD/GY	FUSED B(+)

CONNECTOR PINOUTS

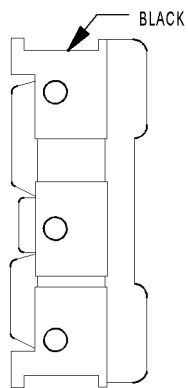

HOOD AJAR SWITCH

HOOD AJAR SWITCH - BLACK

CAV	CIRCUIT	FUNCTION
1	16BK/BL	HOOD AJAR SWITCH SENSE
3	16BR	GROUND

CONNECTOR NOT AVAILABLE

INSTRUMENT CLUSTER C1

CAV	CIRCUIT	FUNCTION
1	20BR	FUEL LEVEL SENSOR SIGNAL RETURN
2	20BR/DG	AMBIENT TEMPERATURE SENSOR SIGNAL RETURN
4	20WT/GY	K-IC/ATC/HBM/CHM
5	20BR/BK	BRAKE INDICATOR SIGNAL
7	20BK/DG	RIGHT TURN SIGNAL
10	20BL/BK	FUEL LEVEL SENSOR SIGNAL (+)
11	20BL/DG	AMBIENT TEMPERATURE SENSOR SIGNAL (+)
14	20DG/WT/BL	ENGINE COOLANT LEVEL SWITCH SIGNAL
15	20BR/WT	FRONT COURTESY LAMPS CONTROL
16	20YL/RD	SEAT BELT SWITCH SIGNAL
17	20DG	CAN C BUS (-)
18	20DG/WT	CAN C BUS (+)

INSTRUMENT CLUSTER C2 - WHITE

CAV	CIRCUIT	FUNCTION
3	20RD/YL	FUSED B(+)
4	20BR/WT	BRAKE WEAR SENSOR SIGNAL
6	18BR	GROUND
7	20GY/DG/RD	LAMP DRIVER
8	20BL/WT	FUSED HIGH BEAM SWITCH OUTPUT
9	20BL/RD/WT	VEHICLE SPEED SENSOR OUTPUT
10	20BK	FUSED IGNITION SWITCH OUTPUT (RUN-START)
11	20BL/BK	KEY-IN IGNITION SWITCH SIGNAL
13	20BK/WT	LEFT TURN SIGNAL
15	20BL	TERMINAL 61
16	20YL	AIRBAG WARNING INDICATOR DRIVER
18	20BL/VT	D(+) RELAY NO. 1 CONTROL
18	20BL/VT	IC 18-C2 TO ATCM 8-C1

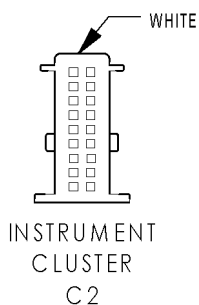

INSTRUMENT CLUSTER C2

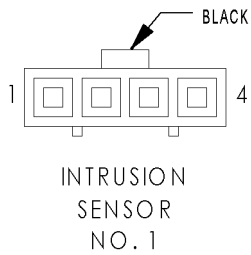

INTRUSION SENSOR NO. 1 - BLACK		
CAV	CIRCUIT	FUNCTION
1	20BR	GROUND
2	20DG/BK	INTRUSION SENSOR 1 SIGNAL
3	20DG/YL	INTRUSION SENSOR INTERFACE
4	20RD/DG	FUSED B(+)

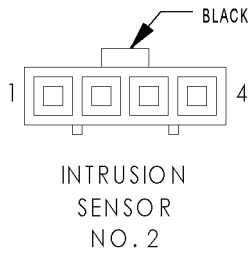

INTRUSION SENSOR NO. 2 - BLACK		
CAV	CIRCUIT	FUNCTION
1	20BR	GROUND
2	20GY/BK	INTRUSION SENSOR 2 SIGNAL
3	20DG/YL	INTRUSION SENSOR INTERFACE
4	20RD/DG	FUSED B(+)

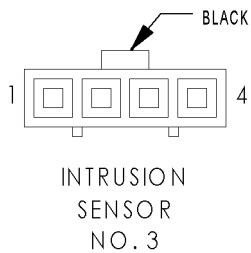

INTRUSION SENSOR NO. 3 - BLACK		
CAV	CIRCUIT	FUNCTION
1	20BR	GROUND
2	20DG/WT/BL	INTRUSION SENSOR 3 SIGNAL
3	20DG/YL	INTRUSION SENSOR INTERFACE
4	20RD/DG	FUSED B(+)

CONNECTOR
NOT
AVAILABLE

MASTER DOOR LOCK SWITCH		
CAV	CIRCUIT	FUNCTION
1	16GY/DG/RD	LAMP DRIVER
2	16WT/DG	PASSENGER DOOR AJAR INDICATOR DRIVER
3	16WT/YL	MASTER DOOR LOCK SWITCH SENSE-ALL DOORS
8	16WT/RD	MASTER DOOR LOCK SWITCH SENSE-PASSENGER DOORS
9	16WT/BK	DRIVER DOOR AJAR INDICATOR DRIVER
10	16BR	GROUND

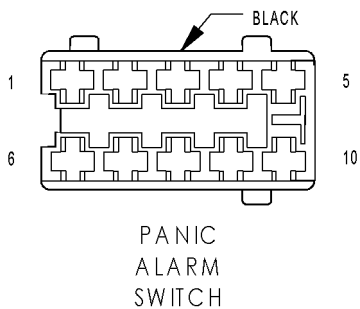

PANIC ALARM SWITCH - BLACK		
CAV	CIRCUIT	FUNCTION
1	18GY/DG/RD	LAMP DRIVER
3	18BR	GROUND
7	18GY/WT	PANIC SWITCH SENSE
10	18BR	GROUND

CONNECTOR PINOUTS

CONNECTOR
NOT
AVAILABLE

RECIRCULATED AIR SOLENOID VALVE

CAV	CIRCUIT	FUNCTION
1	16RD	RECIRCULATED AIR SOLENOID VALVE CONTROL
2	16BK	GROUND

CONNECTOR
NOT
AVAILABLE

REFRIGERANT PRESSURE SENSOR

CAV	CIRCUIT	FUNCTION
1	18BR/BL	SENSOR GROUND
2	20BR/RD	REFRIGERANT PRESSURE SENSOR FEEDBACK
3	20RD/BL	5 VOLT SUPPLY

RELAY BLOCK

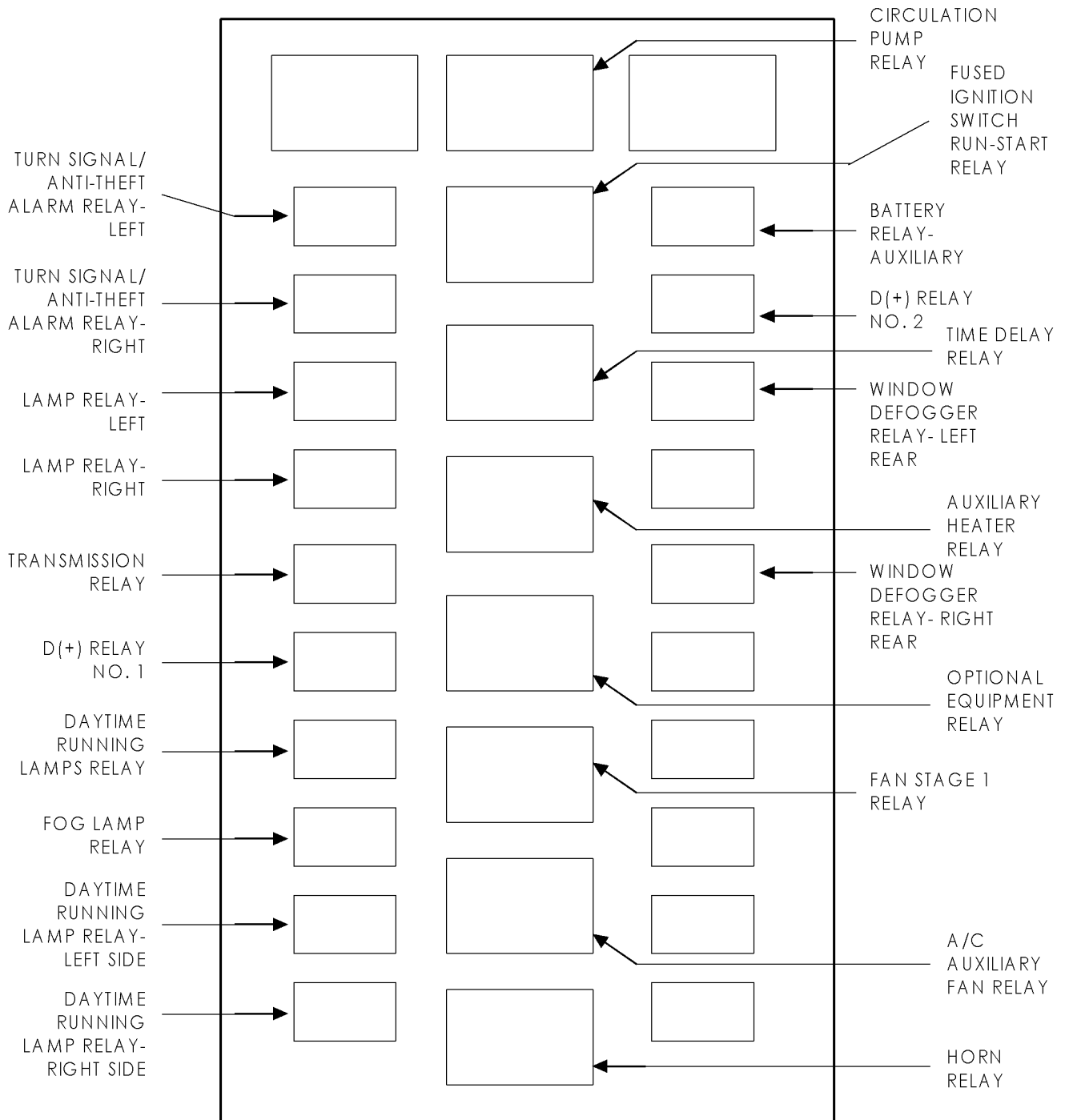

NOTE: THE RELAY LOCATIONS SHOWN HERE MAY VARY FROM VEHICLE TO VEHICLE.

CONNECTOR PINOUTS

A/C AUXILIARY FAN RELAY (IN RELAY BLOCK)

CAV	CIRCUIT	FUNCTION
30	14BL/YL	FUSED B(+)
85	18BR	GROUND
86	18BK/RD	A/C AUXILIARY FAN RELAY HIGH SIDE CONTROL
87	14DG/WT	A/C AUXILIARY FAN RELAY OUTPUT
87A	-	-

A/C AUXILIARY FAN

CAV	CIRCUIT	FUNCTION
1	14DG/BK	A/C AUXILIARY FAN RELAY OUTPUT
1	14DG/BL	A/C AUXILIARY FAN RELAY OUTPUT
2	14BR	GROUND

CIRCULATION PUMP RELAY (RELAY BLOCK)

CAV	CIRCUIT	FUNCTION
30	18DG/BK	CIRCULATION PUMP RELAY OUTPUT
85	16BR	GROUND
86	16BL/YL	CIRCULATION PUMP RELAY HIGH SIDE CONTROL
87	16RD/BL	FUSED B(+)
87A	16BK/YL	FUSED IGNITION SWITCH OUTPUT (RUN-START)

D(+) RELAY NO. 1 (RELAY BLOCK)

CAV	CIRCUIT	FUNCTION
30	10RD/YL	D(+) RELAY NO. 1 OUTPUT
85	16BR	GROUND
86	20BL/VT	D(+) RELAY NO. 1 CONTROL
87	10RD	FUSED B(+)
87A	16BR	GROUND

FAN STAGE 1 RELAY (RELAY BLOCK)

CAV	CIRCUIT	FUNCTION
30	14BK/VT	FAN STAGE 1 RELAY OUTPUT
85	16BR	GROUND
86	16BL/YL	FAN STAGE 1 RELAY HIGH SIDE CONTROL
87	16RD/WT	FUSED B(+)
87A	-	-

HORN RELAY - (RELAY BLOCK)

CAV	CIRCUIT	FUNCTION
30	16BR	GROUND
85	16BK/BL/VT	FUSED IGNITION SWITCH OUTPUT (RUN-START)
86	16BK/YL	HORN RELAY CONTROL
87	16BK/BR	HORN RELAY OUTPUT
87A	-	-

TURN SIGNAL/ANTI-THEFT ALARM RELAY-LEFT (RELAY BLOCK)

CAV	CIRCUIT	FUNCTION
30	16RD/YL	FUSED B(+)
85	18RD/YL	FUSED B(+)
86	18DG/YL	TURN SIGNAL/ANTI-THEFT ALARM RELAY-LEFT/RIGHT CONTROL
87	16BK/WT	LEFT TURN SIGNAL
87A	-	-

CONNECTOR PINOUTS

TURN SIGNAL/ANTI-THEFT ALARM RELAY-RIGHT (RELAY BLOCK)

CAV	CIRCUIT	FUNCTION
30	16RD/YL	FUSED B(+)
85	18RD/YL	FUSED B(+)
86	18DG/YL	TURN SIGNAL/ANTI-THEFT ALARM RELAY-LEFT/RIGHT CONTROL
87	16BK/DG	RIGHT TURN SIGNAL
87A	-	-

CONNECTOR PINOUTS

CONNECTOR
NOT
AVAILABLE

REMOTE KEYLESS ENTRY ANTENNA

CAV	CIRCUIT	FUNCTION
1	20BR	RKE ANTENNA
3	-	GROUND

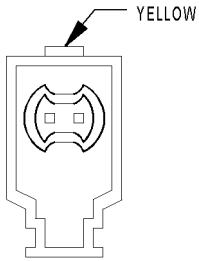

SEAT
BELT
TENSIONER-
DRIVER

SEAT BELT TENSIONER-DRIVER - YELLOW

CAV	CIRCUIT	FUNCTION
1	20BL	DRIVER SEAT BELT TENSIONER LINE 2
2	20BR/YL	DRIVER SEAT BELT TENSIONER LINE 1

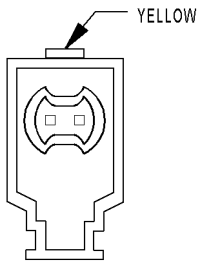

SEAT
BELT
TENSIONER-
PASSENGER

SEAT BELT TENSIONER-PASSENGER - YELLOW

CAV	CIRCUIT	FUNCTION
1	20BL	PASSENGER SEAT BELT TENSIONER LINE 2
2	20BR	PASSENGER SEAT BELT TENSIONER LINE 1

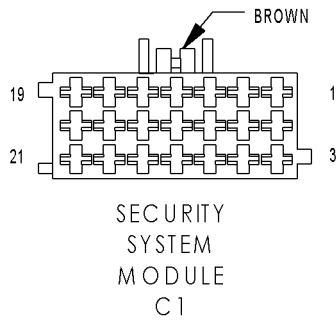

SECURITY SYSTEM MODULE C1 - BROWN

CAV	CIRCUIT	FUNCTION
1	16BK/WT	LEFT TURN SIGNAL
4	16BK/DG	RIGHT TURN SIGNAL
5	16BK/VT	FAN STAGE 1 RELAY
6	16WT/RD	WARM AIR AUXILIARY HEATER CONTROL
7	16RD/GY	FUSED B(+)
8	16BK/GY	FUSED OPTIONAL EQUIPMENT RELAY OUTPUT
9	18VT/DG	TOWING/INTRUSION SENSOR INDICATOR DRIVER
11	16BR/YL	FRONT COURTESY LAMPS CONTROL
12	16BR/WT	DOOR AJAR SWITCH SENSE
13	16RD/DG	FUSED B(+)
14	16BK/BL	HOOD AJAR SWITCH SENSE
15	18GY/WT	PANIC SWITCH SENSE
16	16BR	GROUND
17	18GY/BR	TOWING SENSOR SWITCH SENSE
18	18GY/YL	INTRUSION SENSOR SWITCH SENSE
20	16BK	DRIVER CYLINDER UNLOCK SENSE
21	16RD	DRIVER CYLINDER LOCK SENSE

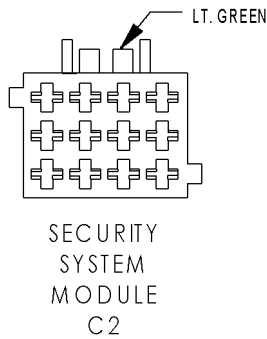

SECURITY SYSTEM MODULE C2 - LT.GREEN

CAV	CIRCUIT	FUNCTION
1	16DG/YL	INTRUSION SENSOR INTERFACE
2	16GY/BL	WINDOW DEFOGGER RELAY-LEFT REAR OUTPUT
3	16GY	WINDOW DEFOGGER RELAY-RIGHT REAR OUTPUT
4	20DG/BK	INTRUSION SENSOR 1 SIGNAL
7	20GY/BK	INTRUSION SENSOR 2 SIGNAL
8	20GY/DG	K-CTM/SSM
9	18BK/BL	SIREN SIGNAL CONTROL
10	20DG/WT/BL	INTRUSION SENSOR 3 SIGNAL
11	16WT/BL	RKE INTERFACE
12	16WT/BL/RD	SECURITY SYSTEM INTERFACE

CONNECTOR NOT AVAILABLE

SENTRY KEY REMOTE ENTRY MODULE (SKREEM)

CAV	CIRCUIT	FUNCTION
1	18YL	RKE ANTENNA
2	16BR	GROUND
3	16RD/YL	FUSED B(+)
4	16BK/WT	LEFT TURN SIGNAL
5	20DG/WT	CAN C BUS (+)
6	20DG	CAN C BUS (-)
7	16BK/YL	FUSED IGNITION SWITCH OUTPUT (RUN-START)
8	20WT/DG	K-SKREEM
9	20WT/BL/RD (EXCEPT VTSS)	RKE INTERFACE
9	20WT/BL/RD (VTSS)	SECURITY SYSTEM INTERFACE
10	18DG/YL	TURN SIGNAL/ANTI-THEFT ALARM RELAY-LEFT/RIGHT CONTROL
11	20BR	TRANSPONDER COIL (+)
12	20BR	TRANSPONDER COIL (-)

CONNECTOR PINOUTS

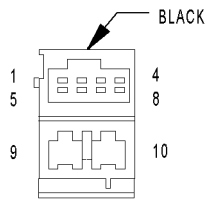

SHIFTER ASSEMBLY

SHIFTER ASSEMBLY - BLACK		
CAV	CIRCUIT	FUNCTION
2	20GY/DG/RD	LAMP DRIVER
3	20BL/DG	K-ABS/SHIFTER ASSEMBLY
4	18BR	GROUND
5	20BK/BL/RD	BRAKE LAMP SWITCH
6	20DG/WT	CAN C BUS (+)
7	20DG	CAN C BUS (-)
8	18BK/DG	TRANSMISSION RELAY OUTPUT
9	16WT/BL/RD	FUSED IGNITION SWITCH OUTPUT (RUN-START)
10	16WT/RD	BACK-UP LAMP

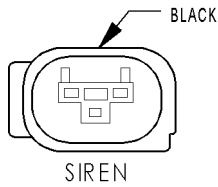

SIREN

SIREN - BLACK		
CAV	CIRCUIT	FUNCTION
1	18RD/DG	FUSED B(+)
2	18BR	GROUND
3	18BK/BL	SIREN SIGNAL CONTROL

CONNECTOR NOT AVAILABLE

TOWING/INTRUSION SENSOR ON/OFF SWITCH

CAV	CIRCUIT	FUNCTION
1	18GY/DG	LAMP DRIVER
3	18GY/YL	INTRUSION SENSOR SWITCH SENSE
4	18BR	GROUND
8	18GY/BR	TOWING SENSOR SWITCH SENSE
9	18VT/DG	TOWING/INTRUSION SENSOR INDICATOR DRIVER
10	18BR	GROUND

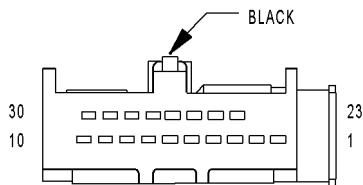

TRANSMISSION CONTROL MODULE C1

TRANSMISSION CONTROL MODULE C1 - BLACK		
CAV	CIRCUIT	FUNCTION
1	20BL	K-TCM
29	16BK/DG	TRANSMISSION RELAY OUTPUT
30	18BR	GROUND

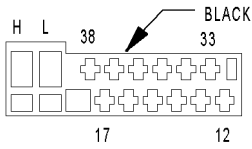

TRANSMISSION
CONTROL
MODULE C2

TRANSMISSION CONTROL MODULE C2 - BLACK

CAV	CIRCUIT	FUNCTION
12	20BL/GY	N2 INPUT SPEED SENSOR
13	20BK/BL	SENSOR SUPPLY VOLTAGE
14	16WT	1-2/4-5 SOLENOID CONTROL
15	16YL	3-4 SOLENOID CONTROL
16	16WT/BL	2-3 SOLENOID CONTROL
17	16YL/BL	TCC SOLENOID CONTROL
33	20PK	SENSOR GROUND
34	20GY/BL	TEMPERATURE SENSOR-P/N SWITCH
35	20BL/DG	N3 INPUT SPEED SENSOR
36	16BR/GY	MODULATION PRESSURE SOLENOID CONTROL
37	16BK/RD	SHIFT PRESSURE SOLENOID CONTROL
38	16BK	SOLENOID SUPPLY VOLTAGE
H	20DG/WT	CAN C BUS (+)
L	20DG	CAN C BUS (-)

CONNECTOR
NOT
AVAILABLE

WATER CYCLE VALVE

CAV	CIRCUIT	FUNCTION
1	18BR/VT	WATER CYCLE VALVE CONTROL
2	18BR	GROUND

CONNECTOR
NOT
AVAILABLE

WINDOW DEFOGGER-LEFT REAR

CAV	CIRCUIT	FUNCTION
1	16GY	WINDOW DEFOGGER RELAY-LEFT REAR OUTPUT
2	16BR	GROUND

CONNECTOR
NOT
AVAILABLE

WINDOW DEFOGGER-RIGHT REAR

CAV	CIRCUIT	FUNCTION
1	16GY	WINDOW DEFOGGER RELAY- RIGHT REAR OUTPUT
2	16BR	GROUND

10.0 SCHEMATIC DIAGRAMS

10.1 AIRBAG SYSTEM

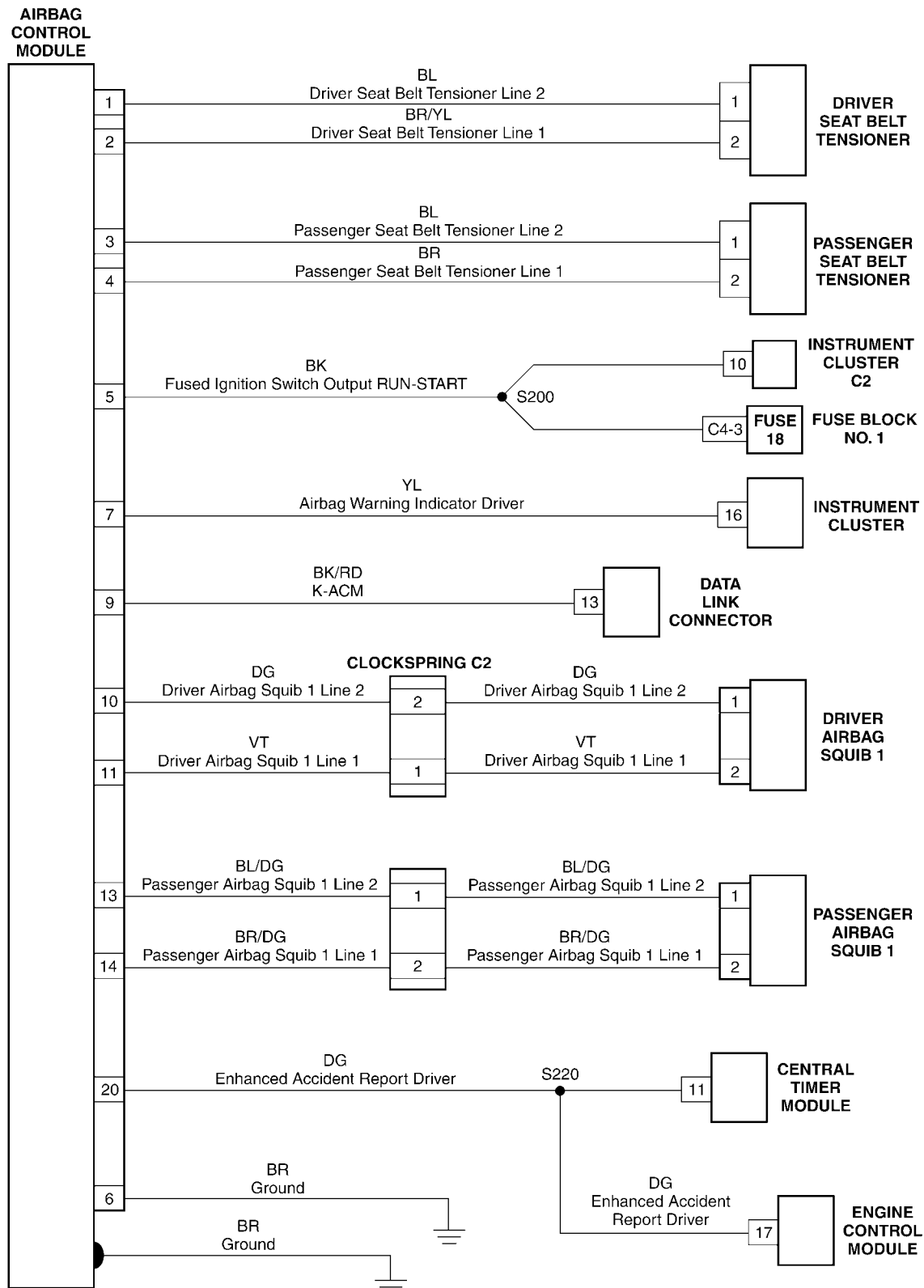

810f995e

SCHEMATIC DIAGRAMS

10.2 COMMUNICATION

10.2.1 COMMUNICATION K-LINES

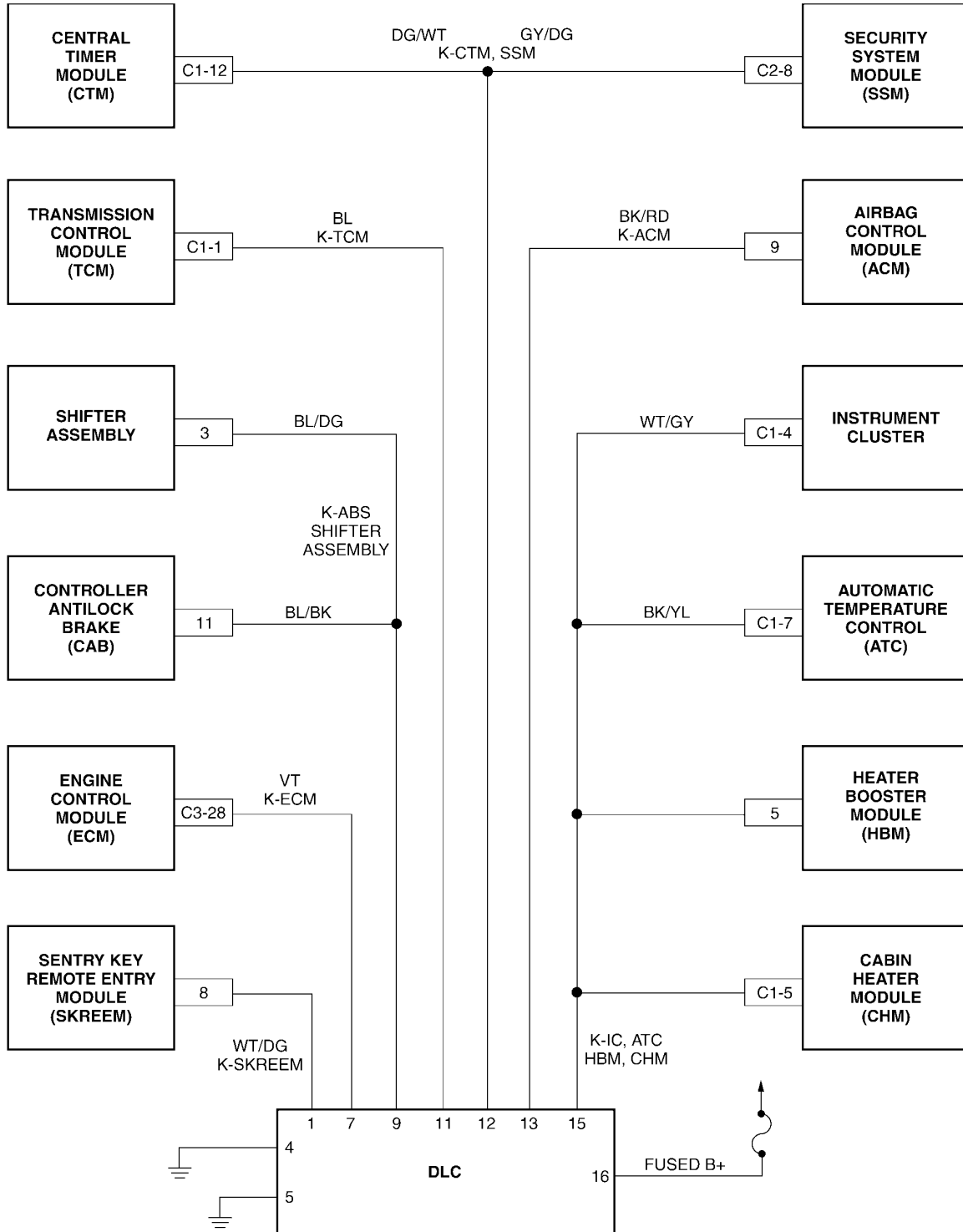

SCHEMATIC DIAGRAMS

10.2.2 CAN BUS NETWORK

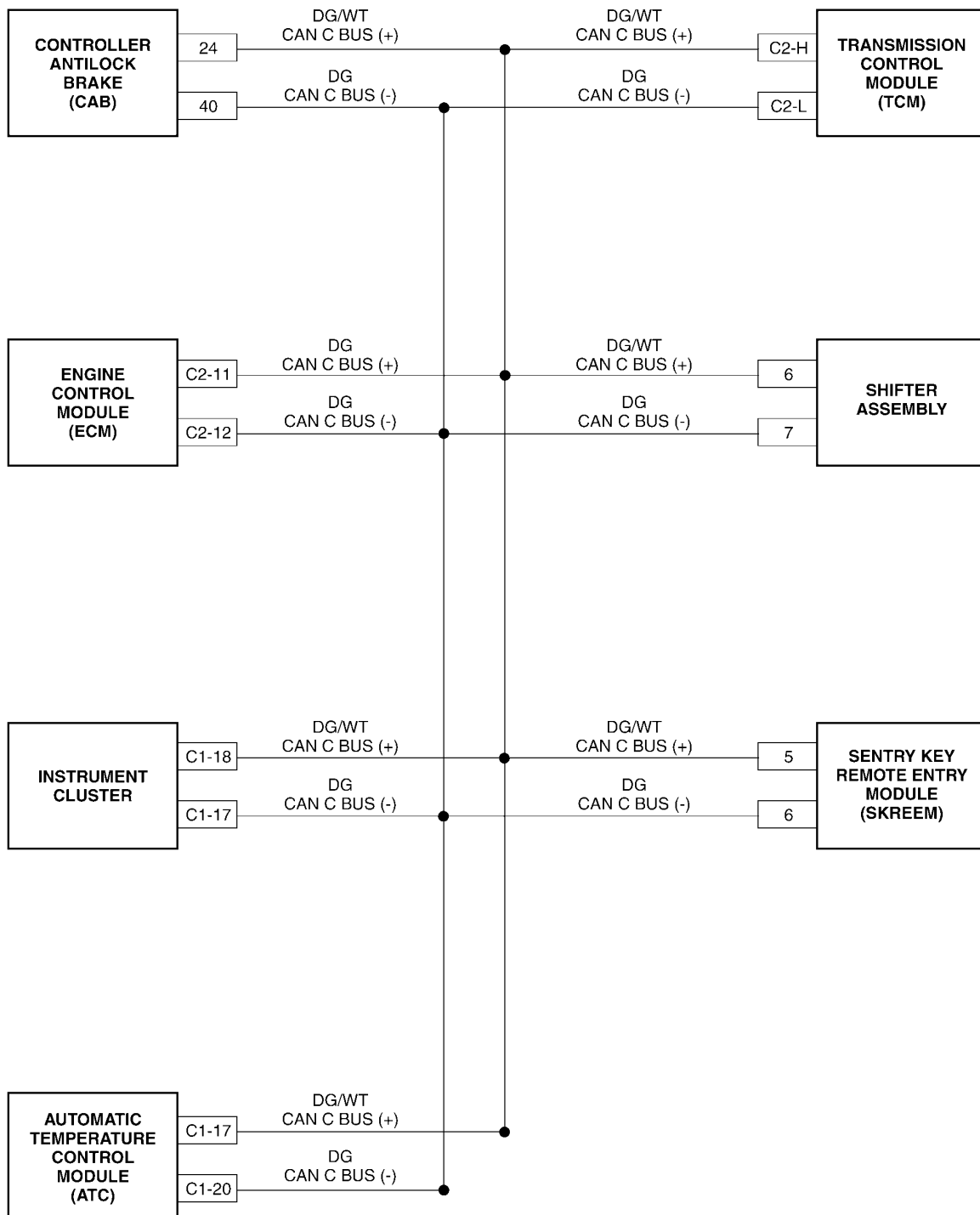

8110cfea

SCHEMATIC DIAGRAMS

10.3 HEATING & A/C

10.3.1 AUTOMATIC TEMPERATURE CONTROL (ATC)

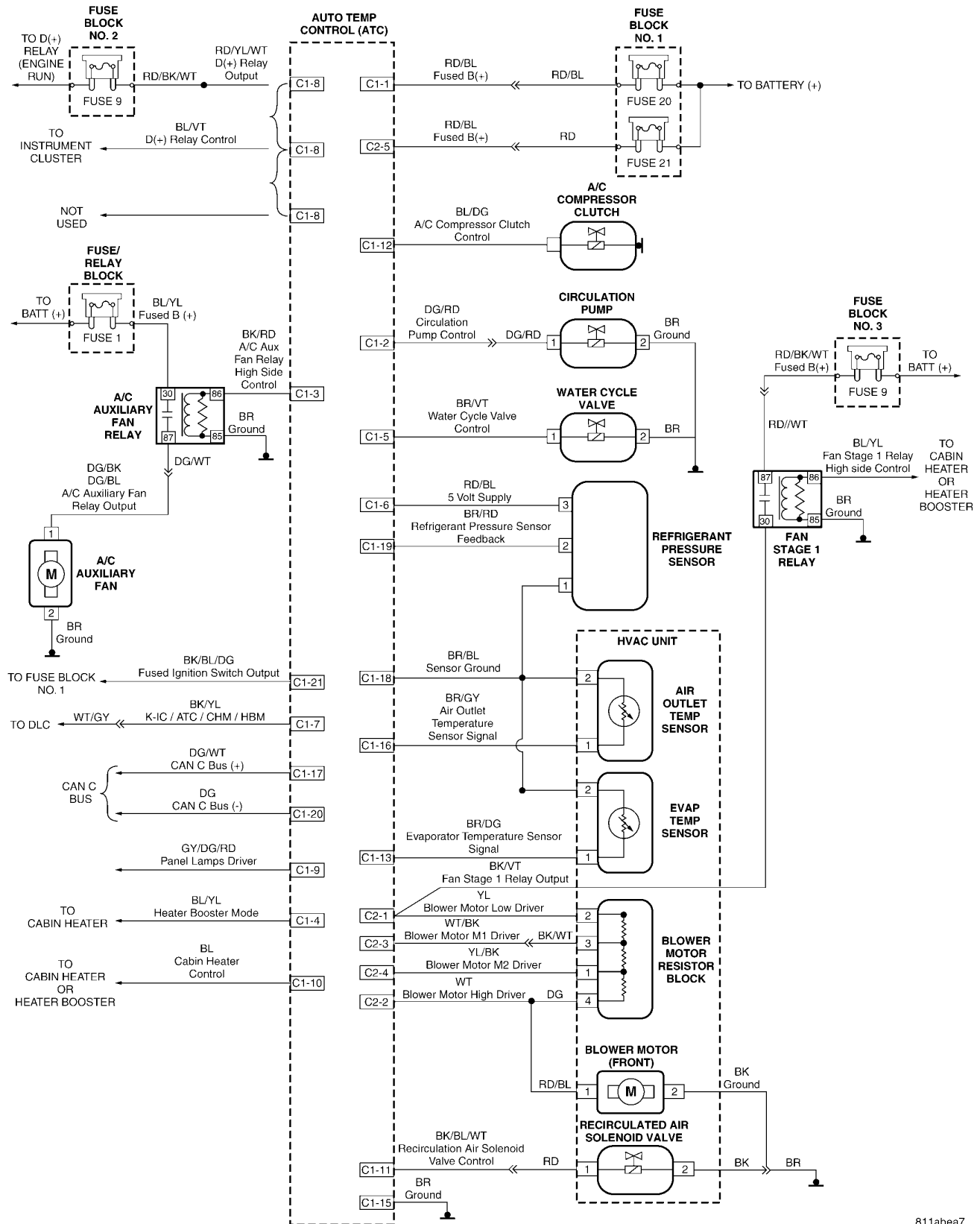

SCHEMATIC DIAGRAMS

10.3.2 CABIN HEATER MODULE (CHM)

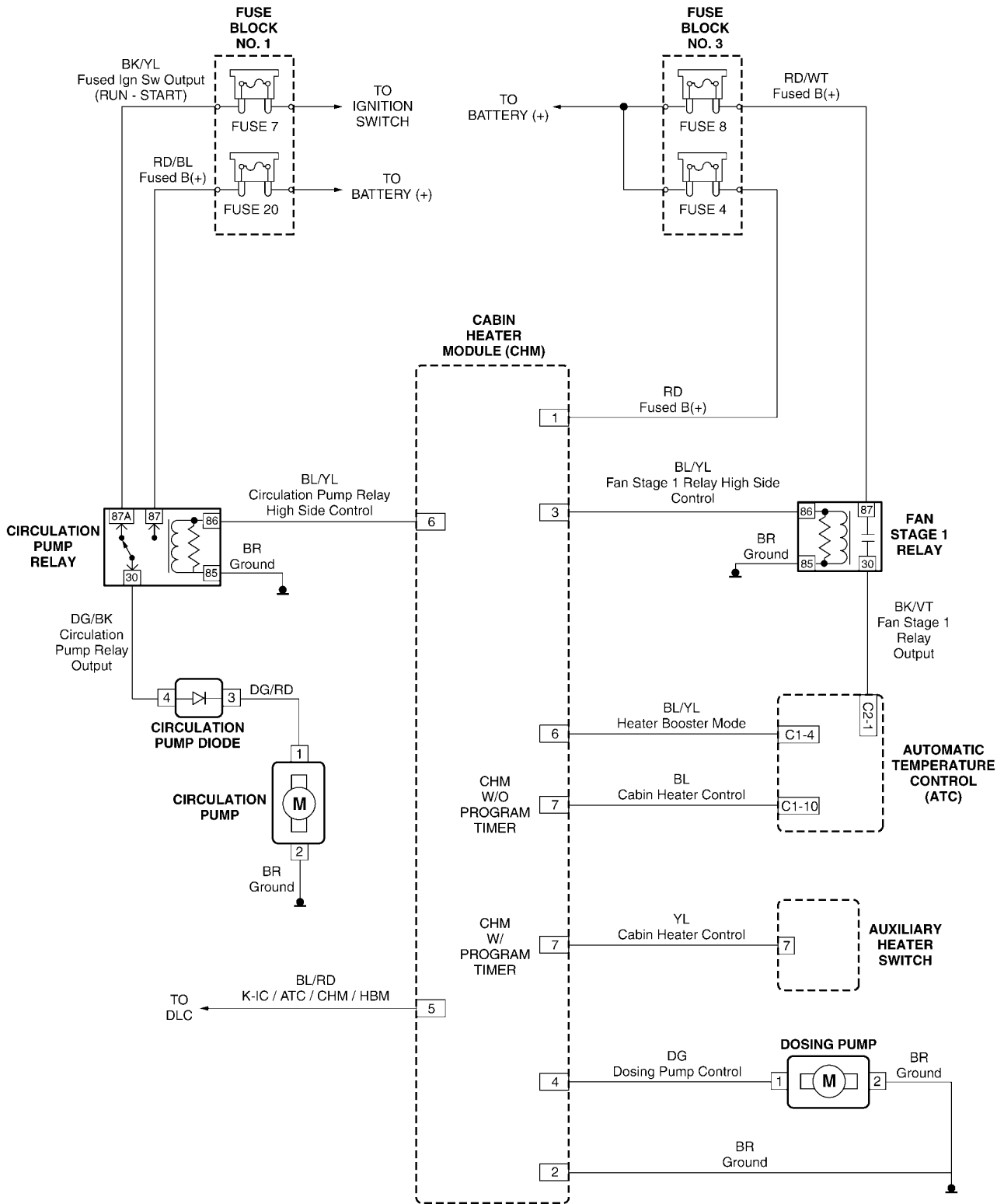

811abec5

SCHEMATIC DIAGRAMS

SCHEMATIC DIAGRAMS

10.3 HEATING & A/C (Continued)

10.3.3 HEATER BOOSTER MODULE (HBM)

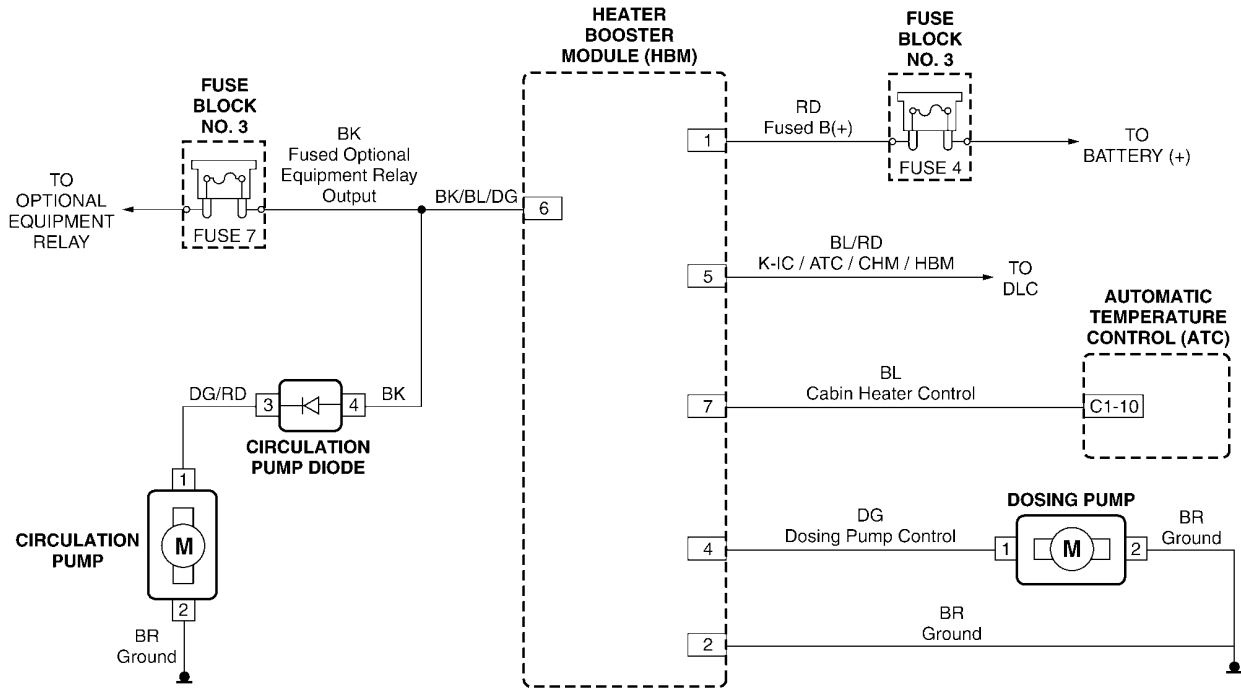

81125108

SCHEMATIC DIAGRAMS

10.4 INSTRUMENT CLUSTER

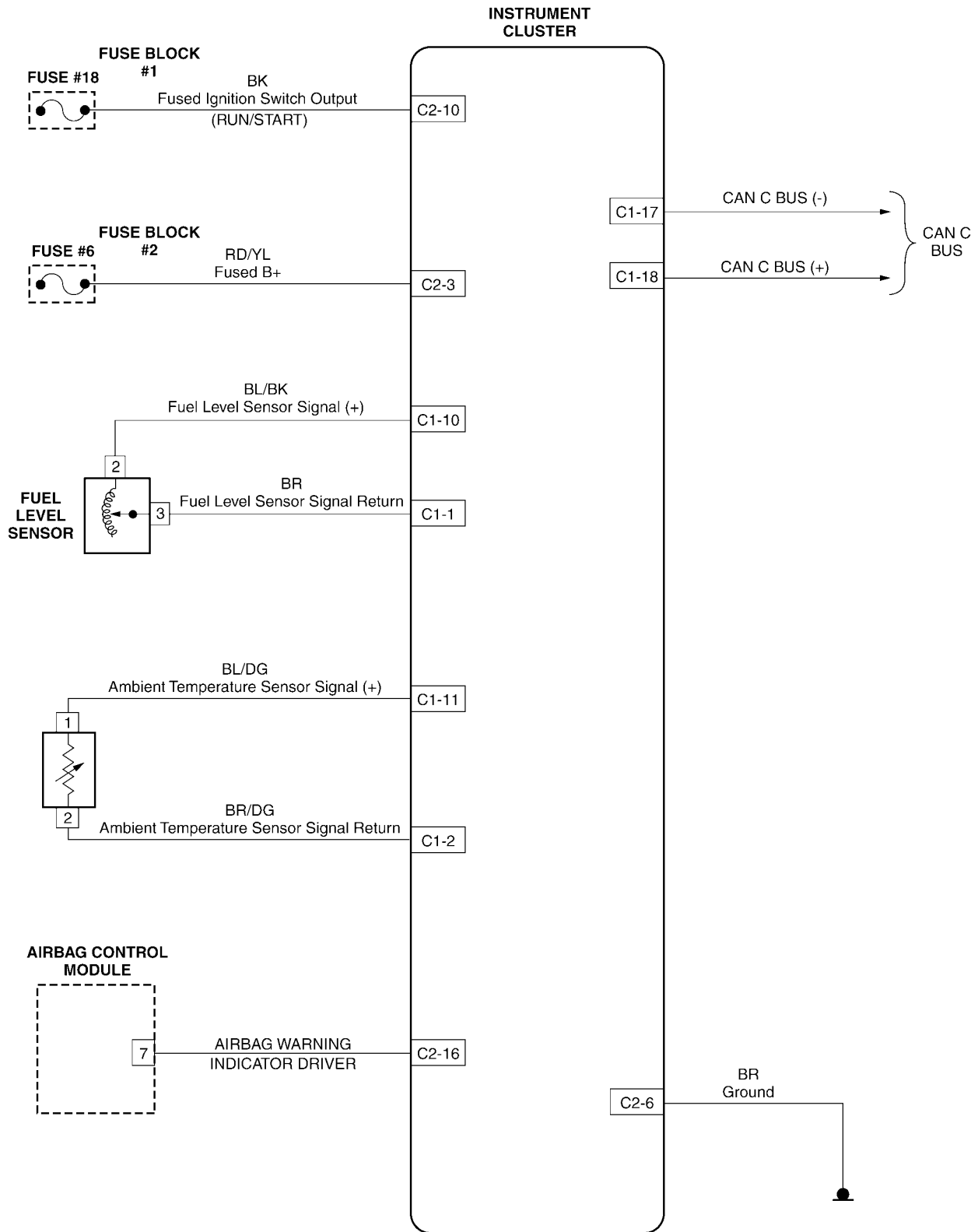

811b0899

SCHEMATIC DIAGRAMS

10.5 POWER DOOR LOCKS/RKE

10.5.1 FRONT DOORS

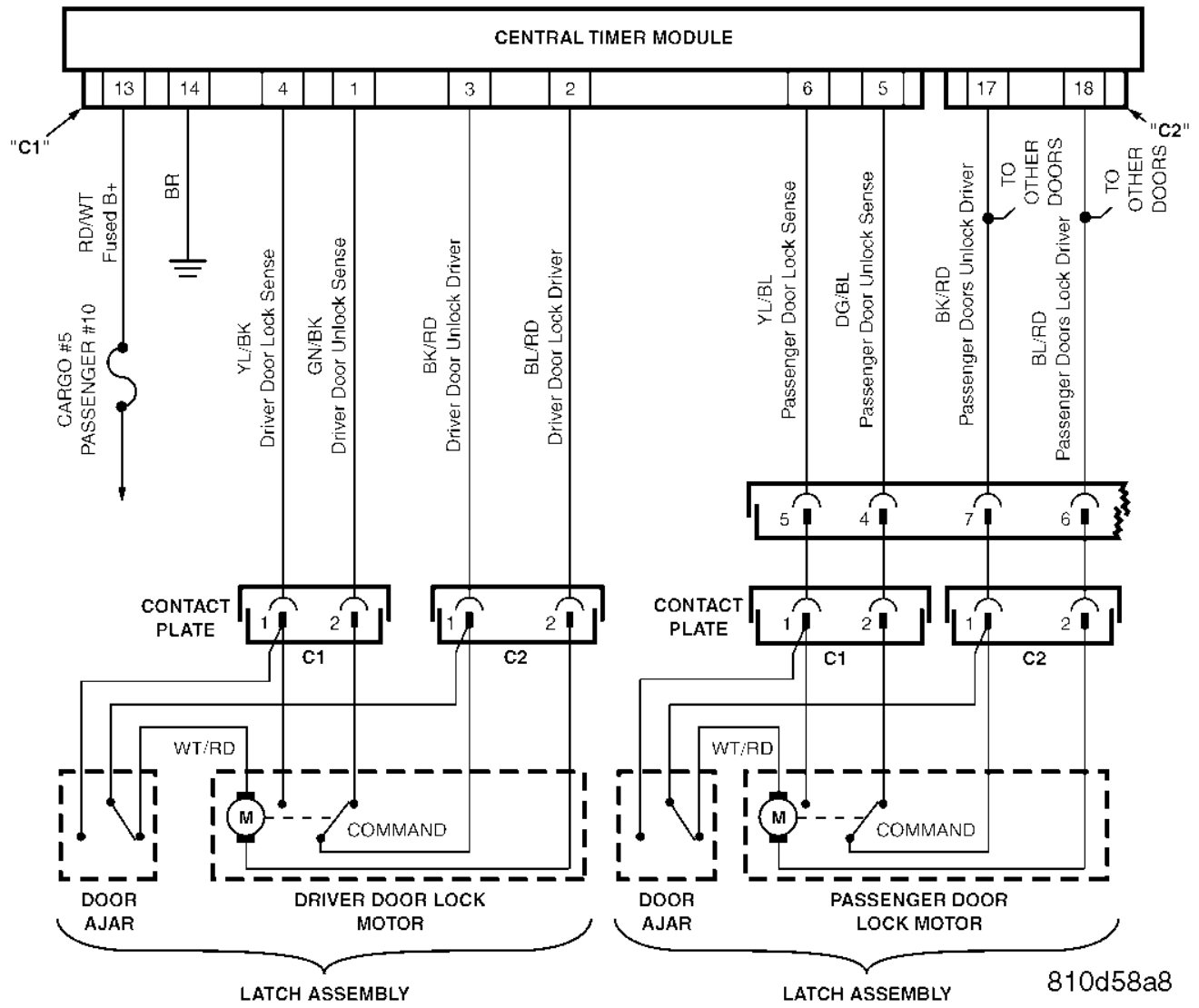

SCHEMATIC DIAGRAMS

10.5.2 SLIDING AND REAR DOORS

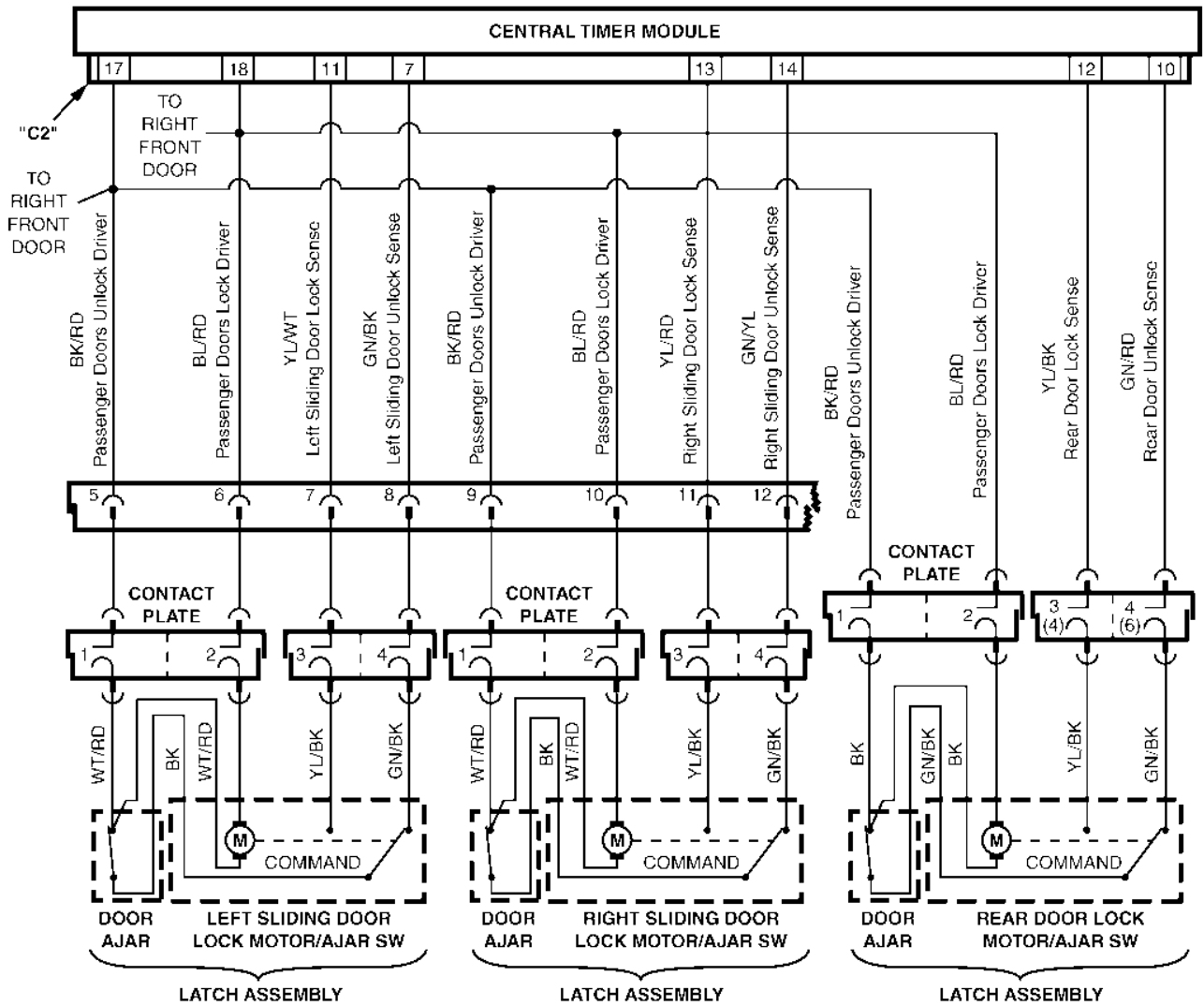

810df5c4

SCHEMATIC DIAGRAMS

10.5 POWER DOOR LOCKS/RKE (Continued)

10.5.3 SWITCH AND MISCELLANEOUS CIRCUITS

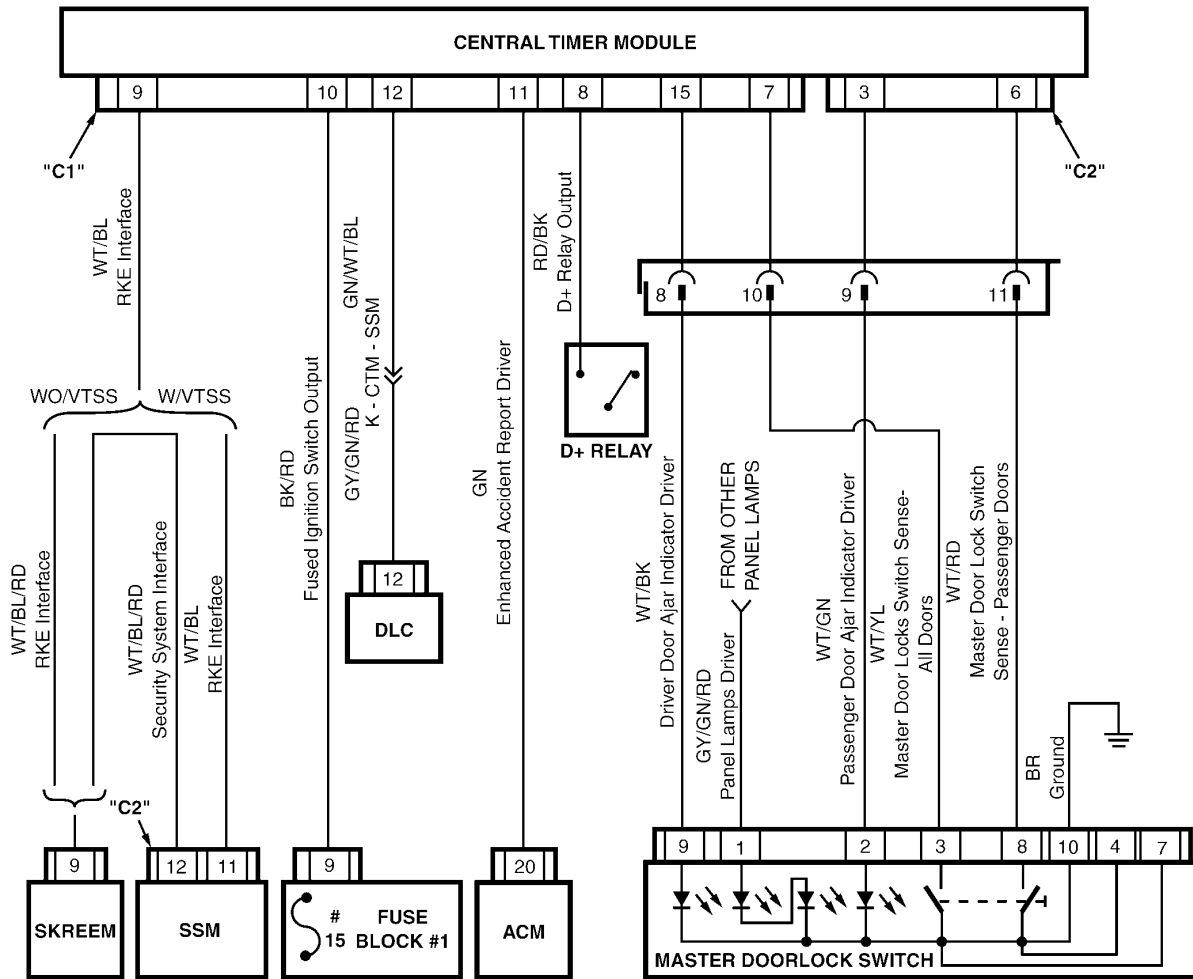

810ea353

SCHEMATIC DIAGRAMS

10.6 VEHICLE THEFT SECURITY SYSTEM

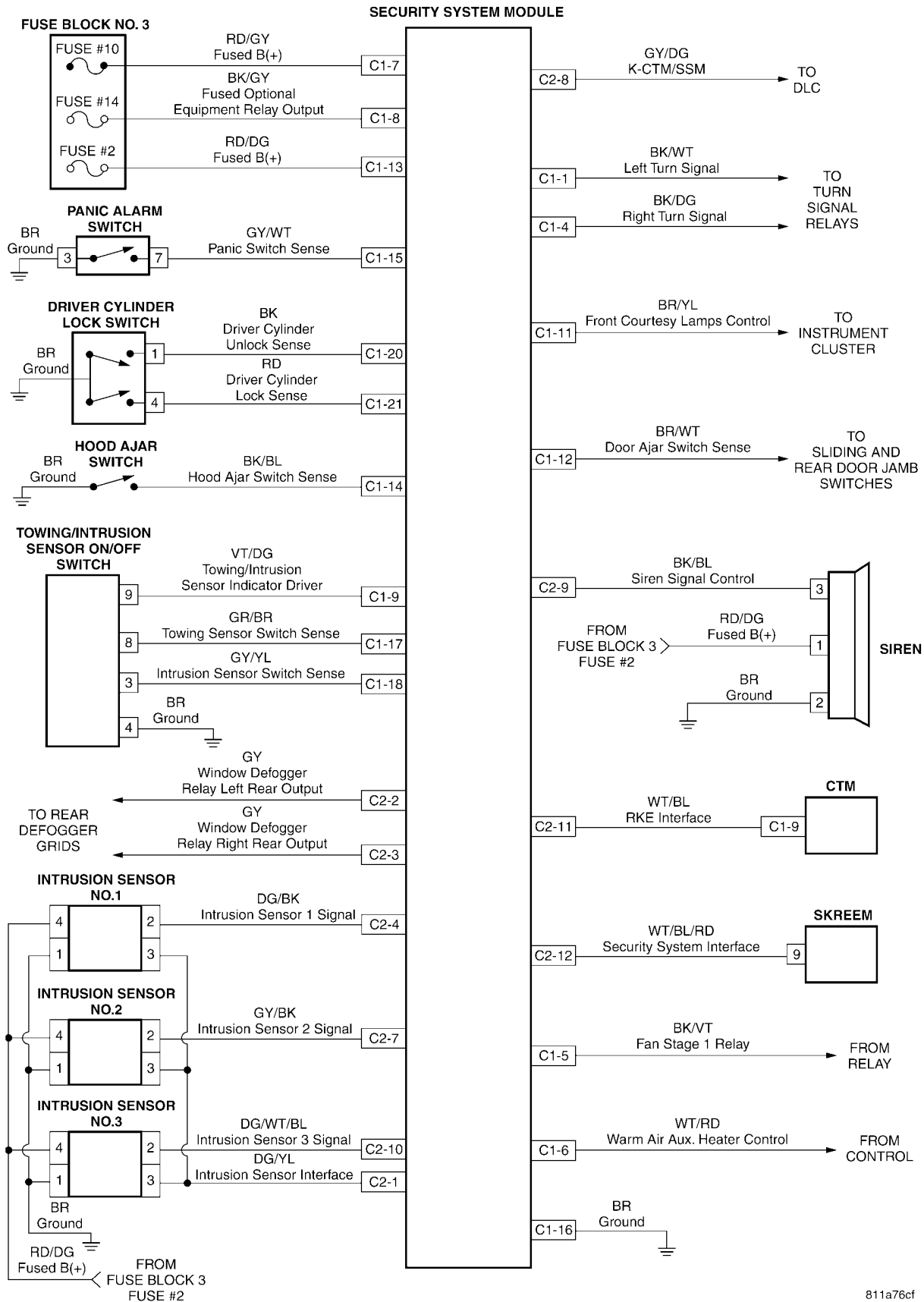

SCHEMATIC DIAGRAMS

811a76cf

11.0 CHARTS AND GRAPHS

11.1 EVAP TEMP SENSOR RESISTANCE TO TEMPERATURE SPECIFICATIONS

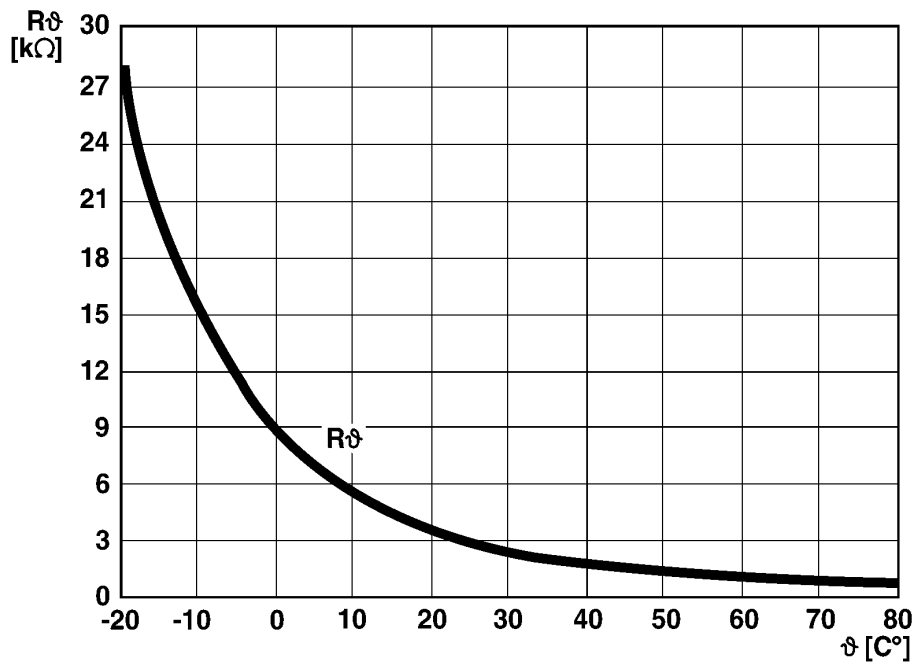

8111517e

11.2 AIR OUTLET TEMP SENSOR RESISTANCE TO TEMPERATURE SPECIFICATIONS

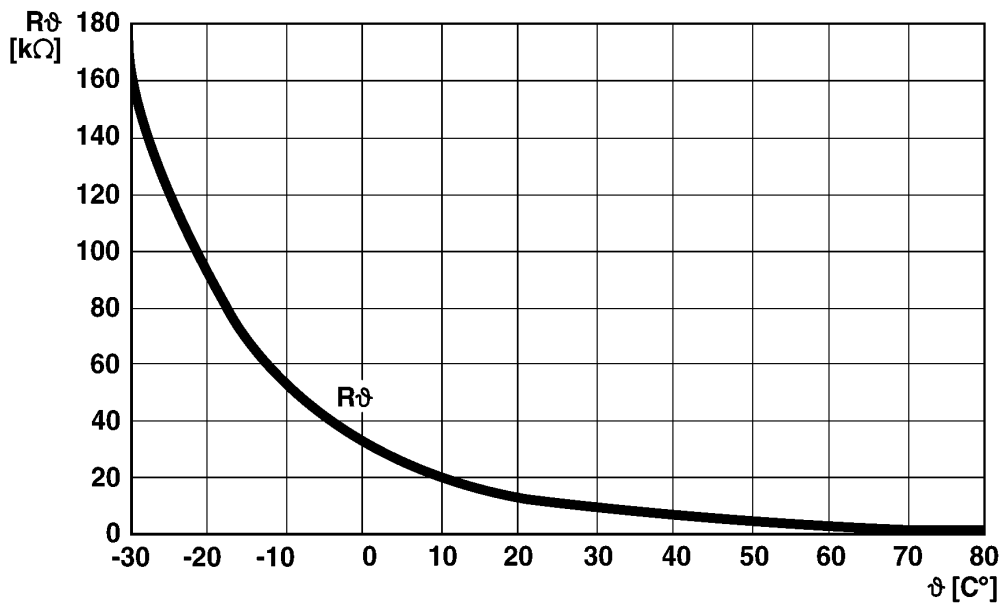

81115183

DIAGNOSTIC TEST PROCEDURES — TELL US!

DaimlerChrysler Corporation is constantly working to provide the technician the best diagnostic manuals possible. Your comments and recommendations regarding the diagnostic manuals and procedures are appreciated.

To best understand your suggestion, please complete the form giving us as much detail as possible.

Model _____ **Year** _____ **Body Type** _____ **Engine** _____

Transmission _____ **Vehicle Mileage** _____ **MDH** _____

Diagnostic Procedure _____ **Book No.** _____ **Page** _____

Comments/recommendations (if necessary, draw sketch)

Name _____

Submitted by: _____

Address _____

City/State/Zip _____

Business Phone # _____

All comments become property of DaimlerChrysler Corporation and may be used without compensation.

(FOLD HERE)

BUSINESS REPLY MAIL

FIRST CLASS MAIL PERMIT NO. 124 CENTER LINE, MI

POSTAGE WILL BE PAID BY ADDRESSEE

DaimlerChrysler Corporation
Dealer Technical Operations
800 Chrysler Drive
CIMS 486-02-76
Auburn Hills, MI 48326-2757

NO POSTAGE
NECESSARY
IF MAILED
IN THE
UNITED
STATES



(FOLD HERE)